

Installation

S19-220BSS

Stainless Steel Wall-Mounted Eyewash

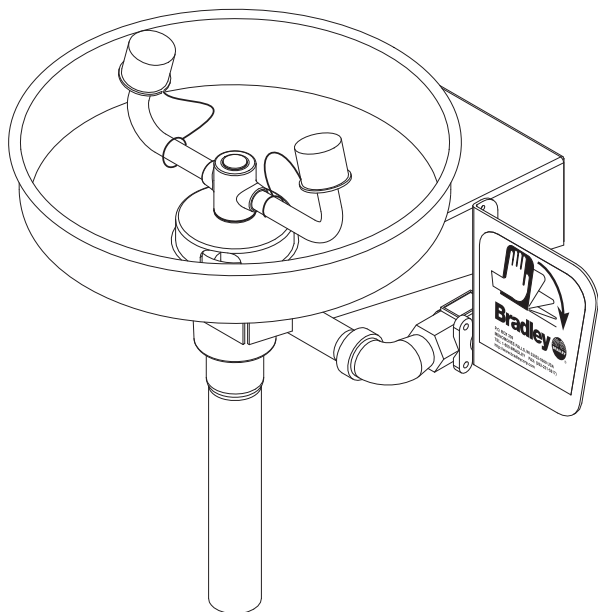
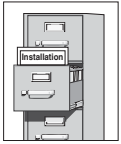

Table of Contents

Pre-Installation Information	2
Installation Instructions	3
Assembly of Components	4
Parts List	4



WARNING



Read this installation manual completely to ensure proper installation, then file it with the owner or maintenance department. Compliance and conformity to drain requirements and other local codes and ordinances is the responsibility of the installer.



Separate parts from packaging and make sure all parts are accounted for before discarding any packaging material. If any parts are missing, do not begin installation until you obtain the missing parts.

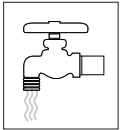

Flush the water supply lines before beginning installation and after installation is complete. Test the unit for leaks and adequate water flow. Main water supply to the eyewash should be "ON" at all times. Provisions shall be made to prevent unauthorized shutoff.



The ANSI Z358.1 standard requires an uninterrupted supply of flushing fluid at a minimum 30 PSI (0.21 MPa) flowing pressure. Flushing fluid should be tepid per ANSI Z358.1.

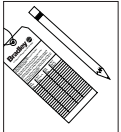

The inspection and testing results of this equipment should be recorded weekly to verify proper operation. This equipment should be inspected annually to ensure compliance with ANSI Z358.1.



Workers who may come in contact with potentially hazardous materials should be trained regarding the placement and proper operation of emergency equipment per ANSI Z358.1.



For questions regarding the operation or installation of this product, visit www.bradleycorp.com or call 1-800-BRADLEY.

Product warranties may also be found under "Product Information" on our web site at www.bradleycorp.com.

Installation

Supplies Required:

- (3) 3/8" wall fasteners and bolts
- Pipe sealant
- Piping to 1/2" NPT water supply inlet on unit
- Piping to 1-1/4" NPT drain outlet for eyewash
- Sign-mounting hardware

NOTE: Local codes may require the installation of a backflow prevention valve to complete proper installation. Compliance with local codes is the responsibility of the installer. Valve must be tested annually to verify that it is functioning properly. Backflow prevention valves are not included with the fixture and may be supplied by the contractor or purchased from Bradley Corporation.

Step 1: Install inlet drain fitting

NOTE: The top of the eyewash heads should be 33"–45" (838mm–1143mm) from the floor.

1. Position the inlet drain fitting over the 1-1/4" drain outlet pipe from wall.
2. Using the inlet drain fitting as a template, mark the bolt hole locations on wall OR install three suitable fasteners (supplied by installer) for 3/8" bolts in the wall at the marked hole locations.
3. Bolt the inlet drain fitting to the wall or wall fasteners using 3/8" bolts (supplied by installer).

Step 2: Assemble components

1. Assemble the remaining eyewash components as shown on page 4.
 - Apply pipe sealant (supplied by installer) to all male-threaded pipe joints.
 - Use a strap wrench around pipes when tightening to prevent pipe marring.

Step 3: Connect water supply

1. Connect the water supply piping to the 1/2" NPT inlet on the eyewash (piping supplied by installer).
2. Connect the tailpiece to the 1-1/4" NPT drain outlet on the eyewash.
3. Mount the safety sign to the wall using sign-mounting hardware (supplied by installer).
4. Open the water supply lines. Test for leaks and adequate water flow.

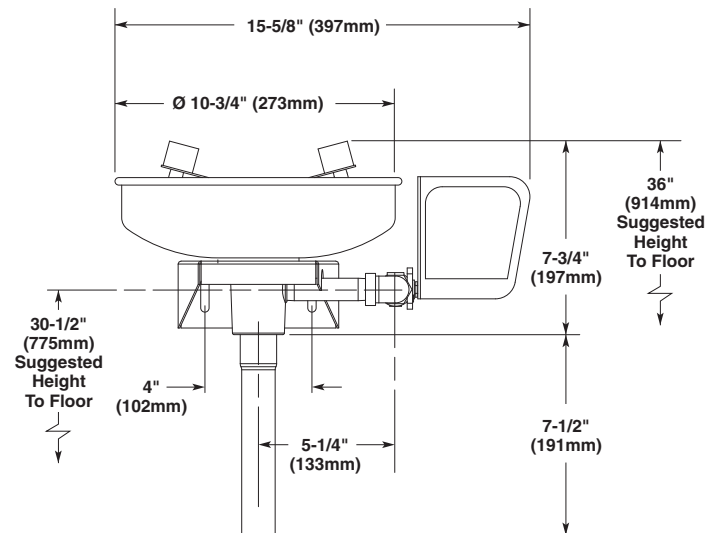
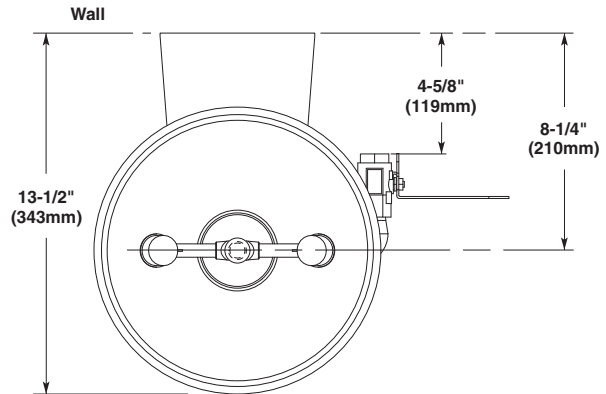

NOTE: All dimensions assume standard thread engagement. Variations in manufacturing allow for +/- 1/8 (3mm) per threaded joint. To find the tolerance of a dimension, add the number of thread joints in between a dimension and multiply it by 1/8 (3mm).

Assembly of Components and Parts List

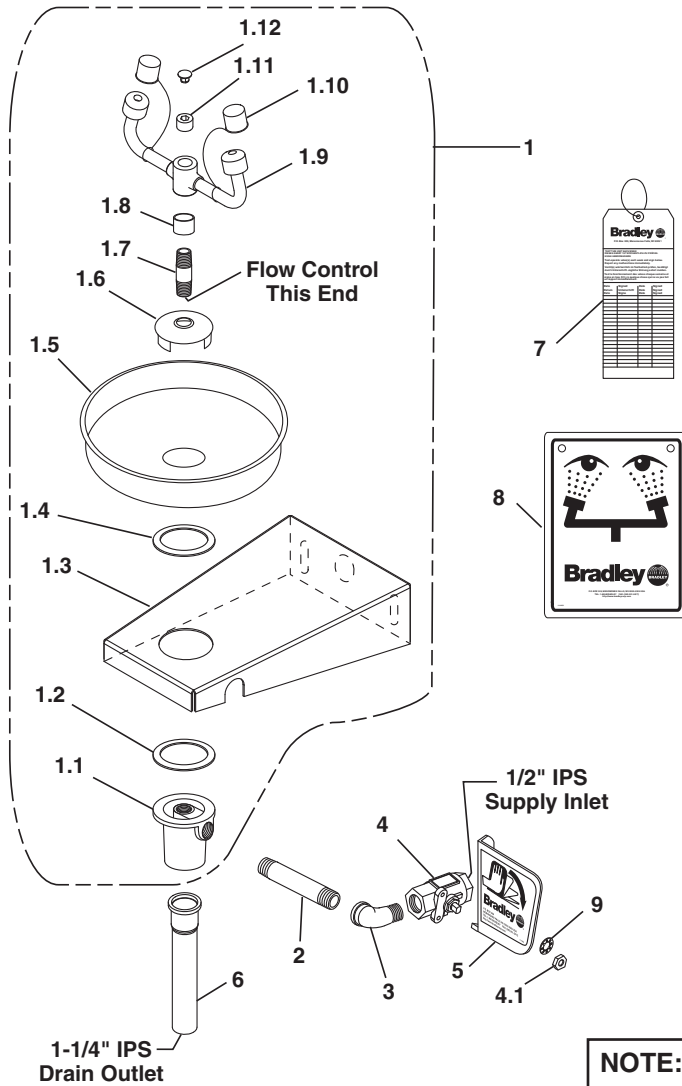

NOTE: Items 1.1-1.12 come preassembled as Item 1.

Item	Part No.	Qty	Description	Item	Part No.	Qty	Description
1	S90-359	1	Stainless Steel Eyewash	1.11	153-333	1	Pipe Plug
1.1	111-049	1	Inlet Drain Fitting	1.12	269-874	1	Cap Plug
1.2	124-028	1	Gasket	2	113-965	1	Pipe, Stainless Steel 1/2 x 3-1/2
1.3	140-645	1	Wall Bracket	3	269-241	1	Elbow
1.4	124-024	1	Gasket	4	S27-287	1	1/2 Ball Valve with Nut
1.5	187-053	1	Stainless Steel Eyewash Bowl	4.1	110-215	1	Nut only
1.6	173-009	1	Cup Strainer	5	S08-338	1	Handle Assembly
1.7	S21-072	1	Supply Stem	6	269-167	1	Tailpiece
1.8	113-1159	1	Spacer, Drain	7	114-051	1	Safety Sign
1.9	S05-131	1	Eyewash Yoke Assembly	8	204-421	1	Emergency Tag
1.10	107-371	2	Dust Cover	9	142-002DA	1	Washer

Prepack S45-1787 includes Items 1.4, 1.6, 1.7, 1.8