

Installation

S19-210DCR

Pedestal-Mounted Eyewash with Dust Cover

Table of Contents

Pre-Installation Information	2
Installation Instructions	3
Assembly of Components	4
Parts List	5

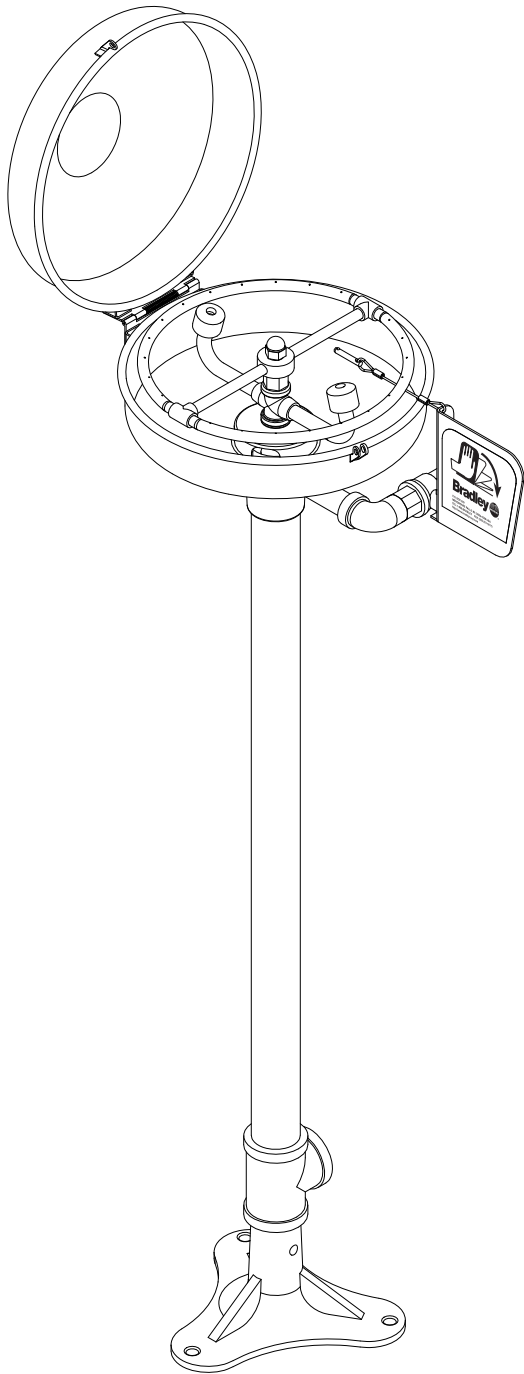

⚠ WARNING ⚠

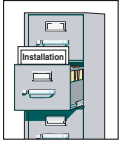

Read this installation manual completely to ensure proper installation, then file it with the owner or maintenance department. Compliance and conformity to drain requirements and other local codes and ordinances is the responsibility of the installer.



Separate parts from packaging and make sure all parts are accounted for before discarding any packaging material. If any parts are missing, do not begin installation until you obtain the missing parts.

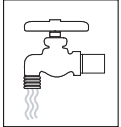

Flush the water supply lines before beginning installation and after installation is complete. Test the unit for leaks and adequate water flow. Main water supply to the eyewash should be "ON" at all times. Provisions shall be made to prevent unauthorized shutoff.

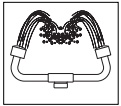

The ANSI Z358.1 standard requires an uninterrupted supply of flushing fluid at a minimum 30 PSI (0.21 MPa) flowing pressure. Flushing fluid should be tepid per ANSI Z358.1.



The inspection and testing results of this equipment should be recorded weekly to verify proper operation. This equipment should be inspected annually to ensure compliance with ANSI Z358.1.



Workers who may come in contact with potentially hazardous materials should be trained regarding the placement and proper operation of emergency equipment per ANSI Z358.1.



For questions regarding the operation or installation of this product, visit www.bradleycorp.com or call 1-800-BRADLEY.

Product warranties may also be found under "Product Information" on our web site at www.bradleycorp.com.

Installation

NOTE: Flush the water supply line before beginning installation.

Supplies Required:

- (3) 3/8" floor anchors and bolts
- Pipe sealant
- Piping to 1/2" IPS water supply inlet on unit
- Piping to 1-1/4" IPS drain outlet for eyewash
- Sign-mounting hardware

Step 1: Secure base to floor

1. To secure base to floor, install three suitable anchors (supplied by installer) for 3/8" bolts in the floor (Figure 1).
2. Bolt the base to the floor anchors using 3/8" bolts (supplied by installer).

Step 2: Assemble eye wash components

1. Assemble eyewash components as shown in Figure 2 on page 4.
 - Apply pipe sealant (supplied by installer) to all male-threaded pipe joints.
 - Use the rubber grip pad provided or a strap wrench around pipes when tightening to prevent marring. Place the grip pad on the pipe, then put the wrench over the grip pad and turn the pipe with the wrench.

Step 3: Connect water supply

1. Connect the water supply piping (supplied by installer) to the 1/2" IPS inlet on the eyewash.
2. Connect the drain piping (supplied by installer) to the 1-1/4" IPS drain outlet on the eyewash.
3. Mount the safety sign to the wall using sign-mounting hardware (supplied by installer).
4. Open the water supply lines. Test for leaks and adequate water flow.

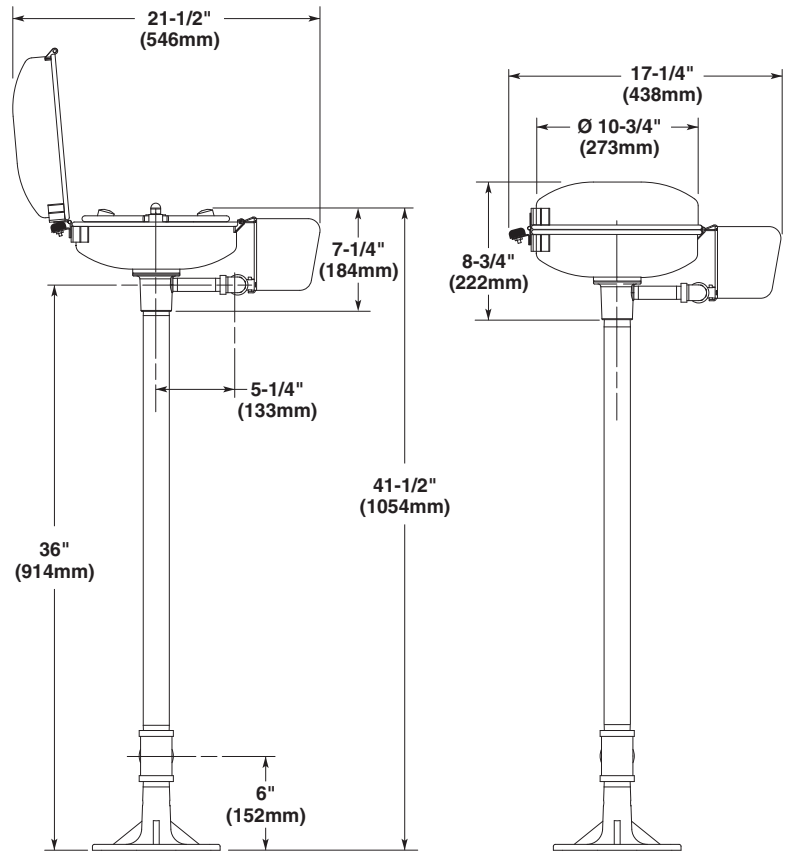

NOTE: All dimensions assume standard thread engagement. Variations in manufacturing allow for +/- 1/8" (3mm) per threaded joint. To find the tolerance of a dimension, add the number of thread joints in between a dimension and multiply it by 1/8" (3mm).

Figure 1

Assembly of Components

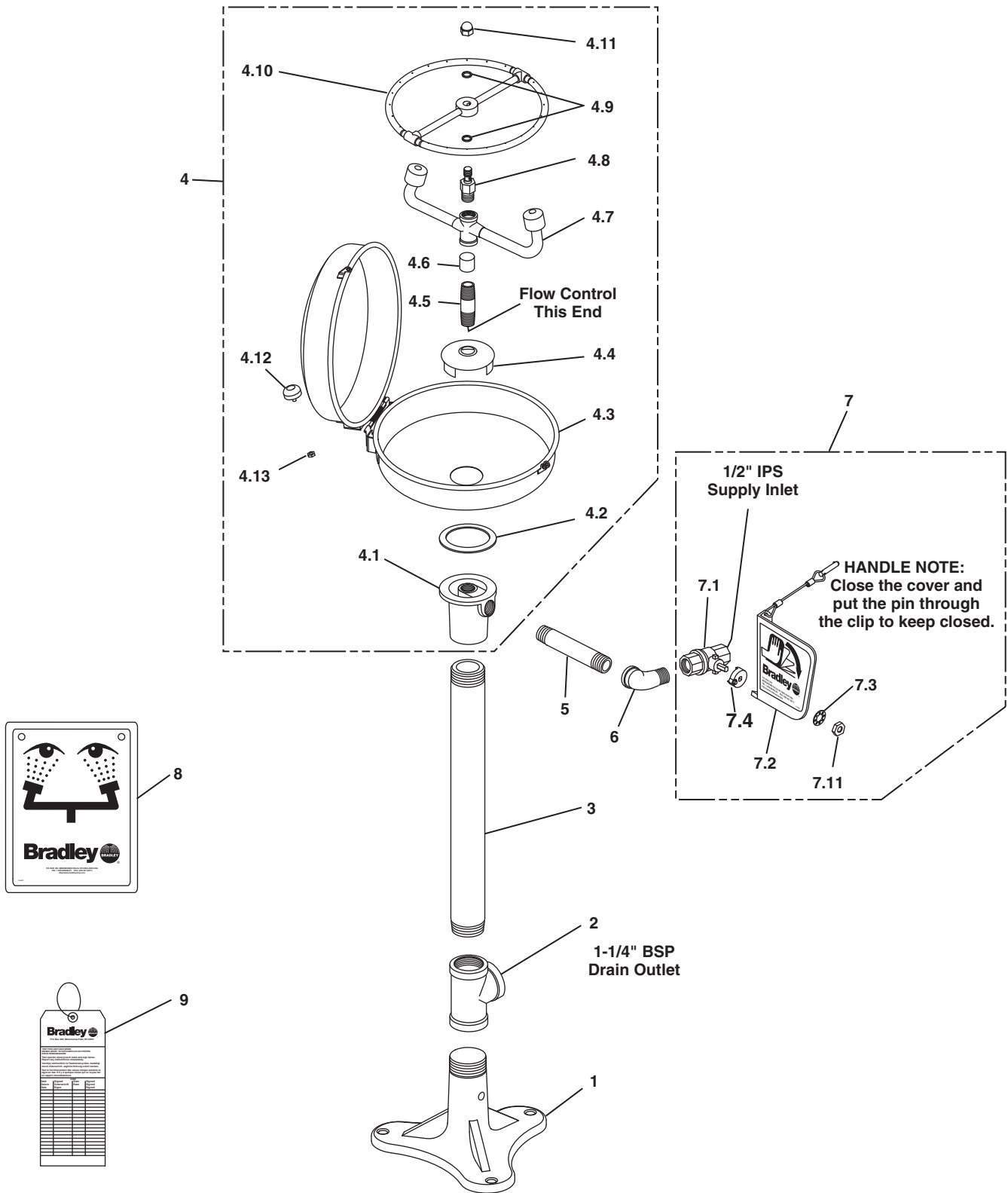

Figure 2

NOTE: Items 4.1–4.13 come preassembled as Item 4.

Parts List

Item	Part No.	Qty	Description	Item	Part No.	Qty	Description
1	131-059	1	Base	4.11	110-199	1	Acorn Nut
2	169-727	1	Pipe Tee, 1-1/4" IPS	4.12	269-447	1	Bumper
3	113-006LC	1	Pipe, 1-1/4" x 27-1/2"	4.13	161-025	1	Hex Nut
4	S90-292	1	Dust Cover w/Spray Ring	5	113-006LQ	1	Pipe 1/2" IPS x 3-1/2"
4.1	111-039	1	Inlet-Drain Fitting	6	169-025	1	Elbow
4.2	124-028	1	Gasket	7	S30-072	1	1/2" Valve/Handle Prepack
4.3	S90-009	1	Dust Cover Assembly	7.1	S27-282	1	1/2" Ball Valve with Nut
4.4	173-009	1	Cup Strainer	7.11	110-215	1	Nut only
4.5	S21-073	1	Supply Pipe Assembly	7.2	S08-056	1	Handle Assembly
4.6	113-1159	1	Spacer, Drain	7.3	142-002DA	1	Lockwasher
4.7	S05-100	1	Eyewash Yoke Assembly	7.4	153-372R	1	Adapter
4.8	269-651	1	Swivel Stem	8	114-051	1	Safety Sign
4.9	124-055	2	Quad Ring	9	204-421	1	Emergency Tag
4.10	139-087	1	Spray Ring Assembly	10	269-915	1	Grip Pad (not shown)

Prepack S30-087 includes Items 7.11, 7.2, 7.3, 7.4

Prepack S05-127 includes Items 4.8, 4.9, 4.10, 4.11