

Installation

S19-220BF

Wall-Mounted Eyewash

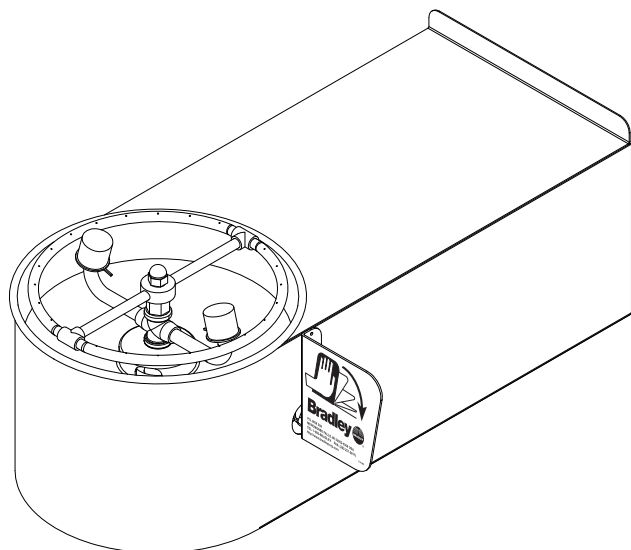

Table of Contents

Pre-Installation Information	2
Installation Instructions	3
Assembly of Components	4
Parts List	5



WARNING



Read this installation manual completely to ensure proper installation, then file it with the owner or maintenance department. Compliance and conformity to drain requirements and other local codes and ordinances is the responsibility of the installer.



Separate parts from packaging and make sure all parts are accounted for before discarding any packaging material. If any parts are missing, do not begin installation until you obtain the missing parts.

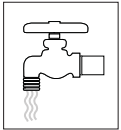

Flush the water supply lines before beginning installation and after installation is complete. Test the unit for leaks and adequate water flow. Main water supply to the eyewash should be "ON" at all times. Provisions shall be made to prevent unauthorized shutoff.



The ANSI Z358.1 standard requires an uninterrupted supply of flushing fluid at a minimum 30 PSI (0.21 MPa) flowing pressure. Flushing fluid should be tepid per ANSI Z358.1.

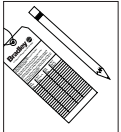

The inspection and testing results of this equipment should be recorded weekly to verify proper operation. This equipment should be inspected annually to ensure compliance with ANSI Z358.1.



Workers who may come in contact with potentially hazardous materials should be trained regarding the placement and proper operation of emergency equipment per ANSI Z358.1.



For questions regarding the operation or installation of this product, visit www.bradleycorp.com or call 1-800-BRADLEY.

Product warranties and service parts information may also be found under "Products" on our web site at www.bradleycorp.com.

Installation

Supplies Required:

- (4) 5/16" wall anchors and bolts
- Pipe sealant
- Piping to 1/2" NPT water supply inlet
- Piping to 1-1/4" drain outlet
- Sign-mounting hardware

NOTE: Local codes may require the installation of a backflow prevention valve to complete proper installation. Compliance with local codes is the responsibility of the installer. Valve must be tested annually to verify that it is functioning properly. Backflow prevention valves are not included with the fixture and may be supplied by the contractor or purchased from Bradley Corporation.

Step 1: Install inlet drain fitting

1. Rough-in supply piping and drain piping at the dimensions shown. Mark the bracket and mounting hole locations on the wall. Install suitable wall anchors (supplied by installer) at the bracket and mounting hole locations.
2. Secure support brackets to the wall with 5/16" bolts (supplied by installer).
3. Position the eyewash with skirt over the support brackets and rest the back of the skirt on the brackets.
4. Fasten the skirt to the wall with 5/16" bolts (supplied by installer) at the mounting hole locations.

Step 2: Assemble components

1. Assemble eyewash components as shown on page 4.
 - Apply pipe sealant (supplied by installer) to all male-threaded pipe joints.
 - Use a strap wrench around pipes when tightening to prevent marring.

Step 3: Connect water supply

1. Connect the water supply piping (supplied by installer) to the 1/2" NPT inlet on the eyewash.
2. Connect the tailpiece to the 1-1/4" drain outlet on the eyewash.
3. Mount the safety sign to the wall using sign-mounting hardware (supplied by installer).
4. Open the water supply lines. Test for leaks and adequate water flow.

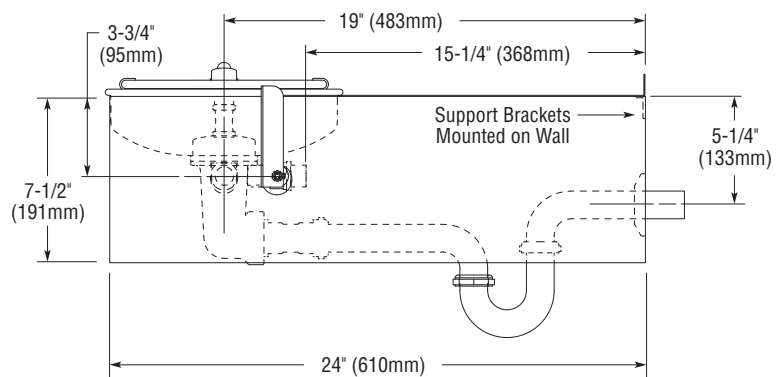
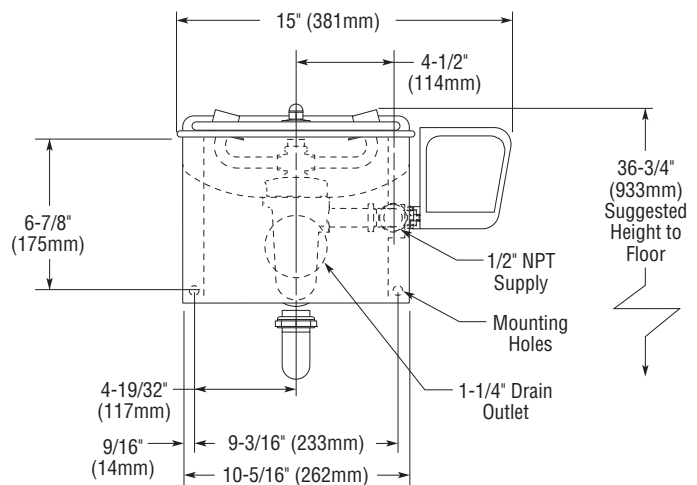
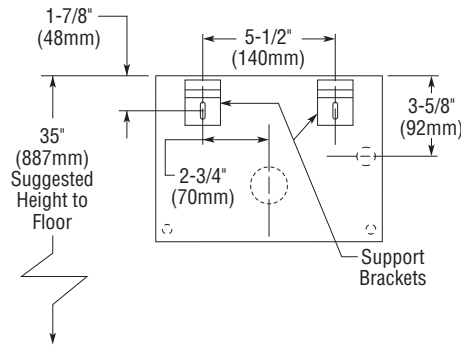

Parts List

Item	Part No.	Qty	Description	Item	Part No.	Qty	Description
1	S90-290	1	Spray Ring Assy.	3	169-1024	1	Coupling
1.1	111-084A	1	Inlet-Drain Fitting w/Elbow	4	111-087	1	P-trap/Wall Tube
1.2	124-028	1	Center Seal Gasket	5	113-751	1	Pipe, 1/2" x 2-1/2"
1.3	187-053	1	Eyewash Bowl	6	269-1100	1	Street Elbow
1.4	173-009	1	Cup Strainer	7	S27-282	2	1/2" Ball Valve with Nut
1.5	S21-073	1	Supply Pipe	7.1	110-215	1	Nut only
1.6	113-1159	1	Spacer, Drain	8	153-372R	1	Ball Valve Adapter (RH)
1.7	S05-100	1	Eyewash Yoke	9	S08-336	1	Handle Assy.
1.8	107-371	2	Dust Cover	10	142-002DA	1	Lockwasher
1.9	269-651	1	Swivel Stem	11	140-143	2	Support Bracket
1.10	124-055	2	Quad Ring	12	114-051	1	Safety Sign
1.11	139-087	1	Spray Ring	13	204-421	1	Emergency Inspection Tag
1.12	110-199	1	Acorn Nut	14	S30-070	1	Ball Valve Kit
2	S87-027	1	Cabinet Assy.				

Prepack S30-071 includes Items 7.1, 8, 9, 10

Prepack S05-127 includes Items 1.9, 1.10, 1.11, 1.12