

# Installation

## S19-435EFW

### Angled Hand-Held Drench Hose with Hose Holder

#### Table of Contents

Pre-Installation Information .....	2
Installation Instructions .....	3
Assembly of Components and Parts List .....	3-4

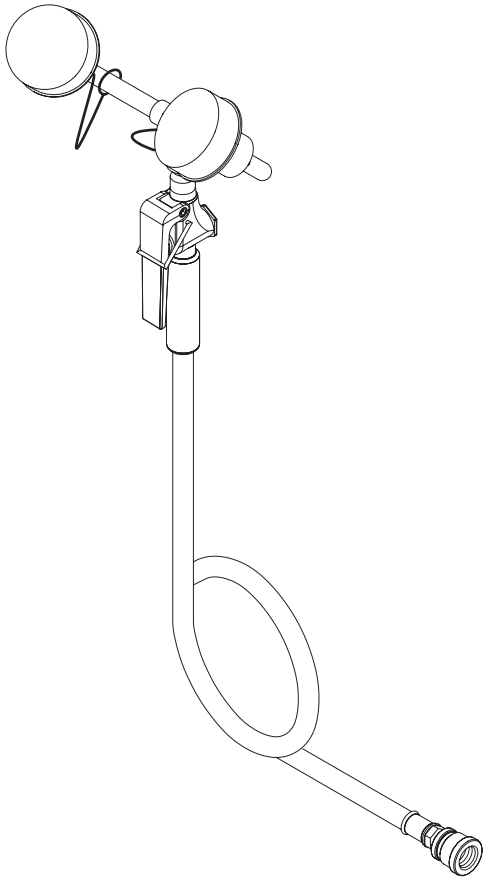

## Pre-Installation Information

### Operation

Water flows when the handle on the valve is squeezed and remains open while squeezed..

### Components

**Sprayhead:** Perforated sprayhead provides soft spray for cleansing eyes and face. The integral flow control assures safe, steady flow under varying water supply conditions from 30-90 PSI. *NOTE: The ANSI Z358.1 standard requires an uninterrupted supply of flushing fluid at a minimum 30 PSI flow pressure.*

**Drench Hose:** The 8' (2438 mm) hose has a 3/8" IPS male thread with a removable 1/2" x 3/8" female reducing coupling.

### Supplies Required:

- 1/2" IPS water supply
- #10 screw to mount hose clip (anchor optional)
- Backflow prevention device as required by UPC, IPC and/or local plumbing codes



## WARNING

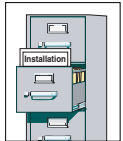

Read this installation manual completely to ensure proper installation, then file it with the owner or maintenance department. Compliance and conformity to drain requirements and other local codes and ordinances is the responsibility of the installer.



Separate parts from packaging and make sure all parts are accounted for before discarding any packaging material. If any parts are missing, do not begin installation until you obtain the missing parts.

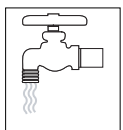

Flush the water supply lines before beginning installation and after installation is complete. Test the unit for leaks and adequate water flow. Main water supply to the eyewash should be "ON" at all times. Provisions shall be made to prevent unauthorized shutoff. Flushing fluid should be tepid per ANSI Z358.1.

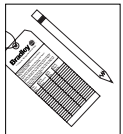

The inspection and testing results of this equipment should be recorded weekly to verify proper operation. This equipment should be inspected annually to ensure compliance with ANSI Z358.1.



Workers who may come in contact with potentially hazardous materials should be trained regarding the placement and proper operation of emergency equipment per ANSI Z358.1.



For questions regarding the operation or installation of this product, visit [www.bradleycorp.com](http://www.bradleycorp.com) or call 1-800-BRADLEY.

Product warranties may also be found under "Product Information" on our web site at [www.bradleycorp.com](http://www.bradleycorp.com).

# Installation Instructions

## Step 1: Mount hose

1. Rough-in 1/2" IPS supply piping from wall where hand-held drench hose is desired (piping supplied by installer).
2. Mount hose clip to wall with a #10 screw (supplied by installer). Install wall anchor if desired.

## Step 2: Connect water supply

1. Connect the end of the drench hose to the 1/2" IPS water supply.
2. Open the water supply line. Test for leaks and adequate water flow.

## Assembly of Components

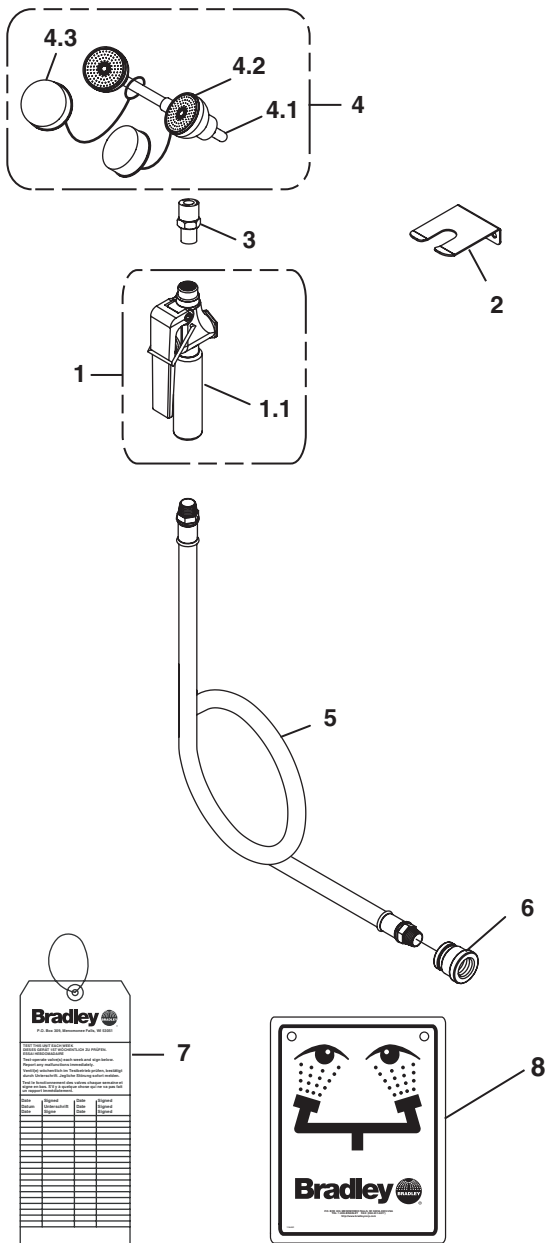

## Parts List

Item	Part No.	Qty	Description
1	S27-265	1	Valve Assembly
1.1	269-661	1	Handle only
2	S45-831	1	Clip Prepack
3	153-337	1	Adapter
4	S05-148	1	Angled EFW Assembly
4.1	S05-147	1	Angled Yoke Assembly
4.2	S05-135	2	Sprayhead
4.3	S53-063	2	Dust Cover
5	S89-002	1	3/8" Yellow Tube x 8'
6	169-059	1	Reducing Coupling 3/8" x 1/2"
7	204-421	1	Emergency Tag
8	114-051	1	Safety Sign

# Installation Instructions for Hose Holder

## PIPE MOUNTING

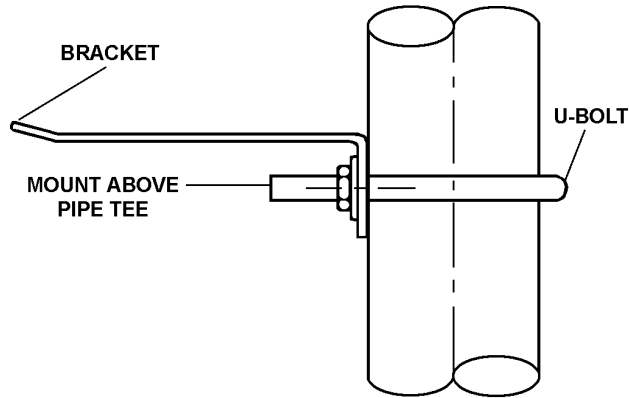

## WALL MOUNTING

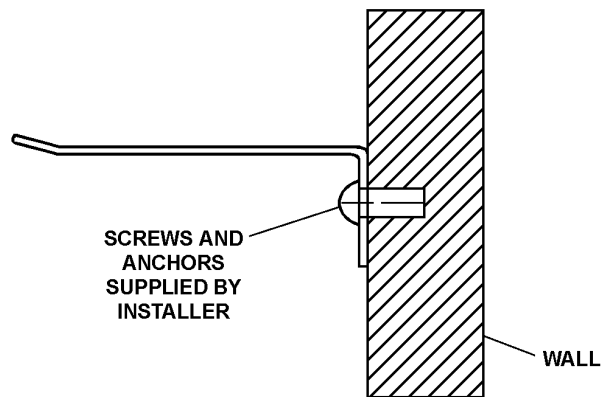

## PARTS LIST

	1-1/4" Pipe
Bracket	140-601
U-Bolt	269-681