

Installation

S19-465

Deck-Mounted Hand-Held Drench Hose

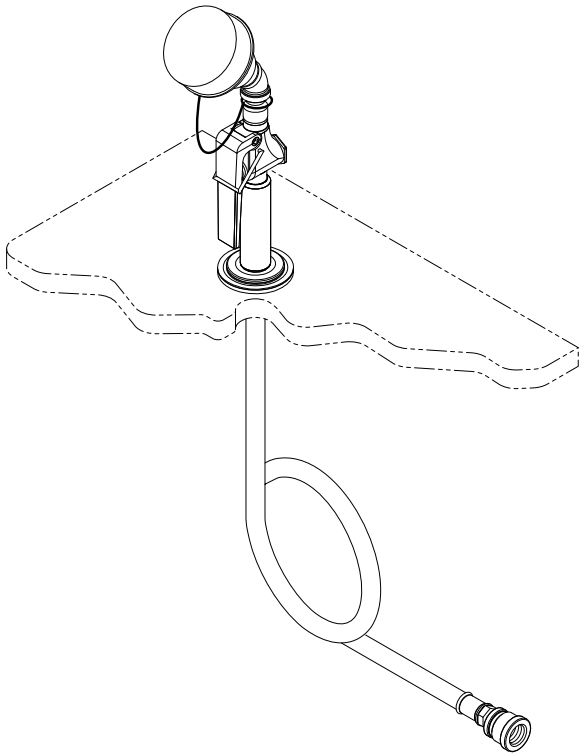
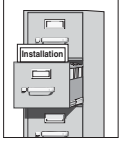

Table of Contents

Pre-Installation Information	2
Installation Instructions	2
Assembly of Components	3
Parts List	3

⚠ IMPORTANT ⚠



Read this installation manual completely to ensure proper installation, then file it with the owner or maintenance department. Compliance and conformity to drain requirements and other local codes and ordinances is the responsibility of the installer.



Separate parts from packaging and make sure all parts are accounted for before discarding any packaging material. If any parts are missing, do not begin installation until you obtain the missing parts.

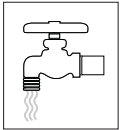

Flush the water supply lines before beginning installation and after installation is complete. Test the unit for leaks and adequate water flow. Main water supply to the eyewash should be "ON" at all times. Provisions shall be made to prevent unauthorized shutoff.



The ANSI Z358.1 standard requires an uninterrupted supply of flushing fluid at a minimum 30 PSI (0.21 MPa) flowing pressure. Flushing fluid should be tepid per ANSI Z358.1.

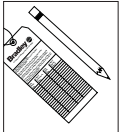

The inspection and testing results of this equipment should be recorded weekly to verify proper operation. This equipment should be inspected annually to ensure compliance with ANSI Z358.1.



Workers who may come in contact with potentially hazardous materials should be trained regarding the placement and proper operation of emergency equipment per ANSI Z358.1.



For questions regarding the operation or installation of this product, visit www.bradleycorp.com or call 1-800-BRADLEY.

Product warranties and service parts information may also be found under "Products" on our web site at www.bradleycorp.com.

Installation

Supplies Required:

- 1/2" NPT water supply
- Backflow prevention device as required by UPC, IPC and/or local plumbing codes

Step 1: Prepare deck for installation

1. Rough-in 1/2" NPT supply piping from wall where drench hose is desired (piping supplied by installer).
2. Select desired location in deck for drench hose and drill a 1-5/16" (34mm) diameter hole.
3. Install the drain plug using the washers and locknut provided (refer to page 3).

Step 2: Install Drench Hose

1. Install the drench hose components as shown on page 3.
 - Apply pipe sealant (supplied by installer) to all male-threaded pipe joints.

Step 3: Connect water supply

1. Connect the end of the drench hose to the 1/2" NPT water supply piping (supplied by installer).
2. Open the water supply lines and test for leaks and adequate water flow.

Assembly of Components and Parts List

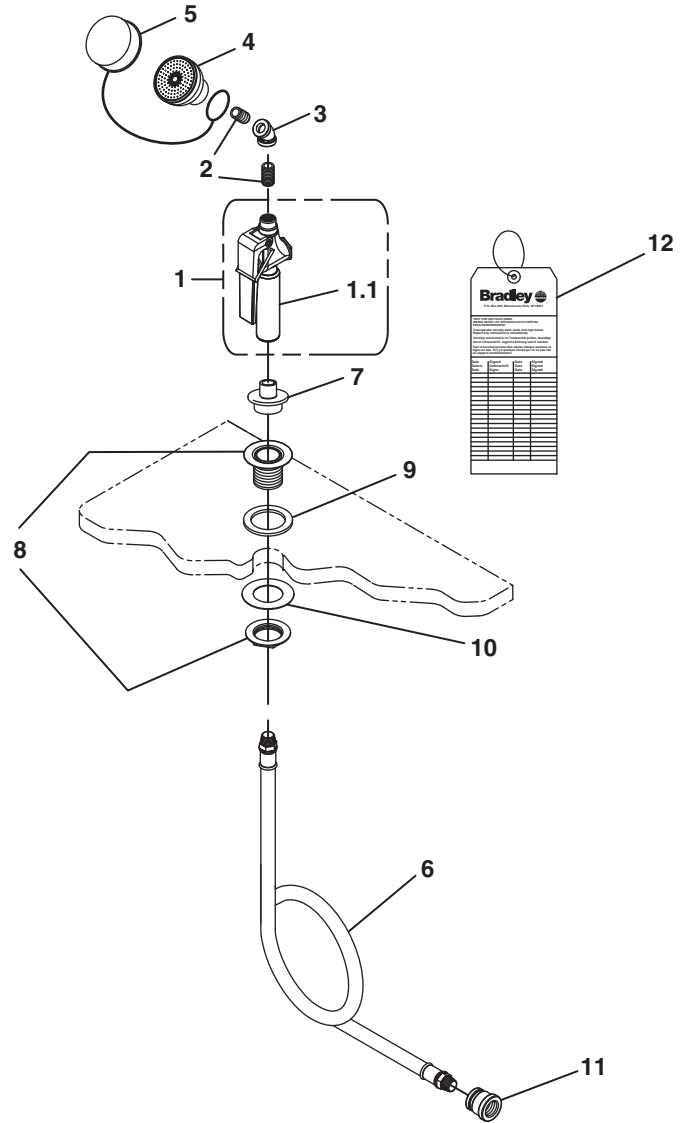
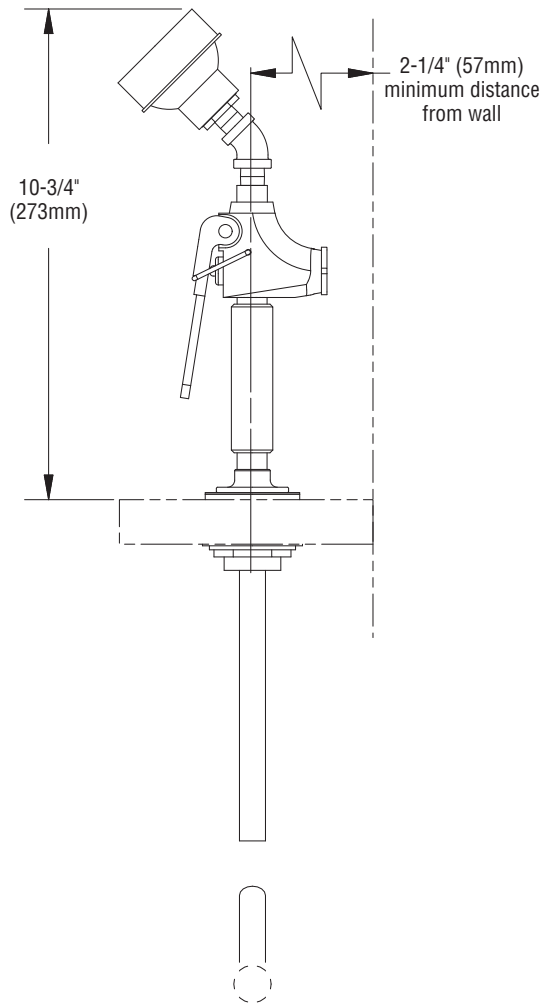

Item	Part No.	Qty	Description	Item	Part No.	Qty	Description
1	S27-265	1	Valve Assembly	7	153-380	1	Adapter
1.1	269-661	1	Valve Handle only	8	S29-092	1	Drain Flange Assembly
2	113-544A	1	Closed Nipple	9	125-001CE	1	Washer, Rubber
3	169-1006	1	1/4 45 Elbow	10	169-875	1	Washer
4	S05-158	1	EFW Assembly	11	169-059	1	Reducing Coupling
5	S53-063	1	Dust Cover	12	204-421	1	Emergency Inspection Tag
6	S89-002	1	3/8" Yellow Tube				