



INSTALLATION, OPERATION & MAINTENANCE INSTRUCTIONS

1455 Kleppe Lane ♦ Sparks, NV 89431-6467 ♦ (775) 359-4712 ♦ Fax (775) 359-7424
E-mail: haws@hawsco.com ♦ website: www.hawsco.com

No. 2080067(10)

Model 7610 Eye/Face Wash

NOTE TO INSTALLER: Please leave this information with the Maintenance Department.

LIMITED WARRANTY

HAWS® warrants that all of its products are guaranteed against defective material or poor workmanship for a period of **one year from date of shipment**. HAWS liability under this warranty shall be discharged by furnishing without charge F.O.B. HAWS Factory any goods, or part thereof, which shall appear to the Company upon inspection to be of defective material or not of first class workmanship, provided that claim is made in writing to company within a reasonable period after receipt of the product. Where claims for defects are made, the defective part or parts shall be delivered to the Company, prepaid, for inspection. HAWS will not be liable for the cost of repairs, alterations or replacements, or for any expense connected therewith made by the owner or his agents, except upon written authority from HAWS, Sparks, Nevada. HAWS will not be liable for any damages caused by defective materials or poor workmanship, except for replacements, as provided above. Buyer agrees that Haws has made no other warranties either expressed or implied in addition to those above stated, except that of title with respect to any of the products or equipment sold hereunder and that HAWS shall not be liable for general, special, or consequential damages claimed to arise under the contract of sale.

The emergency equipment manufactured by HAWS is warranted to function if installation and maintenance instructions provided are adhered to. The units also must be used for the purpose, which they were intended. This product is intended to supplement first-aid treatment. Due to widely varying conditions HAWS cannot guarantee that the use of this emergency equipment will prevent serious injury or the aggravation of existing or prior injuries.

**NO OTHER WARRANTIES EXPRESSED OR IMPLIED ARE AUTHORIZED,
PROVIDED OR GIVEN BY HAWS.**

**SHOULD YOU EXPERIENCE DIFFICULTY WITH THE INSTALLATION OF THIS
MODEL, PLEASE CALL:**

1-800-766-5612

FOR PARTS CALL:

1-800-758-9378

**(U.S.A. AND CANADA ONLY) MONDAY-THURSDAY: 6:00 A.M. – 4:00 P.M. PST
FRIDAY: 6:00 A.M – 1:00 P.M. PST**

LOCATION OF UNIT: The Model 7610 Eye/Face wash should be installed in close proximity to potential accident areas. It should be clearly identified free from obstructions and easy to access.

SUPPLY LINE: The minimum recommended line size is 1/2" IPS with 30-90 psi (2-6 ATM) pressure. Where sediment or mineral content is a problem, an inlet filter is recommended.

PLUMBING CONNECTIONS: Inlet supply is 1/2" O.D. slip joint.

TROUBLESHOOTING

PROBLEM	REPAIR CHECKLIST
1. No flow.	1. Check the main shut-off valve.
2. Insufficient water flow.	2. a. Verify minimum 30 psi (2 ATM) flowing supply line pressure. b. Probable clogging of flow control due to inadequate line flushing. Unscrew eye/face wash head and remove the four screws to disassemble head. Clean flow control and reassemble head.
3. Eyewash stream does not meet desired eye level.	3. a. Possible blocked flow control, see above solution. b. Possible non-leveled eyewash assembly.

INSTALLATION INSTRUCTIONS

Refer to installation drawing to clarify installation procedure.

Note: Model 7610 Eye/Face Wash can be mounted on either right or left side of the sink. For left hand use, reconfigure as shown on installation drawing.

STEP 1: Remove the 1.25 O.D. flange nut and washer from valve body.

STEP 2: After making sure that top and bottom surface of the counter top or deck, around the drilled hole is clean and free of grease, slide valve through drilled hole from the top.

STEP 3: Reinstall the 1.25" O.D. flange nut and washer. Connect slip joint connection to complete installation.

For more information about Haws products, see our website: www.hawsc.com

PARTS BREAKDOWN



PULLDOWN EYE/FACE WASH LABEL
P/N 0003163821

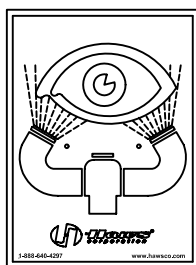

SP175 EYEWASH SIGN



SP170 TEST TAG

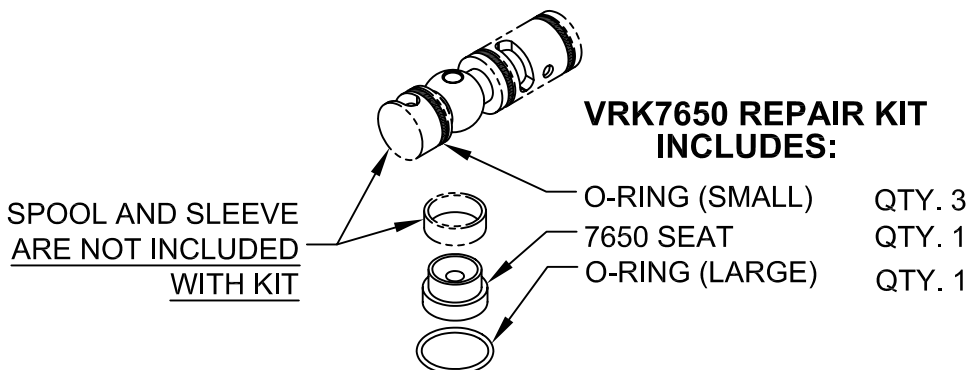
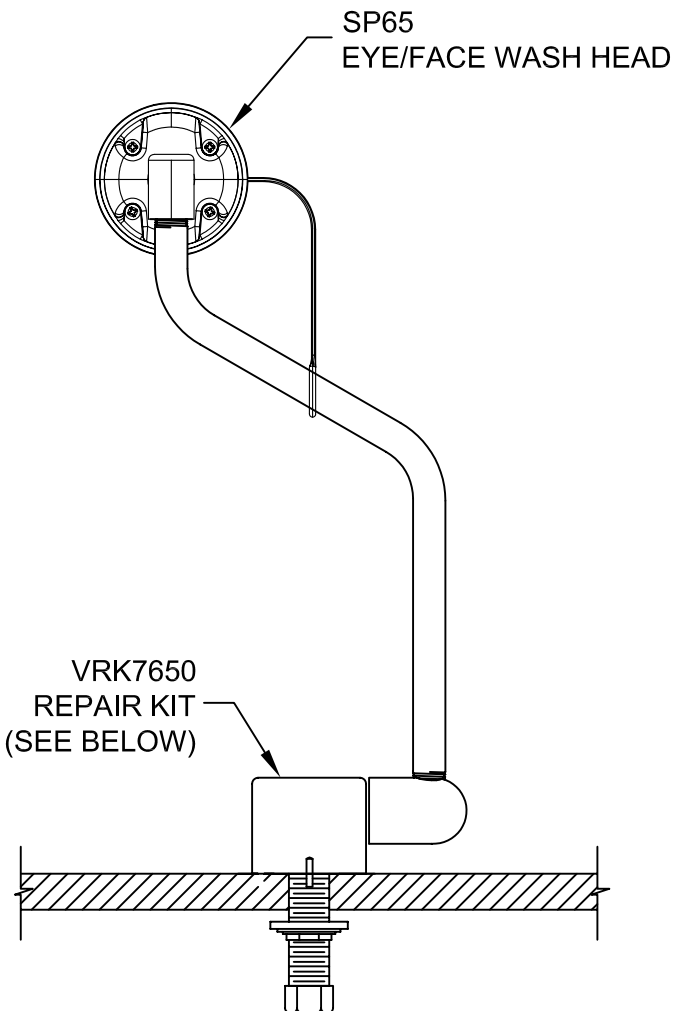

10	UPDATED PER ECN	4367	12/2/09	IR
REV	DESCRIPTION	ECN	DATE	BY/APVD
REVISIONS				

WHEN ORDERING PARTS PLEASE SPECIFY YOUR MODEL NUMBER



1455 KLEPPE LANE
SPARKS, NEVADA 89431
(775) 359-4712 FAX (775) 359-7424
E-MAIL: HAWS@HAWS.CO.COM
WEBSITE: WWW.HAWS.CO.COM

DRAWN BY: STH	DATE: 10/29/96	CHECK BY:	APPVD BY:	SCALE: 1/2
TITLE: 7610 PULL DOWN EYE/FACE WASH			PART NUMBER: 0002080067	
DRAWING TYPE: PARTS BREAKDOWN			DRAWING NUMBER: 12689C00	REV: 10

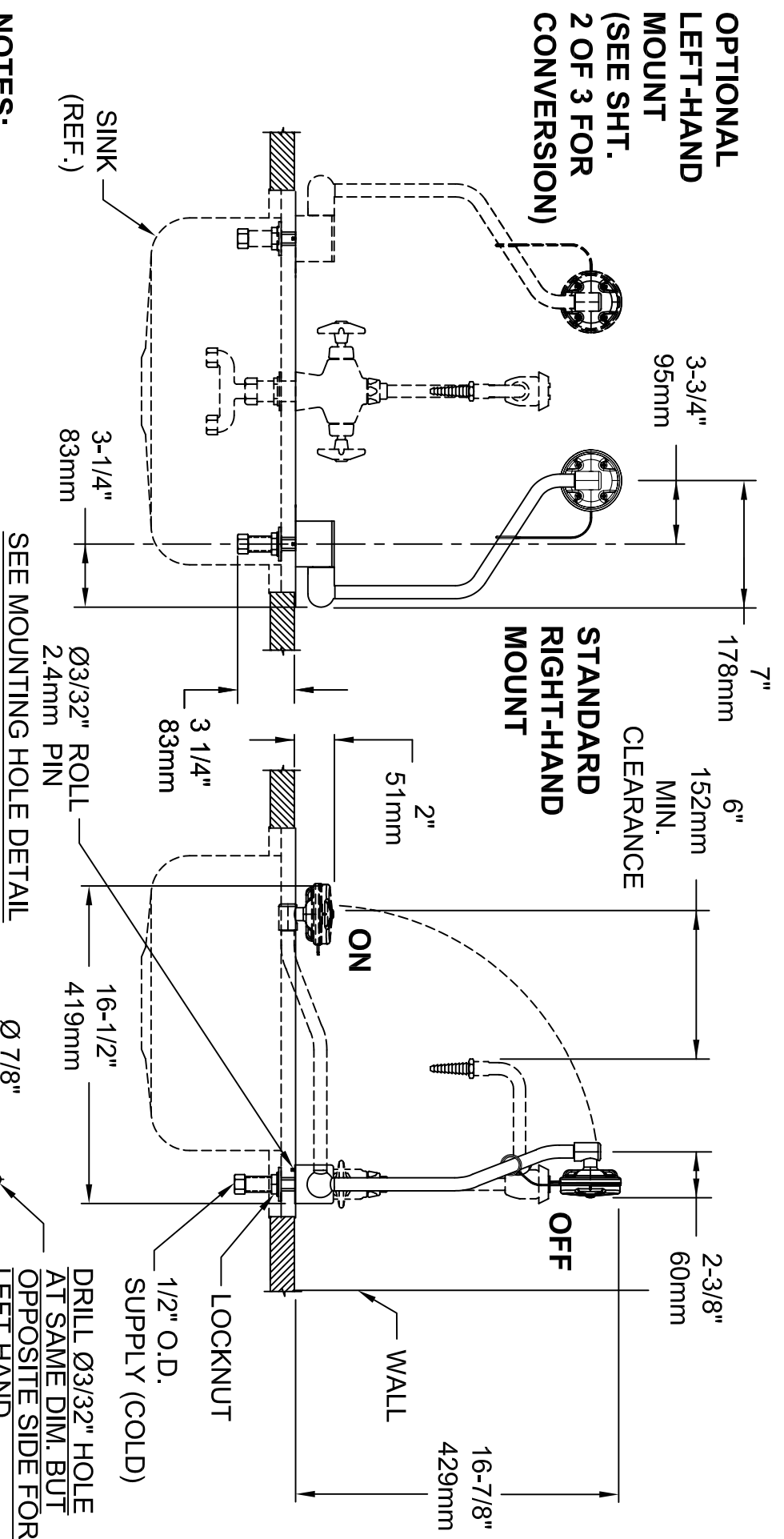

- NOTES:**
1. THE ANSI Z358.1-2009 STANDARD SPECIFIES EYEWASH NOZZLE HEIGHTS TO BE 83.8cm (33 IN.) TO 114.3cm (45 IN.), ABOVE THE FLOOR AND 15.3cm (6 IN.) MINIMUM FROM WALL OR NEAREST OBSTRUCTION.

2. INSTALL SO THAT EYEWASH HEAD IS OVER SINK WHEN ACTIVATED. EYEWASH REQUIRES 4-1/2" [114mm] OF CLEARANCE AROUND HEAD FOR FACEWASH STREAMS.

3. DRILL ONE Ø7/8" [22mm] HOLE AND ONE Ø3/32" HOLE WHERE UNIT IS TO BE INSTALLED. REFER TO MOUNTING HOLE DETAIL.

4. THESE DIMENSIONS MAY VARY ±1/2" [6.4mm].

SEE MOUNTING HOLE DETAIL

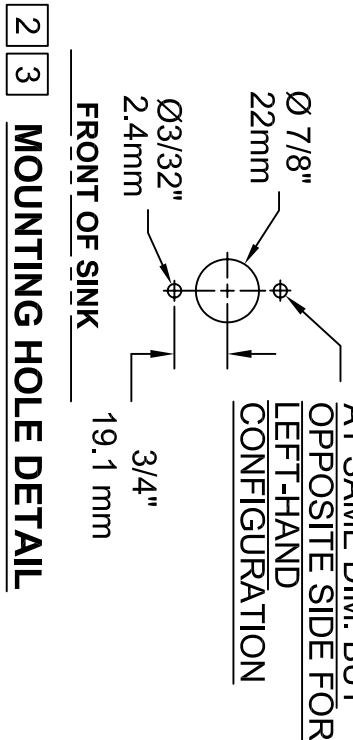

2 3 MOUNTING HOLE DETAIL



1455 KLEPPE LANE
 SPARKS, NEVADA 89431
 (775) 359-4712 FAX (775) 359-7424
 E-MAIL: HAWS@HAWS.CO.COM
 WEBSITE: WWW.HAWS.CO.COM

REVNO: 2006	DATE: 10/96	ECN: 4345	HR: 7610	MODELS: 7610	INFO FAX DOC #: 27610	REVNO: 00000067.D	DATE: 12/69	SIZE: A	SHEET: 1 OF 3
DESIGNER: JF	DATE: 10/96	ECN: 4345	HR: 7610	MODELS: 7610	INFO FAX DOC #: 27610	DATE: 12/69	SIZE: A	SHEET: 1 OF 3	
DRAWING TYPE: INSTALLATION/EXHIBIT					DRAWING NO.: 12691A00				

PROCEDURE FOR LEFT-HAND CONVERSION

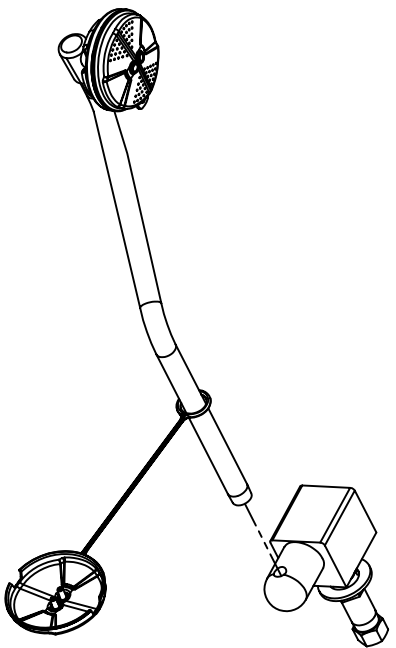

STEP 1:
 (SHOWN IN CLOSED POSITION)
 REMOVE BEND FROM BODY. HAWS RECOMMENDS THE USE OF A SOFT TOOTH VICE TO PREVENT MARKINGS ON CHROME PLATED PARTS THROUGHOUT ENTIRE PROCEDURE.

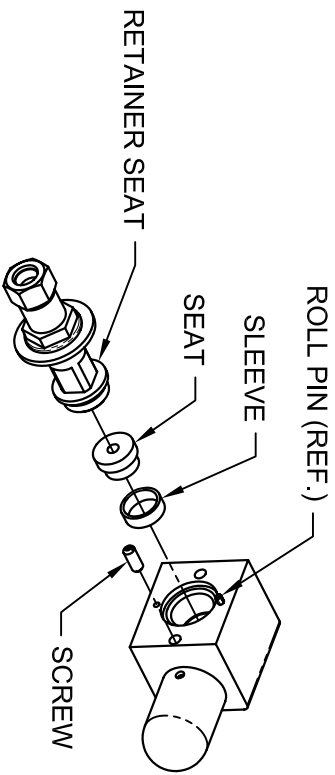

STEP 3:
 REMOVE RETAINER SEAT, SLEEVE AND SEAT FROM BODY. REMOVE SCREW.

EYEWASH ASSEMBLY

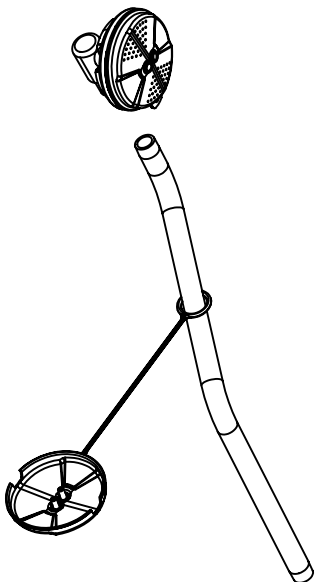

STEP 2:
 REMOVE EYEWASH ASSEMBLY FROM BEND.

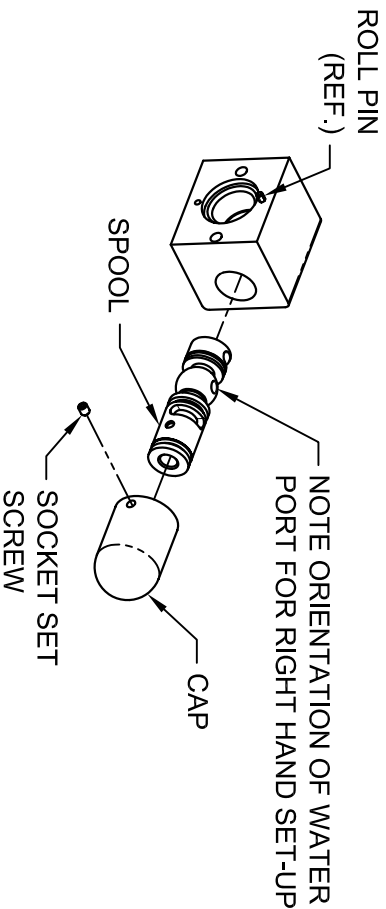

STEP 4:
 LOOSEN AND BACK OFF SOCKET SET SCREW WITH 3/32" HEX WRENCH. REMOVE CAP AND SPOOL. NOTE EXISTING ORIENTATION WATER PORT IN R.H. CLOSED POSITION.



1455 KLEPPE LANE
 SPARKS, NEVADA 89431
 (775) 359-4712 FAX (775) 359-7424
 E-MAIL: HAWS@HAWS.CO.COM
 WEBSITE: WWW.HAWS.CO.COM

FORM NO. 3906	REVISIONS	DATE	BY	DESCRIPTION
7610	1	5/10/07	JF	REVISED FOR LEFT HAND CONVERSION
MODEL(S): 7610				
INFO FAX DOC #: 27610				
SCALE: 1:1				
DRAWING TYPE: INSTALLATION/BACK				
DATE: 5/10/07	APPROVED:	DATE: 5/10/07	BY: JF	DESCRIPTION: 12691A00
SHEET 2 OF 3				

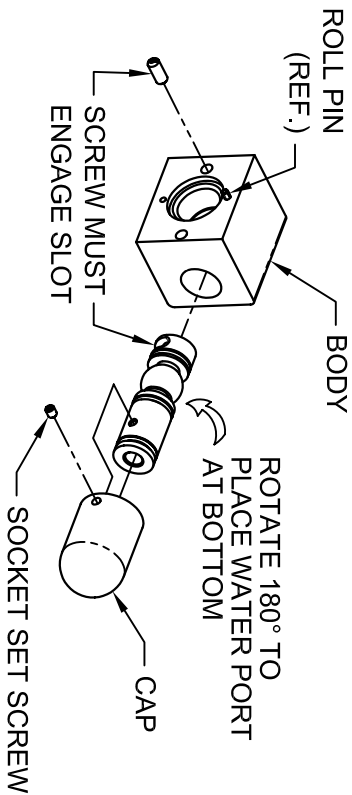

STEP 5:
 ROTATE SPOOL 180°, INSERT INTO BODY. INSERT SCREW AT LEFT SIDE OF BODY, SCREW MUST ENGAGE SLOT ON SPOOL. ATTACH CAP, SECURE WITH SOCKET SET SCREW. (THIS IS NOW IN L.H. CLOSED POSITION).

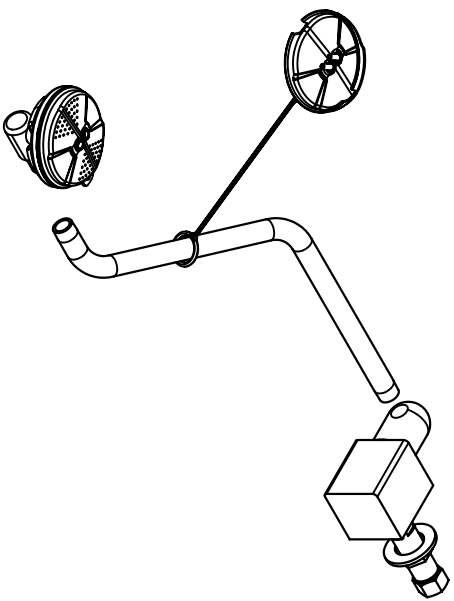

STEP 7:
 ATTACH BEND TO BODY, THEN HEAD ASSEMBLY TO BEND, SEE STEP 8 FOR ORIENTATION OF BEND. USE LOCITITE #565 THREAD SEALANT ON MALE THREADS OF BEND (EACH END).

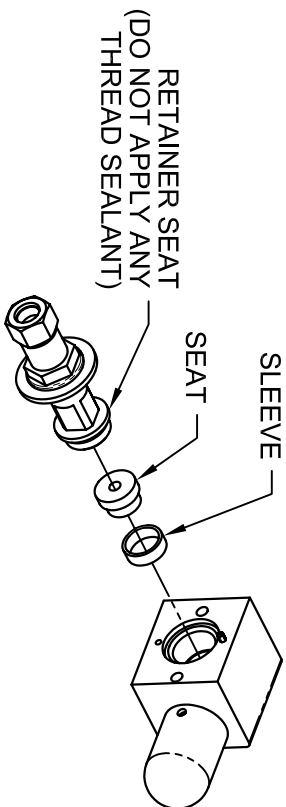

STEP 6:
 INSERT SLEEVE, SEAT AND SCREW RETAINER SEAT TIGHTLY.

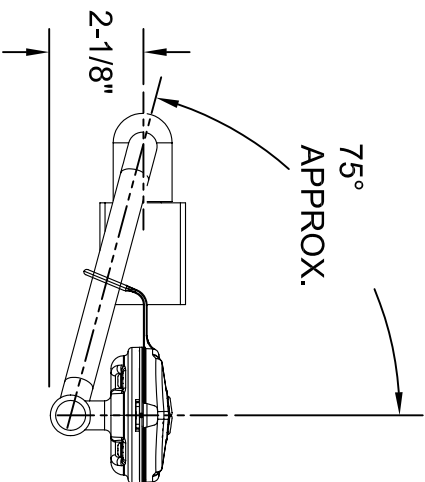

STEP 8:
 NOTE PROPER ORIENTATION OF BEND; 2-1/8" FROM CENTER OF BODY TO CENTER OF EYEWASH TEE. THE 75° IS FOR REFERENCE ONLY.

UPON COMPLETION CHECK FOR PROPER DIRECTION OF ACTIVATION AND FOR LEAKS.

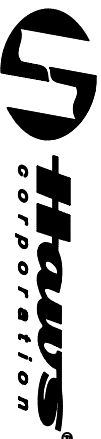

1455 KLEPPE LANE
 SPARKS, NEVADA 89431
 (775) 359-4712 FAX (775) 359-7424
 E-MAIL: HAWS@HAWS.CO.COM
 WEBSITE: WWW.HAWS.CO.COM

FORM NO. 2068	REVISIONS	DATE	DESCRIPTION
2068	ECH-4367	HR	7/6/10
DATE	5/1/07	APPROVED	
MODEL(S):	INFO FAX DOC #:	27/6/10	
PREPARED BY:	DATE:	27/6/10	
SCALE:	PREPARED BY:	DATE:	
SIZE: A	SHEET: 3	OF: 3	
QUANTITY:	0002080067.D		
DATE:	12/6/10		