



# INSTALLATION, OPERATION & MAINTENANCE INSTRUCTIONS

1455 Kleppe Lane ♦ Sparks, NV 89431-6467 ♦ (775) 359-4712 ♦ Fax (775) 359-7424  
HAWS AG ♦ Bachweg 3 ♦ CH-3401 Burgdorf ♦ Switzerland  
Haws Mfg. Pte Lt. ♦ 2A Sungei Kadet Drive ♦ Singapore 729554  
Avlis-Avenida Senador, Testonio Vilela ♦ 505 Jardim Aeroporto ♦ Itu, S.P. 13304-550 ♦ Brasil  
E-mail: [haws@hawsco.com](mailto:haws@hawsco.com) ♦ website: [www.hawsco.com](http://www.hawsco.com)

No. 2067460(9)

## Model 8309PCP Polished Chrome Plated Combination Shower Eye/Face Wash

**NOTE TO INSTALLER: Please leave this information with the Maintenance Department.**

### LIMITED WARRANTY

HAWS® warrants that all of its products are guaranteed against defective material or poor workmanship for a period of **one year from date of shipment**. HAWS liability under this warranty shall be discharged by furnishing without charge F.O.B. HAWS Factory any goods, or part thereof, which shall appear to the Company upon inspection to be of defective material or not of first class workmanship, provided that claim is made in writing to company within a reasonable period after receipt of the product. Where claims for defects are made, the defective part or parts shall be delivered to the Company, prepaid, for inspection. HAWS will not be liable for the cost of repairs, alterations or replacements, or for any expense connected therewith made by the owner or his agents, except upon written authority from HAWS, Sparks, Nevada. HAWS will not be liable for any damages caused by defective materials or poor workmanship, except for replacements, as provided above. Buyer agrees that Haws has made no other warranties either expressed or implied in addition to those above stated, except that of title with respect to any of the products or equipment sold hereunder and that HAWS shall not be liable for general, special, or consequential damages claimed to arise under the contract of sale.

The emergency equipment manufactured by HAWS is warranted to function if installation and maintenance instructions provided are adhered to. The units also must be used for the purpose, which they were intended. This product is intended to supplement first-aid treatment. Due to widely varying conditions HAWS cannot guarantee that the use of this emergency equipment will prevent serious injury or the aggravation of existing or prior injuries.

**NO OTHER WARRANTIES EXPRESSED OR IMPLIED ARE AUTHORIZED, PROVIDED OR GIVEN BY HAWS.**

**SHOULD YOU EXPERIENCE DIFFICULTY WITH THE INSTALLATION OF THIS MODEL, PLEASE CALL:**

**1-800-766-5612**

**FOR PARTS CALL:**

**1-800-758-9378**

**(U.S.A. AND CANADA ONLY) MONDAY-THURSDAY: 6:00 A.M. – 4:00 P.M. PST  
FRIDAY: 6:00 A.M – 1:00 P.M. PST**

**LOCATION OF UNIT:** The Model 8309PCP Polished Chrome Plated Combination Eye/Face Wash should be installed in close proximity to potential accident areas. It should be clearly identified, free from obstructions and easy to access.

**SUPPLY LINE:** The minimum recommended line size is 1-1/4" IPS with 30-90 psi (2-6 ATM) flowing pressure. Where sediment or mineral content is a problem, an inlet filter is recommended.

**PLUMBING CONNECTIONS:** Inlet supply is male 1-1/4" IPS. Waste outlet is male 1-1/4" IPS.

## INSTALLATION PROCEDURE

Refer to Installation Drawing for clarification. Check parts list to insure all required parts are included. Use pipe joint sealant PST #565 (Loctite) on all connections.

- Step 1:** Prepare the emergency shower foundation by using the floor flange as a template. Locate the three holes for the 3/8-16 UNC x 6" anchor bolts (not supplied). They should extend 1" above the floor level.
- Step 2:** Once the concrete foundation is ready (dry), assemble the floor flange of the lower pipe assembly to the anchor bolts; then securely fasten with 3/8-16 UNC Hex Nuts and 3/8" washers (not supplied).
- Step 3:** Attach (1-1/4" x 1-1/4") coupling to lower pipe assembly and tighten, grabbing the waste bend of loop assembly for leverage.
- Step 4:** Attach upper pipe assembly to coupling and tighten using a cheater bar in side opening of supply inlet.
- Step 5:** Attach valve assembly with a spud wrench.
- Step 6:** Attach upper bend to valve using a cheater bar in opening of the bend to tighten and attach the showerhead onto the bend.
- Step 7:** Assemble the sign onto the unit. Use the strap, screws, washers and nuts provided, to mount the sign onto the upright. The sign should be positioned for maximum visibility.
- Step 8:** Attach a (1-1/4") cap (not supplied) onto the optional supply line tee that is not used. Before connecting the supply water line to the emergency shower, **flush the line thoroughly.**

<b>TROUBLESHOOTING</b>	
<b>PROBLEM</b>	<b>REPAIR CHECKLIST</b>
1. No flow.	1. Check the main shut-off valve.
2. Insufficient water flow, shower and eyewash.	2. Verify minimum 30 psi (2 ATM) flowing supply line pressure.
3. Insufficient water flow on eyewash, however, shower is sufficient.	3. a. Verify minimum 30 psi (2 ATM) flowing supply line pressure. b. Probable clogging of flow control due to inadequate line flushing. Turn water supply off. Unscrew eyewash heads off to clean flow controls. c. Unscrew eye/face wash head cap off to gain access to the buffer and clean it.
4. Eyewash stream does not meet desired eye level.	4. a. Possible blocked flow control, see above solution. b. Possible non-leveled eyewash assembly.
5. Water does not drain properly.	5. a. Check your drain system for debris. b. Check the main waste line of your building to see if it does handle the capacity required for the entire drainage system.
6. Insufficient water flow at the showerhead.	6. a. Verify minimum 30 psi (2 ATM) flowing supply line pressure. b. Probable clogging of flow control inside showerhead. Unscrew showerhead off of elbow and clean rubber flow control.

# PARTS BREAKDOWN

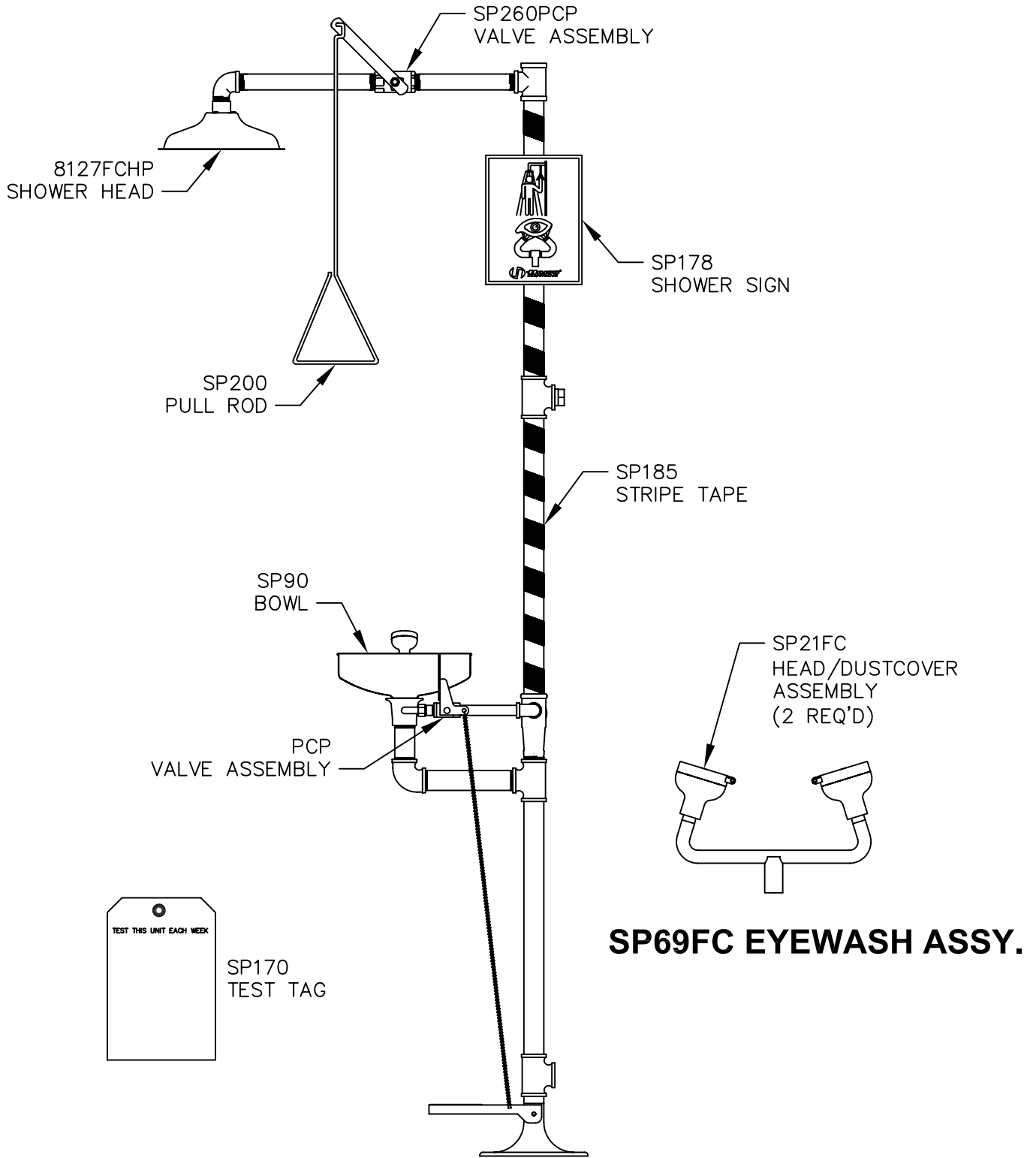

<b>WHEN ORDERING PARTS PLEASE SPECIFY YOUR MODEL NUMBER</b>			1455 KLEPPE LANE SPARKS, NEVADA		BACHWEG 3 CH3401 BURGENDORF SWITZERLAND	
			DRAWN BY: D OLLOM	DATE: 7 /26/96	CHECK BY:	APP'D BY:
	TITLE: MODEL 8309PCP				PART NUMBER: 0002067460	
	DRAWING TYPE: PARTS BREAKDOWN				DRAWING NUMBER: 12549C00	

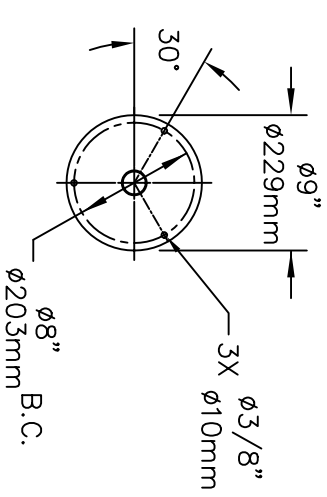
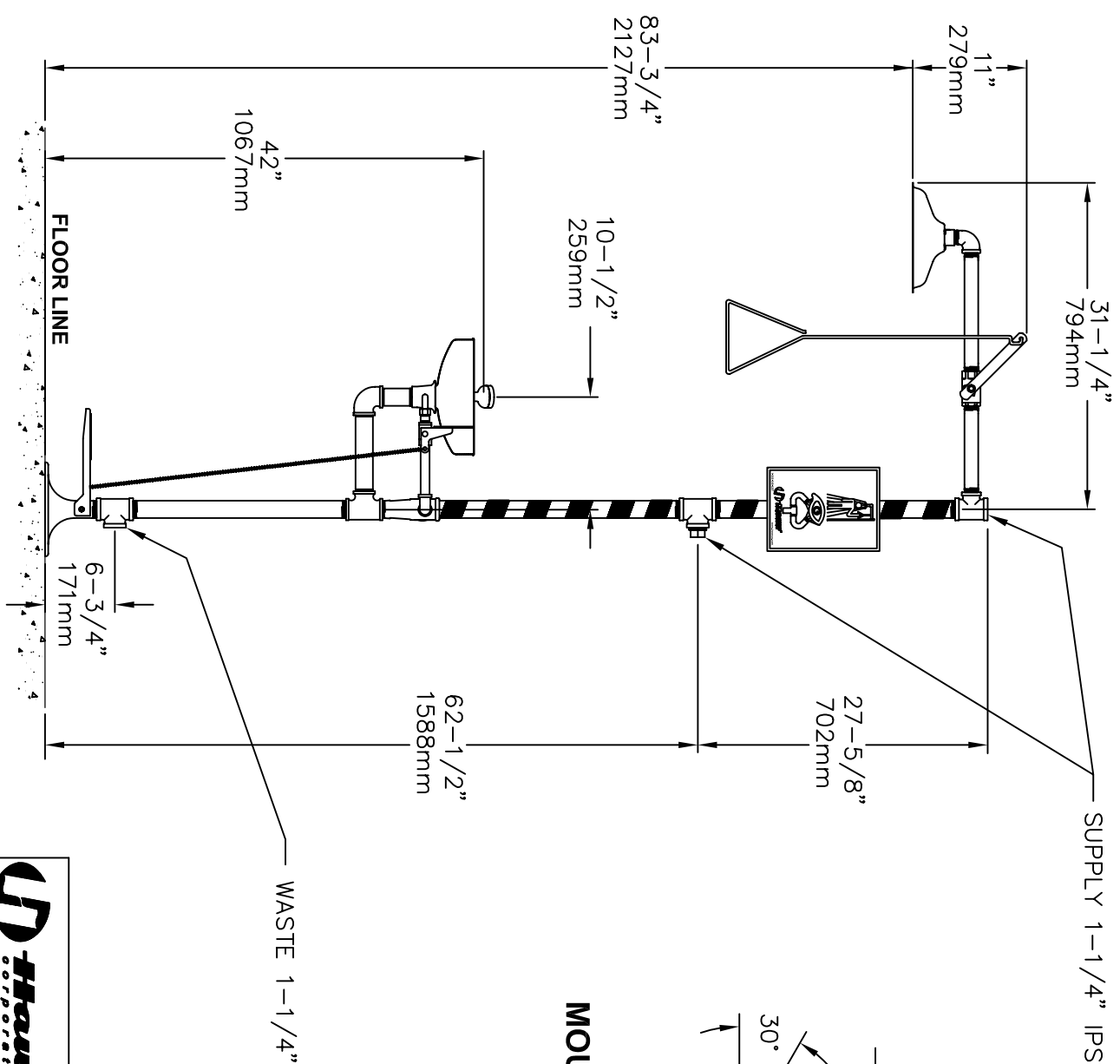

**MOUNTING DETAIL**

<b>Haws Corporation</b>		<b>MODEL(S):</b> 8309P CP	
REG. NO. 8309P	REV. 11/06	DATE 9/96	SCALE 1:1
DESIGNED BY EONE 3/94	CHKD BY	DATE	APPROVED
INFO FAX : 1-888-FAX-HAWS (1-888-329-4297)		DRAWING TYPE: INSTALLATION/FABRICK	
1455 Kiappa Ln, Sparks NV, 89431		PHONE: 775-359-4712	
Haws AG, Burgdorf, Switzerland		FAX: 775-359-7424	
Haws Mfg Pte Ltd, Singapore		CH: 3401, Burgdorf Loop, Singapore 729531	
e-trail: Haws@hawsco.com		website: www.hawsco.com	
DATE: 02/07/06	REV: 7460 D	DATE: 02/07/06	REV: 7460 D
SIZE: A	SHEET: 1 OF 1	DATE: 02/07/06	REV: 7460 D