



INSTALLATION, OPERATION & MAINTENANCE INSTRUCTIONS

1455 Kleppe Lane ♦ Sparks, NV 89431-6467 ♦ (775) 359-4712 ♦ Fax (775) 359-7424
HAWS AG ♦ Bachweg 3 ♦ CH-3401 Burgdorf ♦ Switzerland
Haws Mfg. Pte Lt. ♦ 2A Sungei Kadet Drive ♦ Singapore 729554
Avlis-Avenida Senador, Testonio Vilela ♦ 505 Jardim Aeroporto ♦ Itu, S.P. 13304-550 ♦ Brasil
E-mail: haws@hawsco.com ♦ website: www.hawsco.com

No. 2081781 (7)

Model 8317CTFP (120V) & 8317CTFP.220V

NOTE TO INSTALLER: Please leave this information with the Maintenance Department.

LIMITED WARRANTY

HAWS® warrants that all of its products are guaranteed against defective material or poor workmanship for a period of **one year from date of shipment**. HAWS liability under this warranty shall be discharged by furnishing without charge F.O.B. HAWS Factory any goods, or part thereof, which shall appear to the Company upon inspection to be of defective material or not of first class workmanship, provided that claim is made in writing to company within a reasonable period after receipt of the product. Where claims for defects are made, the defective part or parts shall be delivered to the Company, prepaid, for inspection. HAWS will not be liable for the cost of repairs, alterations or replacements, or for any expense connected therewith made by the owner or his agents, except upon written authority from HAWS, Sparks, Nevada. HAWS will not be liable for any damages caused by defective materials or poor workmanship, except for replacements, as provided above. Buyer agrees that Haws has made no other warranties either expressed or implied in addition to those above stated, except that of title with respect to any of the products or equipment sold hereunder and that HAWS shall not be liable for general, special, or consequential damages claimed to arise under the contract of sale.

The emergency equipment manufactured by HAWS is warranted to function if installation and maintenance instructions provided are adhered to. The units also must be used for the purpose, which they were intended. This product is intended to supplement first-aid treatment. Due to widely varying conditions HAWS cannot guarantee that the use of this emergency equipment will prevent serious injury or the aggravation of existing or prior injuries.

NO OTHER WARRANTIES EXPRESSED OR IMPLIED ARE AUTHORIZED, PROVIDED OR GIVEN BY HAWS.

SHOULD YOU EXPERIENCE DIFFICULTY WITH THE INSTALLATION OF THIS MODEL, PLEASE CALL:

1-800-766-5612

FOR PARTS CALL:

1-800-758-9378

**(U.S.A. AND CANADA ONLY) MONDAY-THURSDAY: 6:00 A.M. – 4:00 P.M. PST
FRIDAY: 6:00 A.M – 1:00 P.M. PST**

RECOMMENDED TOOLS: Pipe joint sealant, screwdriver, pipe wrench, three (3) rust resistant anchors (3/8" diameter), silicone caulking, level.

LOCATION OF UNIT: The Model 8317CTFP (120V) & 8317CTFP.220V Emergency Shower Eye / Face Wash should be installed in close proximity to potential accident areas. It should be clearly identified, free from obstructions and easy to access. Suitable for use in Class 1, Division 2 Group B,C,& D areas. Temperature rating T6 (85° C).

ELECTRICAL SUPPLY FOR MODEL 8317CTFP: Electrical power required for standard heat traced unit is **120 VAC**. Average power consumption at 50° F (10° C) ambient temperature is 125 watts. Maximum less lighting is 150 watts. Connection at input junction box is 3/4" NPT. **DURING POTENTIALLY FREEZING PERIODS; INSURE THAT UNIT IS CONNECTED TO A CONTINUOUS POWER SUPPLY.**

ELECTRICAL SUPPLY FOR MODEL 8317CTFP.220V: Electrical power required for standard heat traced unit is **220 VAC**. Average power consumption at 50° F (10° C) ambient temperature is 125 watts. Maximum less lighting is 150 watts. Connection at input junction box is 3/4" NPT. **DURING POTENTIALLY FREEZING PERIODS; INSURE THAT UNIT IS CONNECTED TO A CONTINUOUS POWER SUPPLY.**

WATER SUPPLY: The minimum recommended line is 1-1/4" IPS with 30-90 psi (2-6 ATM) flowing pressure. An inlet filter is recommended where sediment or mineral content is a problem. Inlet connection is 1-1/4" IPS. **WATER SUPPLY MUST BE FREEZE PROTECTED.**

WARNING: Fire and shock hazards. To minimize the danger of fire, if the heating cable is damaged or improperly installed, use a ground fault electrical protection device (30mA GFEPD). Electrical fault currents may be insufficient to trip a conventional circuit breaker. (NEC427-22)

INSTALLATION PROCEDURE

Refer to Installation Drawings for clarification. Use pipe joint sealant on all connections.

Step 1: Prepare the emergency shower foundation locating three 3/8" anchors (not supplied), for shower floor flange. Note flange hole positions so shower head eye/face wash and supply inlet will be in proper direction. Raise shower into position and shim under floor flange if required to maintain upright vertical.

Step 2: Connect water supply as follows: **This model is designed for either a top water supply or a bottom water supply.** This model is shipped with a complete 1-1/4" IPS union connected at the top supply inlet. At the bottom supply inlet there is only half of a 1-1/4" IPS union. The other half of the union is connected to a freeze protection bleed valve located inside the shipping carton. Remove outer half of the 1-1/4" union from the top water inlet. Assemble the half union onto 1-1/4" IPS male thread of either the top or bottom water supply.

Complete supply connection at the desired 1-1/4" union. Attach the other half union with the freeze valve attached to the other unused union and complete the connection. Run the extra heat trace cable over this union and the freeze valve then cover this union and heat trace cable with the 4-3/4" diameter split insulation (supplied). Secure with two cable ties (supplied). Cover the freeze valve and heat trace cable with the smaller diameter foam insulation.

INSTALLATION PROCEDURE...

Turn on water supply and check for leaks, then operation of eye/face wash and shower together. If flow of either is inadequate check troubleshooting chart. Heat trace (supplied), insulate and weather seal inlet union and above ground supply (by others). If flow switch is used, heat-trace and insulate 6" above flow switch tee.

Step 3: Connect electrical power supply conduit to input junction box using suitable conduit fitting into 3/4" NPT inlet. Install optional area light and indicator light, if desired. **For MODEL 8317CTFP (120V):** connect **120 volt AC** line to 16 gauge shower wires as follows: Black = 120 VAC, White = Neutral, Green = Ground.
For MODEL 8317CTFP.220V:
Connect **220 volt AC** line to 16 gauge shower wires as follows: Black = 220 VAC, White = Neutral, Green = Ground. Turn on power supply to complete installation. (See Electrical Schematic Drawing, page 2 of Installation Drawing).

OPERATING INSTRUCTIONS

Power to the 8317CTFP (120V) & 8317CTFP.220V may be left on year round. The non-adjustable thermostat will shut off heat cable when air temperature rises to 55° - 65° F (12° - 18° C). Heat cycle will repeat when air temperature drops to between 45° -55° F (7° - 13°C). Periodic check of water temperature from shower or eye/face wash will confirm normal operating temperatures between 45°- 95°F (7°-35°C).

This unit is heated by low power heat trace cable suitable for freeze protection but not suitable for providing a warm shower from a cold water supply. Moments after activating shower, water temperature will drop to supply temperature.

ANSI recommends a comfortable shower temperature range of 60°F (15°C) to 95°F (35°C). For the protection of the user, we strongly recommend that some system be installed to provide tempered (warm) water to this shower and eye/face wash. Heat trace cable used on this shower heats slowly and may take 90 minutes to complete a full heat cycle.

No drain connection at bleed valve(s) is normally required. Valve(s) will remain closed unless power outage, high ambient temperature (with optional scald protection valve, only) or malfunction occurs (see Troubleshooting).

NOTE: IF GROUND WATER IS BELOW 45°F (7°C) SIMPLY TESTING SHOWER MIGHT CAUSE BLEED VALVE TO OPEN. ONCE OPENED, COLD GROUND WATER WILL KEEP BLEED VALVE OPEN. SEE TROUBLESHOOTING GUIDE FOR PROCEDURE TO CLOSE BLEED VALVE ONCE OPENED.

Periodic tests for proper function of shower and eye/face wash should be performed and recorded on inspection tags attached to unit or in separate maintenance logbook (preferred).

IMPORTANT SAFETY NOTICE

THE NATIONAL ELECTRICAL CODE REQUIRES GROUND-FAULT EQUIPMENT PROTECTION ON EACH HEATING CABLE BRANCH CIRCUIT. TO REDUCE THE RISK OF FIRE CAUSED BY DAMAGE OR IMPROPER INSTALLATION, CIRCUIT BREAKERS SUCH AS SQUARE D QO-EPD AND QOB-EPD OR EQUIVALENT, WITH A 30mA TRIP LEVEL, SHOULD BE USED. PLEASE SUBSTITUTE THESE BREAKERS WHEREVER REFERENCE IS MADE TO CONVENTIONAL BREAKERS IN THIS DOCUMENT. ALTERNATIVE DESIGNS PROVIDING COMPARABLE LEVELS OF GROUND-FAULT PROTECTION MAY ALSO BE ACCEPTABLE.

TROUBLESHOOTING

PROBLEM	REPAIR CHECKLIST
1. Continuous flow from freeze bleed valve.	1. If bleed water temperature is above 45°F (7°C), replace bleed valve. If below 45°F (7°C), verify electric power to unit, then check thermostat. See item 3 below. Once opened, cold supply water, (45°F (7°C) or colder), will keep freeze bleed valve open. To shut bleed valve, it must be warmed above 45°F (7°C) by immersion in hot water by turning off water TEMPORARILY, or by plugging valve TEMPORARILY until heat trace warms water sufficiently to close bleed valve. DO NOT PLUG UNLESS HEAT TRACE IS WORKING PROPERLY. PLUGGED BLEED VALVE OFFERS NO BACKUP FREEZE PROTECTION. DAMAGE MAY OCCUR.
2. Continuous flow from scald bleed valve. (Optional valve).	2. If bleed water temperature is below 90°F (32°C), replace bleed valve. Above 100°F (38°C) may be due to direct sunlight or excess ambient temperature. Otherwise, check thermostat item 3 below.
3. Shower and eye/face wash water temperature below 40°F or above 100°F.	3. Shut off electric power. All electric connections are made inside external junction box. Thermostat is mounted in top port of junction box. Disconnect thermostat leads from terminal block and wire nut in junction box. Check thermostat continuity: open circuit above 65°F (18°C), closed below 45°F (7°C). Thermostat is not adjustable and should be replaced if either of the continuity checks are incorrect. If unit is subject to freezing temperatures, temporarily disconnect thermostat and reconnect wiring to bypass thermostat and protect shower from freezing until replacement thermostat can be installed. Self-regulating heat trace cable will not overheat shower until air temperature rises above 85°F (30°C).
4. Insufficient flow at shower and eye/face wash.	4. Verify minimum 30 PSI (2 ATM), 28 gallon (106 liters per minute) available supply. Check for blockage in lines.
5. Insufficient flow at eye/face wash only.	5. a. Probable clogging of flow control due to inadequate line flushing. Turn water supply off. Unscrew eye/face wash heads off to clean flow controls. b. Unscrew eye/face wash head cap off to gain access to the buffer and clean it.
6. Insufficient water flow at the showerhead, however, eye/face wash is sufficient.	6. Probable clogging of flow control inside showerhead. Unscrew showerhead off of elbow and clean rubber flow control.
7. Shower and eye/face wash valve stem leak.	7. Remove shower arm or eye/face wash push flag. Peel black trim strip from shower and separate housing halves. Peel back or remove insulation to gain access to valve. Remove "U" bracket from valve stem and tighten valve stem hex packing nut to stop leak. Reassemble bracket, insulation, shower housing and valve arm.
8. Shower and eye/face wash valve leaks. (Does not shut off completely).	8. Disconnect power to unit. Disassemble as in item 6. Check valve arm stop tang for damage. Repair or replace valve assembly. Heat cable is looped around valve and should be pulled away from valve. Remove valve. Reverse above steps to reassemble.

PARTS BREAKDOWN

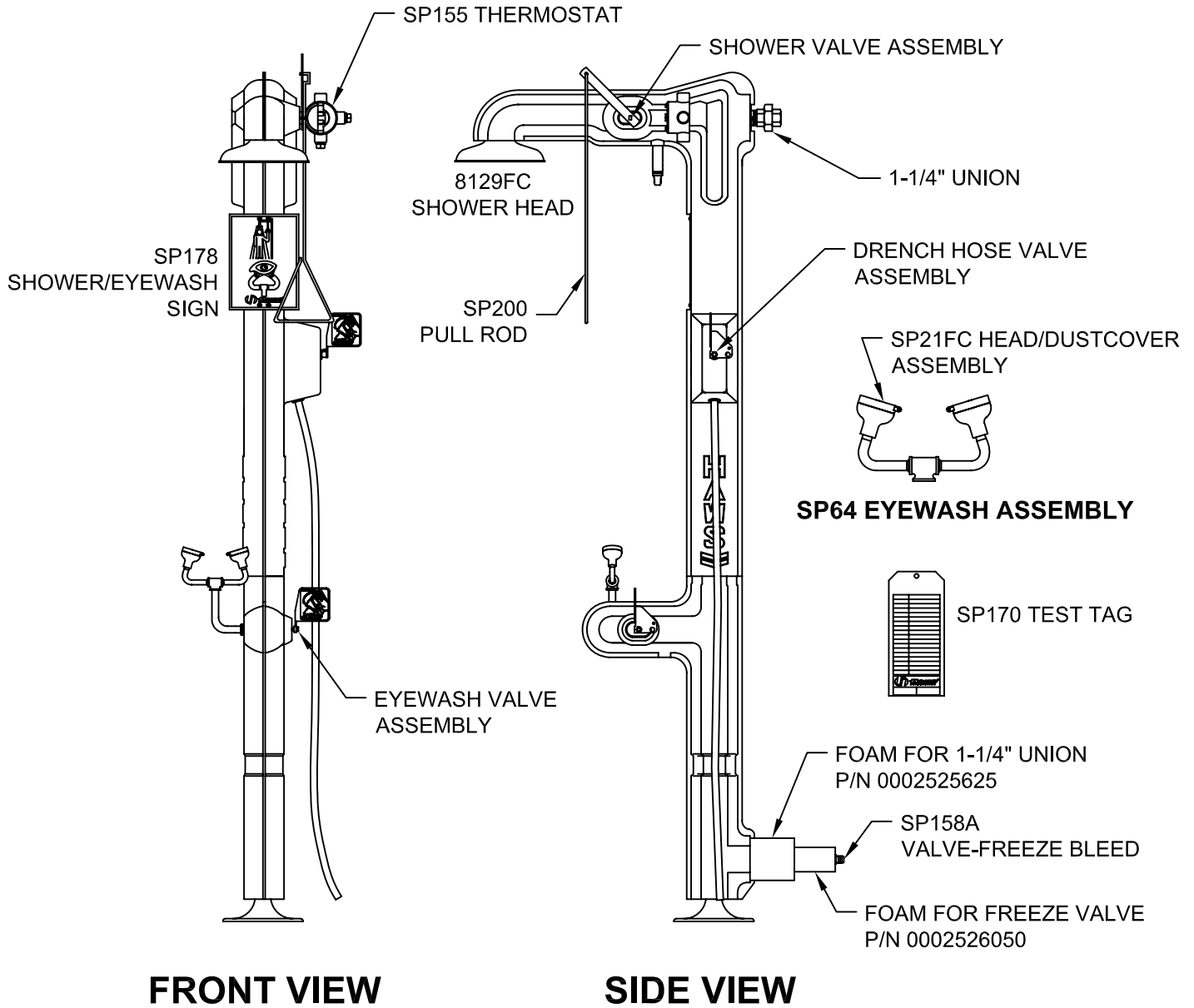

WHEN ORDERING PARTS PLEASE SPECIFY YOUR MODEL NUMBER



1455 KLEPPE LANE SPARKS, NEVADA BACHWEG 3 CH3401 BURGDORF SWITZERLAND

DRAWN BY: RTM	DATE: 03/29/05	CHECK BY:	APP'D BY:	SCALE: 1/9
TITLE: 8317CTFP(120V)/8317CTFP.220V			PART NUMBER: 00020801781	
DRAWING TYPE: PARTS BREAKDOWN			DRAWING NUMBER: 15200C00	REV: 7

THIS DOCUMENT IS TRUE AND CORRECT AT TIME OF PUBLICATION. CONTINUED PRODUCT IMPROVEMENTS MAKE SPECIFICATIONS AND MEASUREMENTS SUBJECT TO CHANGE WITHOUT NOTICE.

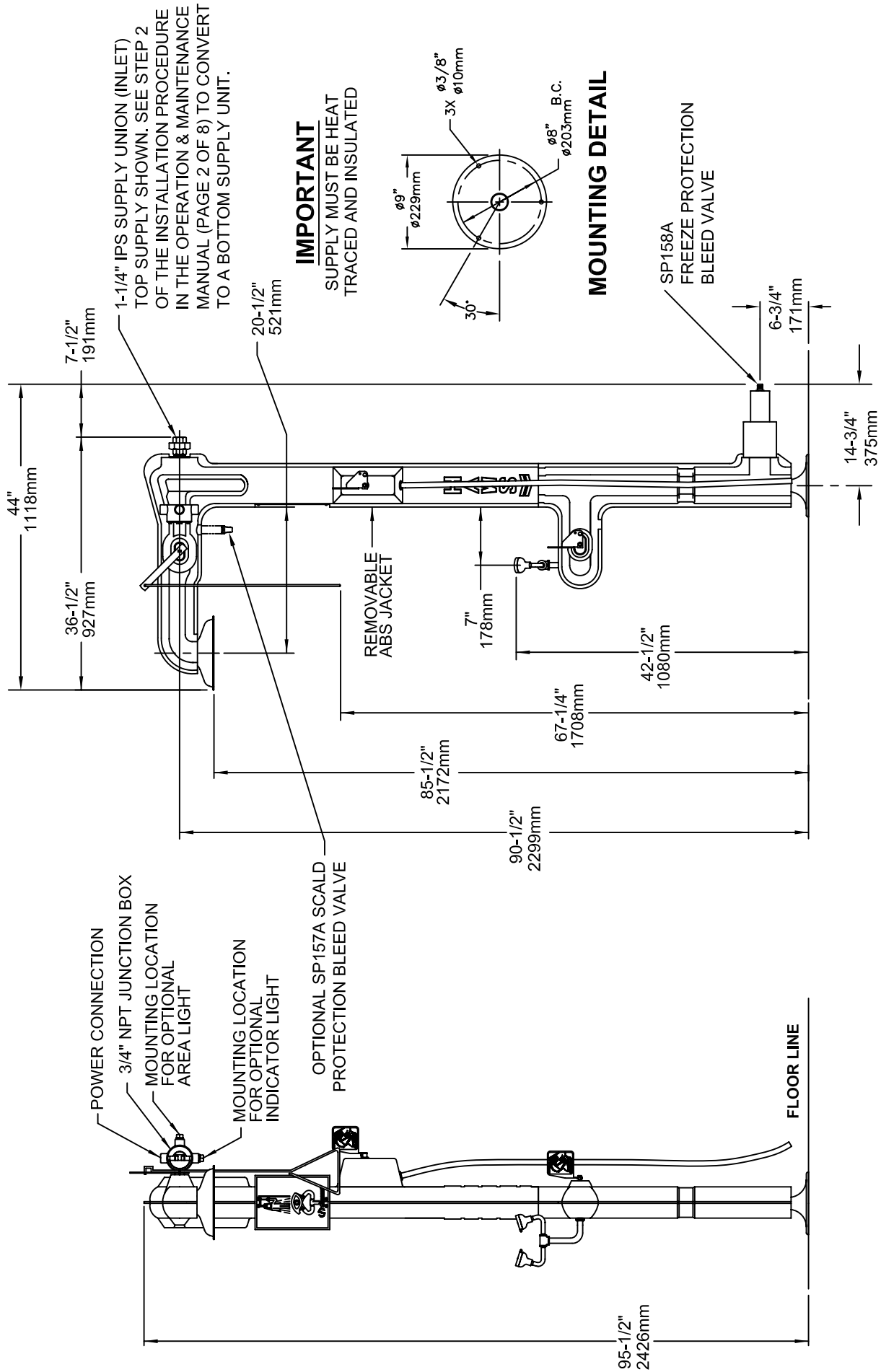

1-1/4" IPS SUPPLY UNION (INLET)
TOP SUPPLY SHOWN. SEE STEP 2
OF THE INSTALLATION PROCEDURE
IN THE OPERATION & MAINTENANCE
MANUAL (PAGE 2 OF 8) TO CONVERT
TO A BOTTOM SUPPLY UNIT.

IMPORTANT
SUPPLY MUST BE HEAT
TRACED AND INSULATED

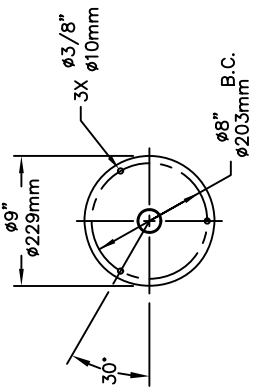

MOUNTING DETAIL

SP158A
FREEZE PROTECTION
BLEED VALVE

Haws Corporation

INFO FAX : 1-888-FAX-HAWS (1-888-329-4297)
1455 Kleppe Ln, Sparks NV, 89431
Phone: 775-359-4712 Fax: 775-359-7424
Haws Ag, Bachweg 3, CH-3401 Burgdorf, Switzerland
Haws Mtg Pte Ltd, 74 Sungei Kadut Loop, Singapore 729531
e-mail: Haws@hawsco.com website: www.hawsco.com

EQ. NO.	REVISED BY	DATE	DRWN	DATE	CHKD	DATE	APPR
	ECN: 4173			03/29/05			

MODEL(S): 8317CTFP(120V)/8317CTFP.220V
INFO. FAX. DOC. #: 2831778
SCALE: 1:20 DRAWING TYPE: INSTALLATION/FABRACK

0000081781.D	15201A00
0000081781.D	15201A00
15201A00	15201A00
15201A00	15201A00

SIZE: A SH: 1 OF 2

THIS DOCUMENT IS TRUE AND CORRECT AT TIME OF PUBLICATION. CONTINUED PRODUCT IMPROVEMENTS MAKE SPECIFICATIONS AND MEASUREMENTS SUBJECT TO CHANGE WITHOUT NOTICE.

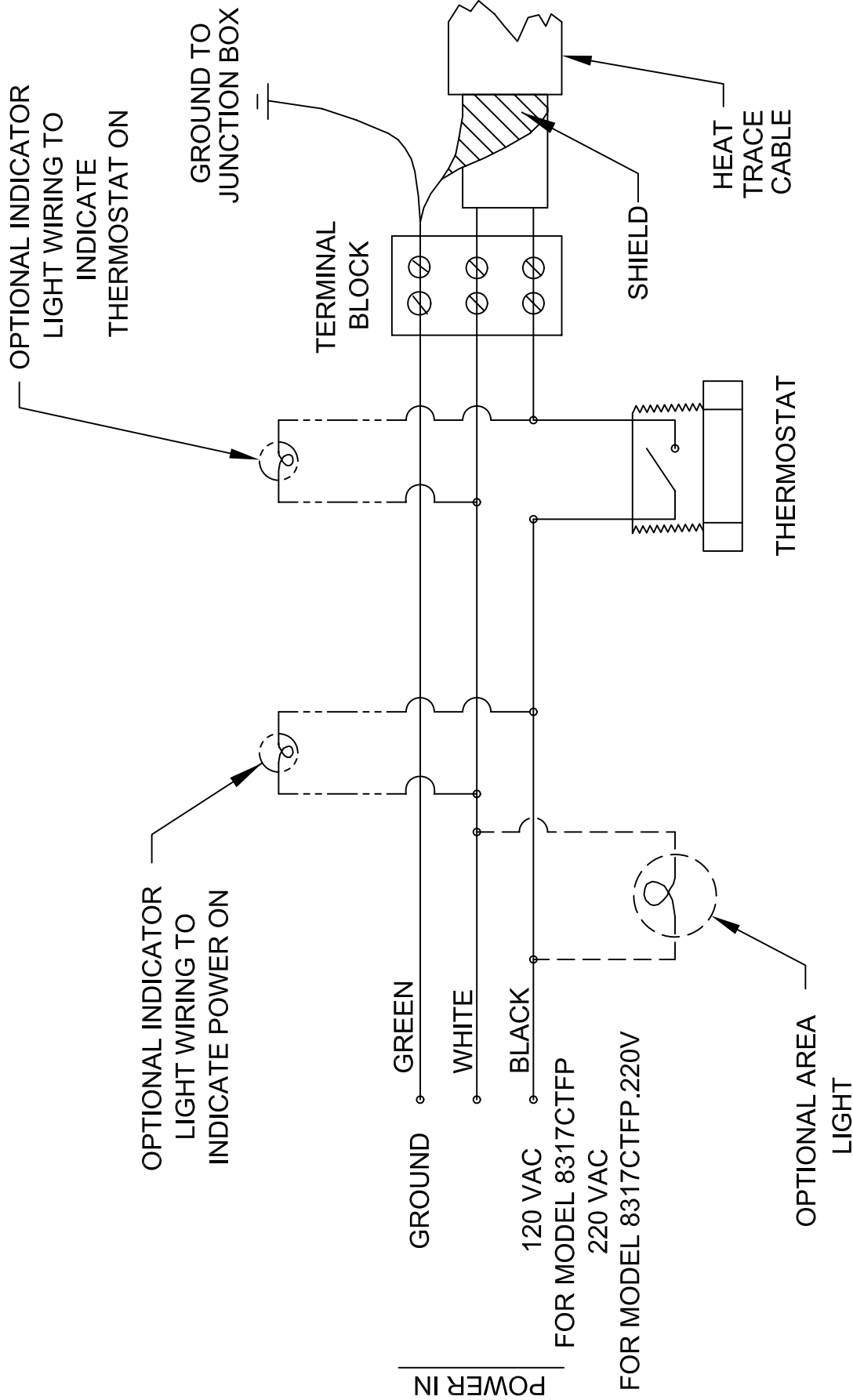

ELECTRICAL SCHEMATIC

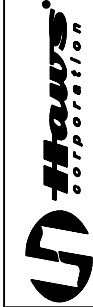

INFO FAX : 1-888-FAX-HAWS (1-888-329-4297)
 1455 Kleppe Ln, Sparks NV, 89431
 Phone: 775-359-4712 Fax: 775-359-7424
 Haws Ag, Bachweg 3, CH-3401 Burgdorf, Switzerland
 Haws Mfg Pte Ltd, 74 Sungai Kadut Loop, Singapore 729531
 e-mail: haws@hawsco.com website: www.hawsco.com

EQ. NO.	REVISED PER	BY	MODEL(S)
000000	ECN: 4173	HM	8317CTFP(120V)/8317CTFP.220V
DATE:	DATE:	DATE:	INFO. FAX. DOC. #:
03/29/05			2831778
APPROVED:	DATE:	SCALE:	1:10
		DRAWING TYPE:	INSTALLATION/FABRACK
		DRAWING NUMBER:	15201A00
		SIZE:	A
		SHEET:	2 OF 2