

SPEAKMAN COMPANY

SE-568 Installation, Maintenance & Operation Instructions

EYESAVER® EYEWASH

DESCRIPTION

Wall mounted barrier free eyewash with stainless steel bowl with a wrap around stainless steel skirt to hide supply piping. Unit includes dual aerated spray heads with automatic flow controls, and flip top dust covers. Unit is designed for ADA accessibility.

SPECIFICATIONS

BOWL: 300 Series Stainless Steel.
SKIRT: Stainless Steel
SPRAY HEADS: (2) Aerated Yellow ABS Plastic Spray Outlet, Sprayface, and Dust Cover.
VALVE: 1/2" NPT Female Brass, Chrome-Plated.
ACTIVATOR: Stainless Steel Push Handle.
INLET: 1/2" NPT Female.
SHIPPING WEIGHT: 10.4 lbs.
EMERGENCY SIGN: 7-7/8" x 7-7/8" Plastic Wall Sign.

OPTIONS

◇ PT (1-1/4" P-Trap)	◇ SSBV2 (1/2" Stainless Steel Valve)
◇ VPL (Vapor Proof Light)	◇ ILS (In line Strainer)

INSTALLATION

Review drawing (as shown on other side) to assure proper installation. The unit should be mounted to a structural member that will ensure structural rigidity (*see mounting hole dimensions in VIEW A-A*). Use appropriate wall anchors and be sure the unit is level to ensure proper flow pattern, and to avoid unnecessary water spillage. Connect a water supply to the unit (use pipe sealant on all joints) that is a 1/2" minimum uninterrupted source of potable water. Failure to use potable water can result in emergency units producing impure or contaminated water causing possible further injury. The drain tailpiece or waste is supplied with 1-1/2-16 UN external thread, and a 1-1/4-24 UNS internal thread. The drain or waste should be connected to an adequate drain in compliance with local plumbing codes.

OPERATION

The eye/face wash is activated by pushing the push handle back 90°. The unit will continue to discharge water until the push handle is manually pulled back to the off position.

TESTING PROGRAM

The American National Standards Institute (ANSI) states that all safety emergency equipment shall be activated on a weekly basis to flush the line and verify proper operation. Speakman Company furnishes a testing record tag (91-0635) with each unit. On this tag the date of inspection and the inspectors initials should be noted.

MAINTENANCE

Should you need parts to repair this unit, please reference the parts list below for correct part numbers. Before any maintenance is done *be sure to shut the water supply off.*

WARNING: *Use only genuine Speakman parts when repairing or replacing components. To order parts call 1-800-537-2107.*

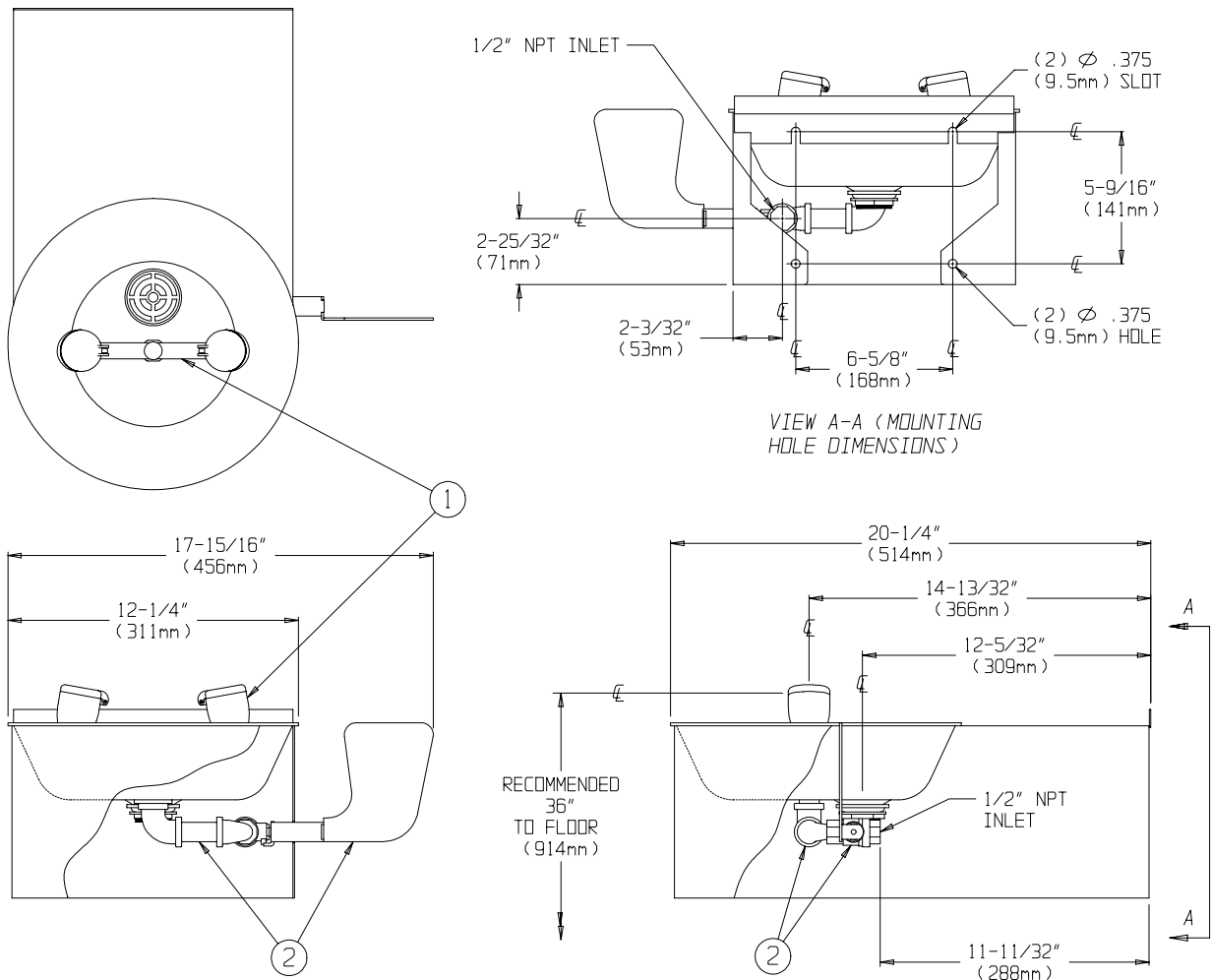

SE-568 REPLACEMENT/REPAIR PARTS

<u>ITEM</u>	<u>PART/GROUP #</u>	<u>DESCRIPTION</u>
1	RPG05-0714	Bullhorn & Spray Head Assembly
2	RPG20-1971	Valve, Handle & Supply Pipe Assembly

FLOW DATA

EYE/FACE WASH:

FLOW PRESSURE PSI (BAR)	30 (2.07)
FLOW RATE GPM (LPM)	3.82 (15)

Note: All units meet existing ANSI Z358.1 1998 Standards and OSHA Rules. Product improvements may cause specification and dimensional changes without notice.

NOTE: This unit should be connected to an uninterrupted source of potable water, with a minimum flowing pressure of 30 PSI and a maximum static pressure of 125 PSI.

SPEAKMAN®

PO Box 191 Wilmington, DE 19899

Phone: 800-537-2107 Fax: 800-977-2747

Visit us on the web at www.speakmancompany.com