

- Complies with American National Standard Z358.1-2004
- Galvanized Steel Protected with BRADTECT™ Safety Yellow Coating or All Stainless Steel
- Universal Identification Sign and Inspection Tag Included
- Full, One-Year Warranty
- Patent Pending



## Specifications

Combination Drench Shower and Eye/Face Wash Unit saves space and fits easily into any work environment. Shower valve operates quickly by a pull rod with a triangular handle. Shower provides a superior washdown with a more even spray pattern. Eye/face wash operated by a large, highly visible push handle. Safe, steady water flow under varying water supply conditions from 30–90 PSI is assured by integral flow control in the sprayhead assembly. NOTE: The ANSI Z358.1 standard requires an uninterrupted supply of flushing fluid at a minimum 30 PSI flowing pressure.

### cUPC Approved:

S19-310FW and S19-310SSJP are certified to comply with the requirements of the Uniform Plumbing Code and the National Plumbing Code of Canada by the International Association of Plumbing and Mechanical Officials (IAPMO).

## Standard Equipment

### SpinTec™ Showerhead

Standard showerhead is 3.1" (78.7mm) diameter highly visible yellow impact-resistant plastic (Model S19-310FW). High performance corrosion-resistant stainless steel showerhead with hexagonal profile measures 1-9/16" (40mm) point-to-point (Model S19-310SSJP). SpinTec drench showerhead features integral 23 GPM flow control, conserving water and helping to accurately size your tepid water system.

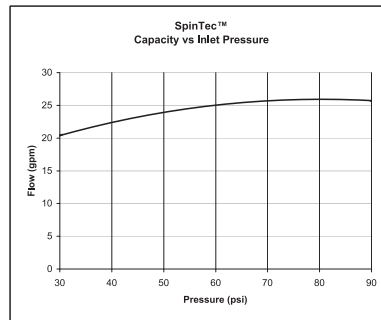

### Eyewash Bowl

10" (254mm) diameter yellow impact-resistant plastic or 10-3/4" (273mm) diameter corrosion-resistant stainless steel.

### Standard Sprayhead Assembly

Twin perforated-disc eye/face wash heads with protective pop-off sprayhead covers, operated by a large, highly visible push handle. Safe, steady water flow under varying water supply conditions from 30–90 PSI is assured by integral flow control in the sprayhead assembly. NOTE: The ANSI Z358.1 standard requires an uninterrupted supply of flushing fluid at a minimum 30 PSI flowing pressure.

### Shower Valve

Chrome-plated brass 1" NPT stay-open ball valve. Operated by a stainless steel pull rod with triangular handle. S19-310SSJP is all stainless steel.

### Eyewash Valve

Chrome-plated brass 1/2" NPT stay-open ball valve hand operated by highly visible safety yellow PVC push handle (S19-310FW). All-stainless steel 1/2" NPT stay-open ball valve hand operated by a stainless steel push handle (S19-310SSJP).

### Pipe and Fittings

1-1/4" galvanized steel with BRADTECT™ safety yellow coating (S19-310FW) All-stainless steel (S19-310SSJP).

### Water Supply

1-1/4" NPT.

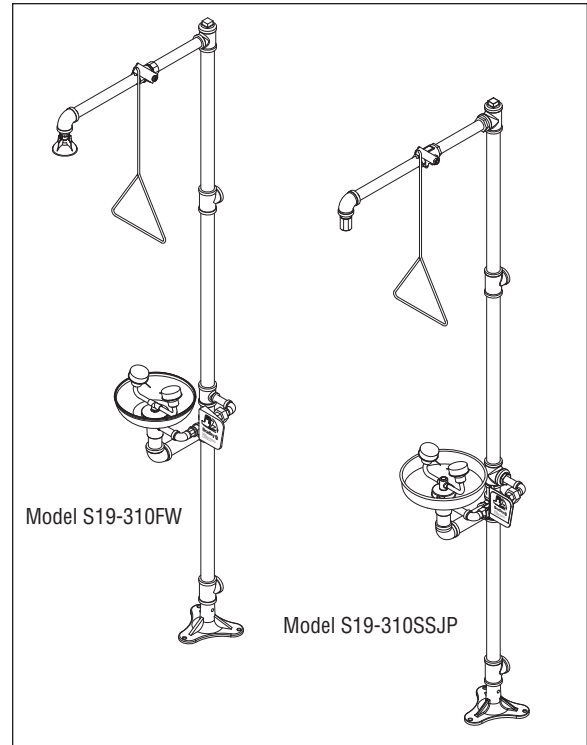

Local codes may require the installation of a backflow prevention valve to complete proper installation. Compliance with local codes is the responsibility of the installer. Valve must be tested annually to verify that it is functioning properly. Backflow prevention valves are not included with the fixture and may be supplied by the contractor or purchased from Bradley Corporation.

Model	Description
<input type="checkbox"/> S19-310FW	Drench Shower and Eye/Face Wash - <b>Plastic Showerhead and Bowl</b>
<input type="checkbox"/> S19-310SSJP	Drench Shower and Eye/Face Wash - <b>All Stainless Steel except Sprayheads</b>
<input type="checkbox"/> S19-2100	Navigator EFX25 - Emergency Thermostatic Mixing Valve

**Recommended Option:**

Navigator S19-2100 EFX25  
Emergency Thermostatic Mixing Valve

**NAVIGATOR**

Satisfies ANSI Z358.1-2004 tepid water requirements.

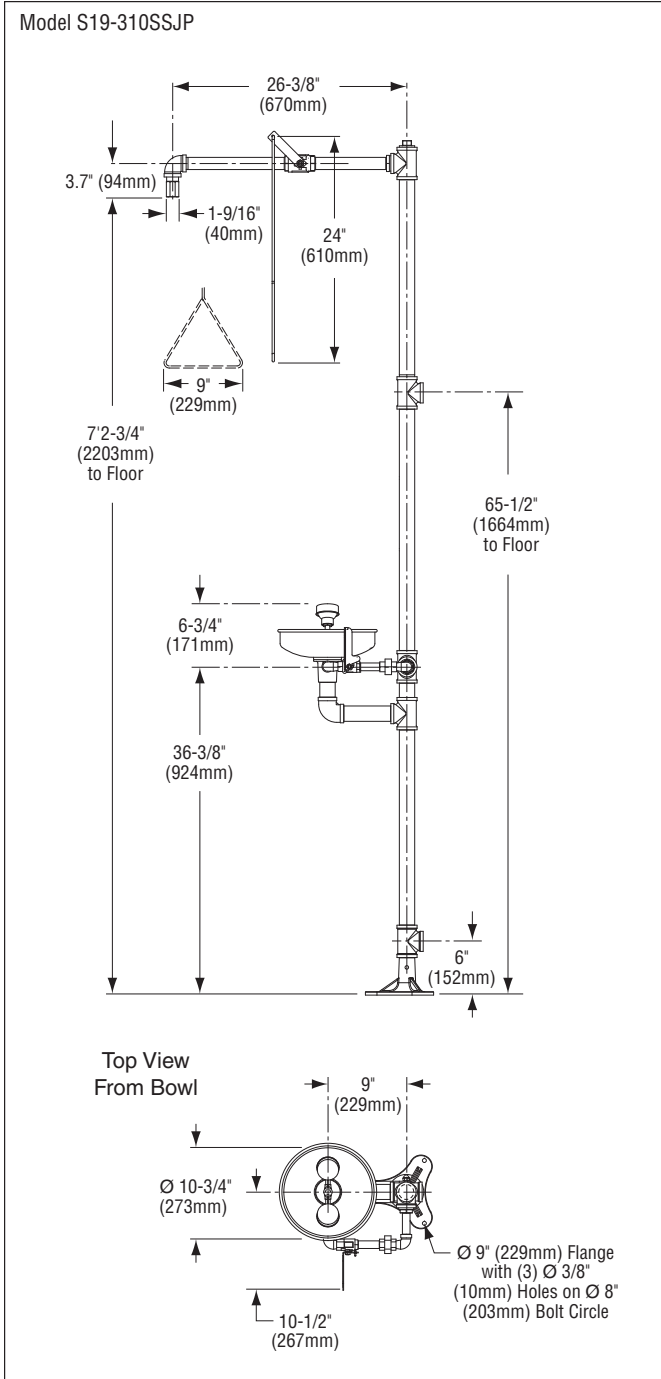
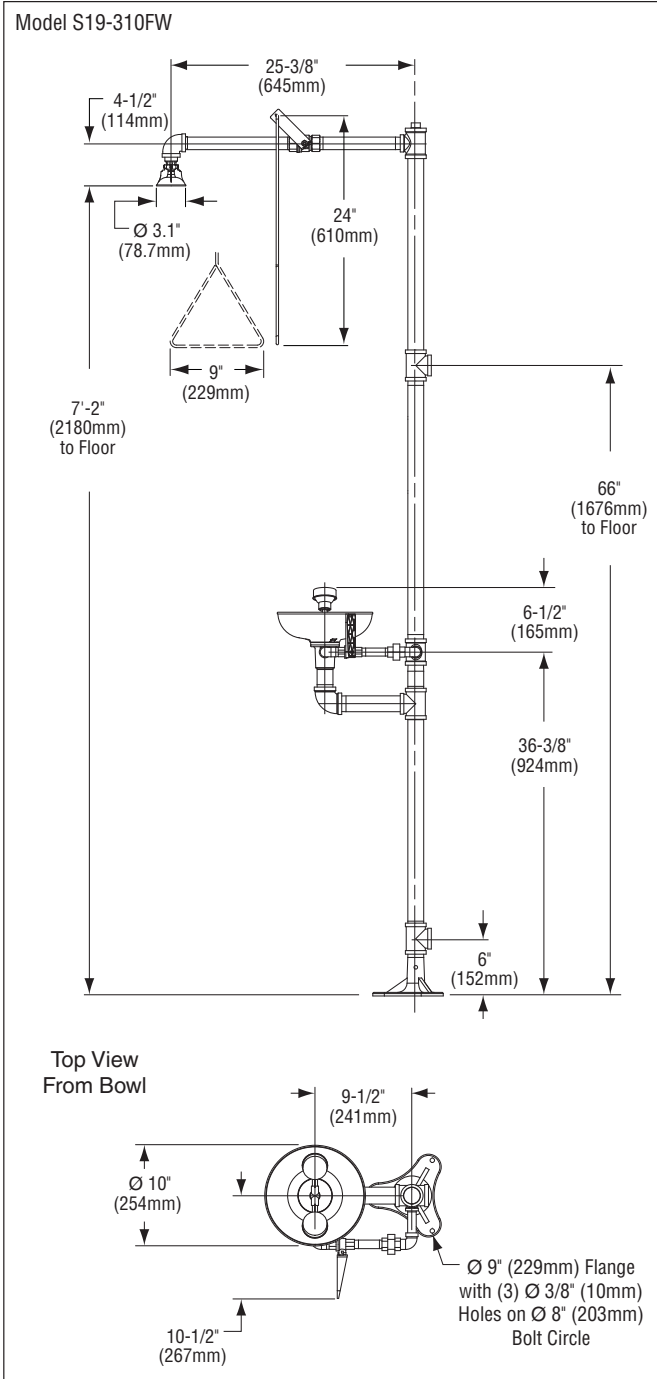

All dimensions assume standard thread engagement. Variations in manufacturing allow for +/- 1/8" (3mm) per threaded joint. To find the tolerance of a dimension, add the number of thread joints in between a dimension and multiply it by 1/8" (3mm).