

Stainless Steel Hand-Held Hose Spray

Model S19-430D

- Complies with American National Standard Z358.1-2004
- Laboratory Spray Valve
- Flexible Stainless Steel Hose
- Full, One-Year Warranty

Specifications

Stainless steel hose is flexible. Perforated sprayhead provides soft spray for cleansing eyes and face. Handle stays open once it is squeezed. Wall bracket included.

UPC and cUPC Approved:

The Emergency Fixtures are certified to comply with the requirements of the Uniform Plumbing Code and the National Plumbing Code of Canada by the International Association of Plumbing and Mechanical Officials (IAPMO).

Construction

6' (1829mm) stainless steel hose has 3/8" IPS male thread. Burst strength is 750 PSI.

Standard Equipment

Sprayhead

Perforated sprayhead is ABS plastic and provides soft spray for cleansing eyes and face. Includes protective sprayhead cover. Integral flow control assures safe, steady flow under varying water supply conditions.

Valve

Chrome plated brass with extended handle stays open until manually closed.

Drench Hose

6' (1829mm) stainless steel hose has 3/8" IPS male thread. Burst strength is 750 PSI.

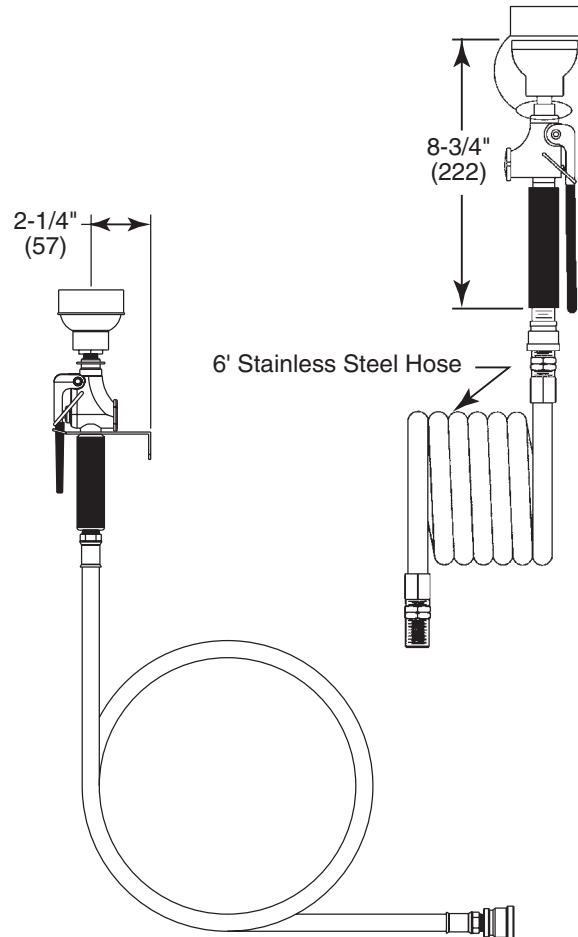

MODEL

Model No.	Description
<input type="checkbox"/> S19-430D	Stainless Steel Hand-Held Hose Spray

IMPORTANT NOTES:

- Drench hoses must provide a controlled flushing fluid flow that is both tepid and non-injurious to the user per ANSI Z358.1-2004. Refer to ANSI Z358.1-2004 for complete regulatory information regarding the performance, installation, maintenance, and training requirements for drench hoses.
- Installer to supply backflow prevention as required by UPC, IPC and/or local plumbing codes. Contact Bradley or visit www.bradleycorp.com for available options.