



- G5014** Eyewash/Drench Hose Unit, Wall Mounted
- G5014BP** Eyewash/Drench Hose Unit, Wall Mounted, with Backflow Preventer



APPLICATION: Dual purpose eyewash/drench hose for wall mounting. Unit meets the provisions of ANSI Z358.1 - 2004 as both an eyewash and a drench hose. Unit may be left in the mounting bracket for use as a fixed eyewash, leaving user's hands free. Alternatively, unit may be removed for use as a drench hose to rinse any part of user's eyes, face or body.

SPRAY HEAD ASSEMBLY: Two GS-Plus™ spray heads mounted side-by-side. Each head has a "flip top" dust cover, internal flow control and filter to remove impurities from the water flow.

VALVE: 1/2" IPS chrome plated brass stay-open ball valve. Valve is US-made with chrome plated brass ball and Teflon® seals.

HOSE: 12' reinforced nylon retractable coiled hose. 180 PSI maximum working pressure.

MOUNTING: Bracket with spring clips to hold unit on wall. Clips assure that spray heads face forward at all times.

BACKFLOW PREVENTER: In-line dual check backflow preventer installed on inlet of hose (G5014BP only). *Note: Check with code authority for compliance with local plumbing code.*

SUPPLY: 3/8" NPT female inlet.

SIGN: ANSI-compliant identification sign.

QUALITY ASSURANCE: Unit is completely assembled and water tested prior to shipment.

Available Options

- DC** Stainless steel dust cover for each spray head.
- VB** In-line vacuum breaker for installation between valve and spray head.
- TMV** G3600 thermostatic mixing valve precisely blends hot and cold water to deliver warm (tepid) water as provided by ANSI Z358.1 - 2004. Refer to "Tempering Units" section for complete technical and product selection information.





- **G5014** Eyewash/Drench Hose Unit, Wall Mounted
- **G5014BP** Eyewash/Drench Hose Unit, Wall Mounted, with Backflow Preventer

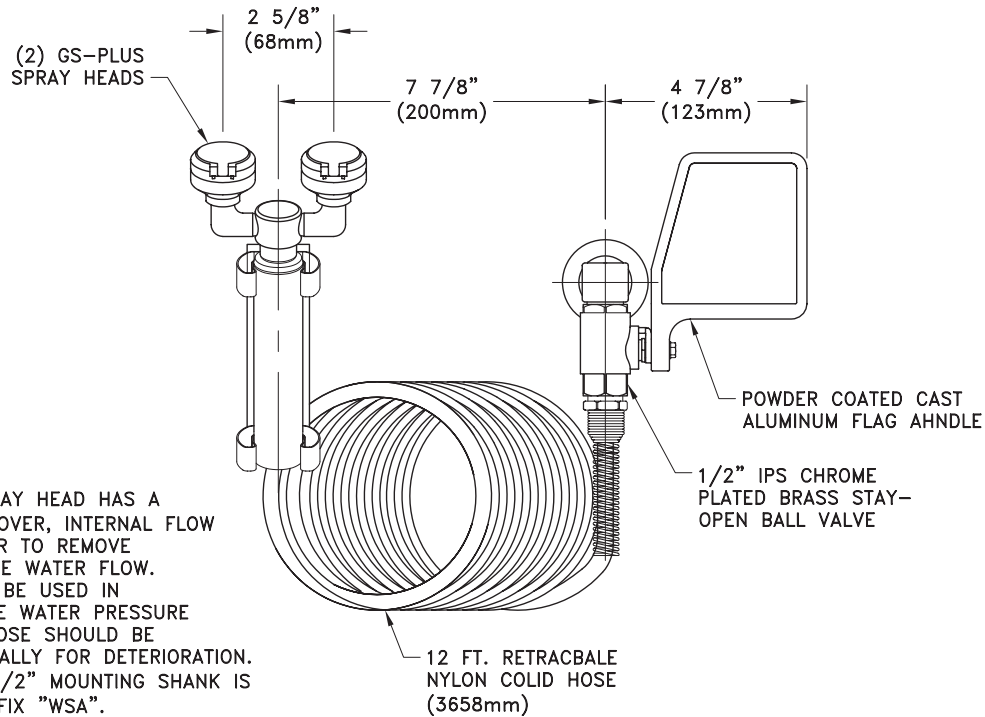
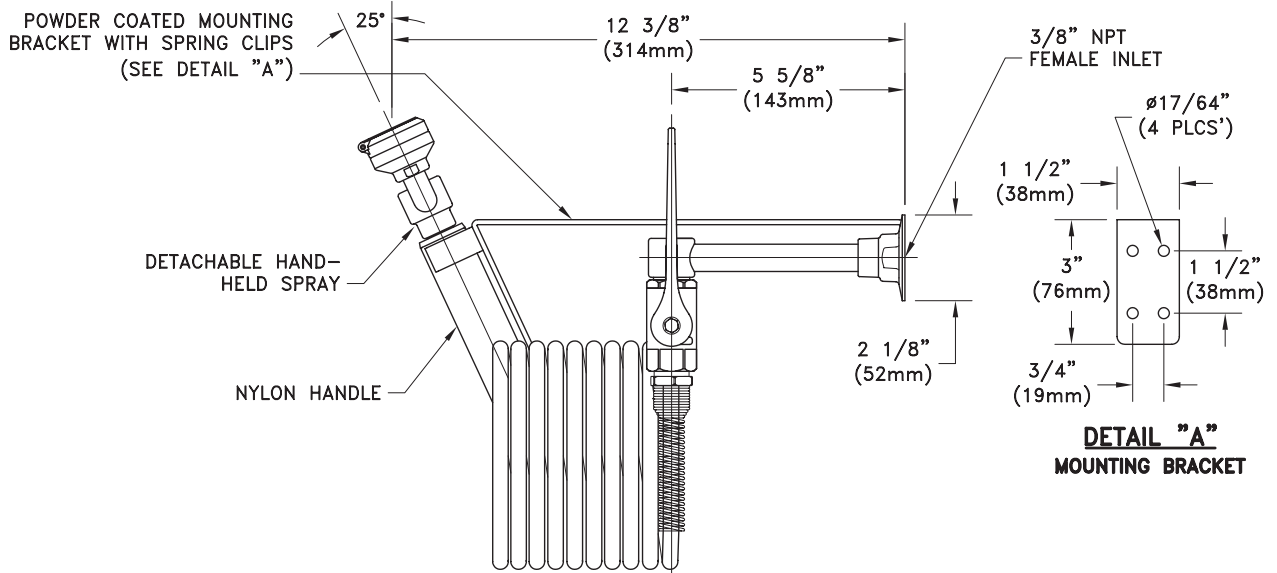

NOTES:

1. EACH GS-PLUS SPRAY HEAD HAS A "FLIP-TOP" DUST COVER, INTERNAL FLOW CONTROL AND FILTER TO REMOVE IMPURITIES FROM THE WATER FLOW.
2. HOSE SHOULD NOT BE USED IN APPLICATIONS WHERE WATER PRESSURE EXCEEDS 90 PSI. HOSE SHOULD BE INSPECTED PERIODICALLY FOR DETERIORATION.
3. IF 3/8" IPS X 2-1/2" MOUNTING SHANK IS REQUIRED, ADD SUFFIX "WSA".

THIS SPACE FOR ARCHITECT/ENGINEER APPROVAL

Due to continuing product improvement, the information contained in this document is subject to change without notice. All dimensions are ± 1/4" (6mm). rev. 0308

Sign Included

