

# SPEAKMAN®

## SE-925 DRENCH HOSE

### DESCRIPTION

The SE-925 wall mounted drench hose featuring stay open valve, single aerated spray with automatic flow control, 12' recoiling hose and flip-top dust covers.

### SPECIFICATIONS

**Spray Head:** Yellow plastic spray outlet with flip-top dust cap and an automatic flow control

**Valve:** 3/8" NPT female brass, chrome-plated

**Activator:** Brass, chrome-plated squeeze handle

**Hose:** 12' recoiling hose

**Flange:** Brass, chrome-plated

**Inlet:** 3/8" NPT male, swivel connection

**Performance:** 1.6 gpm @ 30 psi

**Compliance:** ANSI Z358.1

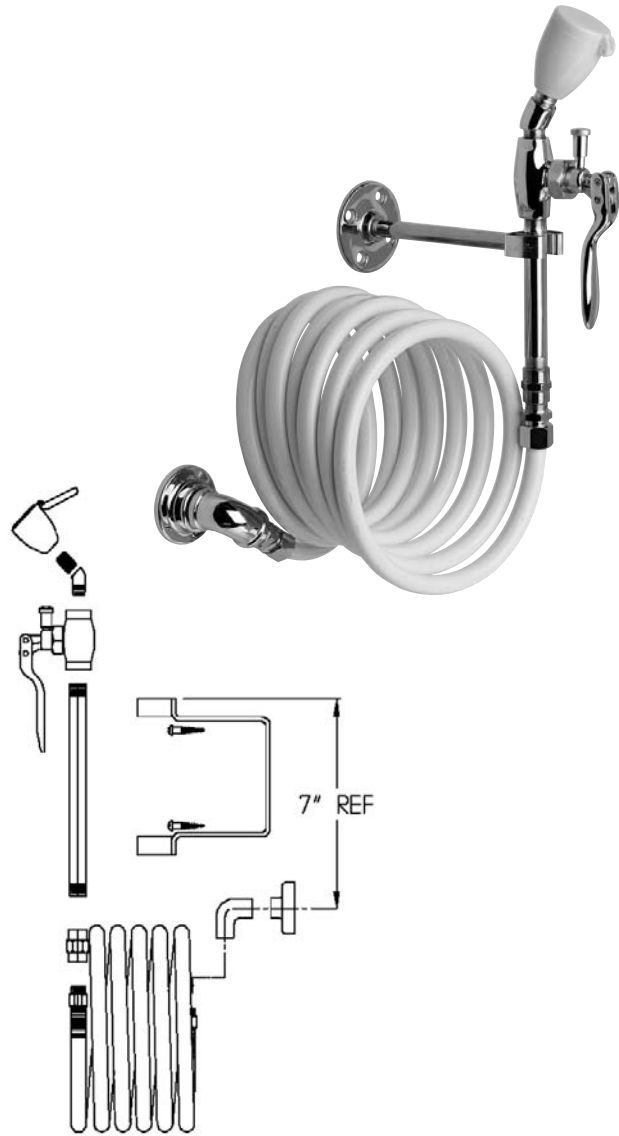

### OPTION

VB Vacuum breaker

Job Name _____
Location _____
Architect/Engineer _____
Sales Representative _____
Wholesaler _____
Date _____ Model # _____