



Freeze-Resistant Bi-Level Endura™ Steel Pedestal

Barrier-Free Fountain

MODEL 4720 FR



This fountain is certified to
NSF/ANSI 61.

GENERAL

Pedestal, Endura™ steel fountain with textured powder coat finish and E-Coat immersion for year-round beauty with minimum maintenance. The E-Coat immersion process coats the outside and inside of the fountain for the ultimate in corrosion protection. Contour formed stainless steel basins with rounded corners and edges reduces splatter, insures proper drainage and prevents standing waste water. Designed to be easily accessible to both physically challenged and able-bodied individuals. Ideally suited for installation in public areas. Model meets state and federal requirements as defined by the Americans with Disabilities Act.

FREEZE-RESISTANT VALVE SYSTEM

Freeze-resistant valve designed for ground installation 18" below the frost line.

BUBBLER

Exclusive one-piece, vandal-resistant, chrome-plated two-stream mound-building bubbler with non-removable anti-squirt feature and integral hood insures a satisfying drink of water.

PUSHBUTTON ACTUATION MECHANISM

Self-closing, vandal-resistant pushbutton does not require grasping or twisting.

AUTOMATIC STREAM HEIGHT REGULATOR

Self-closing assembly is located inside unit to prevent tampering. Unit resists corrosion and liming. A constant stream height is automatically maintained under line pressures that vary from 20 to 105 psi.

INLET STRAINER

Easily cleaned in-line strainer screen traps particles of 140 microns or larger before they enter the waterway.

WATER INLET

3/8" female NPT fitting.

DRAIN OUTLET

1-1/4" tube outlet. Drain requirements are detailed in owner's manual.

ACCESS PANEL

Manufactured of heavy-gauge steel with vandal-resistant screws. Provides access for easy hook-up of all plumbing connections.

SUGGESTED SPECIFICATIONS

Fountains shall include pushbuttons on the front and back. Shall include contour-formed basins to eliminate splashing and standing water, and shall have rounded corners and edges. Projectors shall be two-stream, mound-building type with integral hood guard and anti-squirt feature. Fountain shall comply with ANSI 117.1 and ADA for visual and motion disabilities. The manufacturer shall certify the unit to meet the requirements of NSF/ANSI 61, and the Safe Drinking Water Act.

Note: Continued product improvement makes specifications subject to change without notice. See Halsey Taylor website for most current spec sheet.

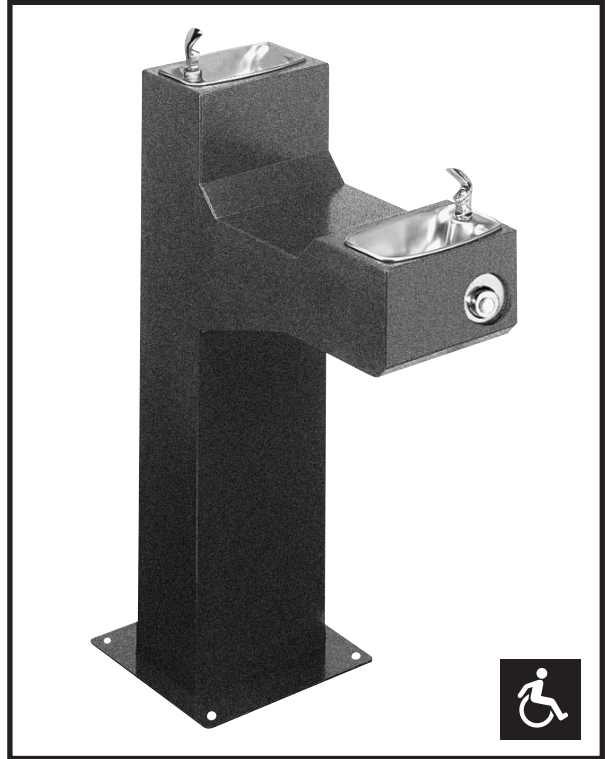

Standard Finish is Evergreen textured powder-coat Endura II™

Each 4720 FR consists of 2 cartons of the following:

Fountain

Freeze-Resistant Valve System

Service stop not included.

Shipping weight: 119 lbs.

JOB NAME:	_____
_____	_____
ENGINEER/CONTRACTOR NAME:	_____
_____	_____
APPROVAL:	_____
DATE:	_____



4720 FR

Freeze-Resistant Barrier-Free Steel Endura™ Pedestal Fountain with Twin Receptors

(CONTINUED)

MOUNTING INSTRUCTIONS and PLUMBING CONNECTIONS

Site and drainage excavation is required for fountain installation. Refer to owner's manual for site preparation details. Provide solid, well-drained surface to mount pedestal fountain (concrete pad recommended). (4) 1/2" anchor bolts (not included) should be attached firmly to mounting surface in order to secure fountain. Refer to rough-in diagram and be sure to allow an opening for the freeze-resistant valve in the ground as shown in the installation instructions that accompany the fountain. Refer to local codes for any additional requirements.

NOTE: Fountain is not furnished with service valve. Assemble fountain to prepared site and mounting pad.

Position pedestal over plumbing and secure base to anchor bolts. Remove access panels and connect supply and water lines. Turn on water supply and check for leaks. Refer to owner's manual for detailed instructions.

OPERATING PRESSURES:

Supply water - 105 psi maximum

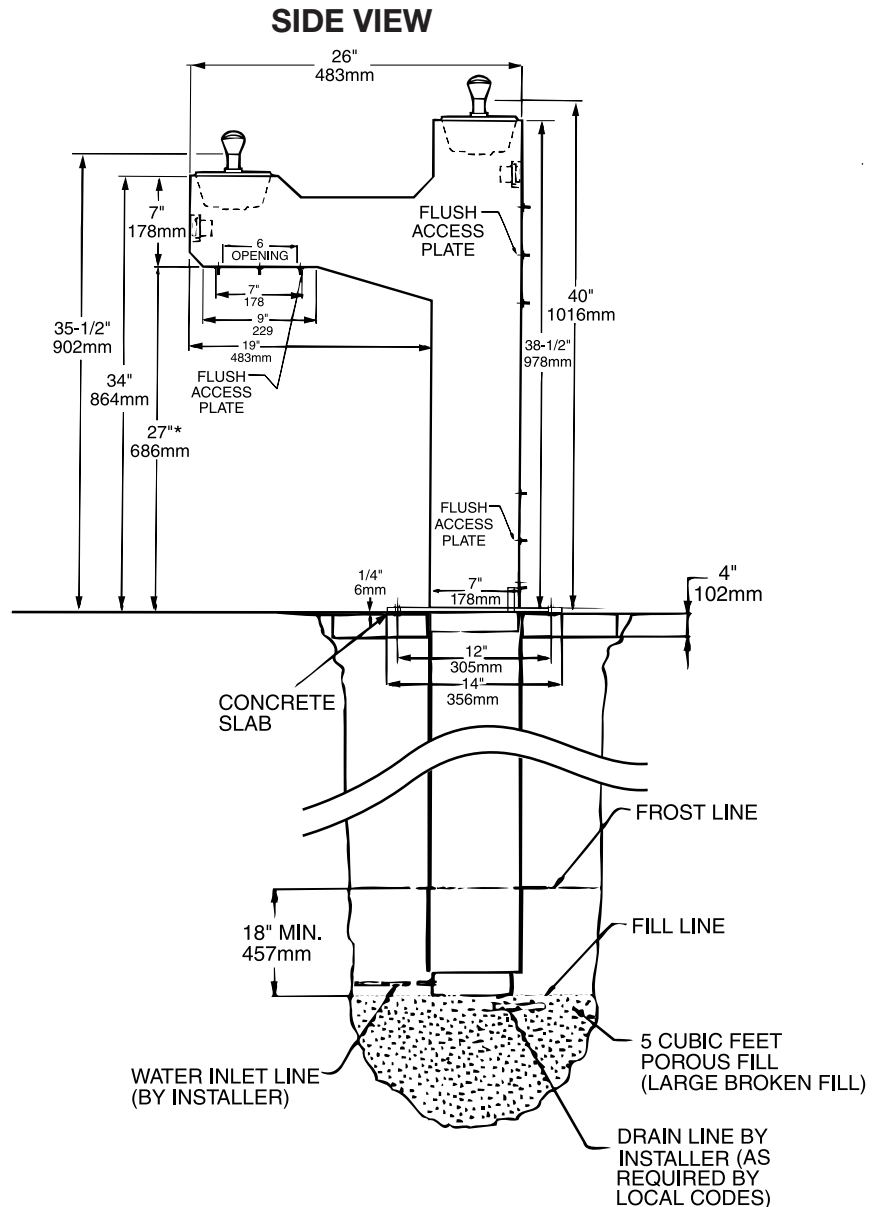
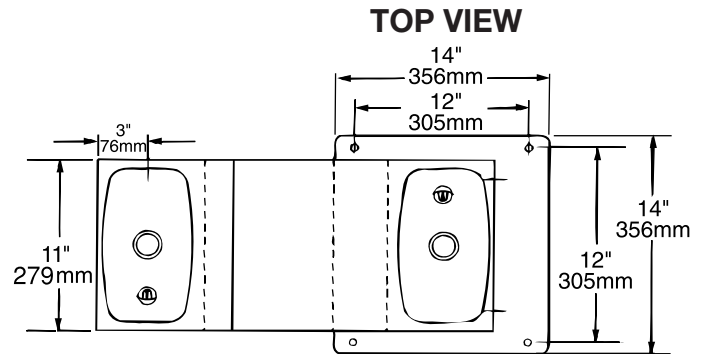

BACK VIEW

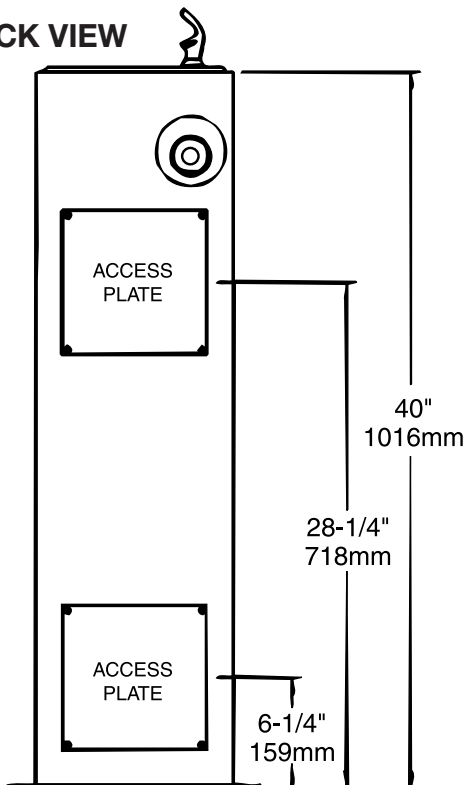

GROUND ROUGH-IN DETAIL
OF FREEZE-RESISTANT SYSTEM

Halsey Taylor®