

3380FR

Pedestal Mounted Drinking Fountain



FEATURES & BENEFITS

Construction

Heavy-duty 11 gauge galvanized steel with a green powder-coat finish incorporates a rounded tube design for an aesthetically pleasing design, and a vandal-resistant access plate for added peace of mind.

All-Weather Capabilities

Fully engineered system with the pneumatic operated freeze-resistant valve installed below frost line to drain water to non-freezing depth allowing fountain to function year-round. Assembly can be lifted to surface and lowered back into casing for easy maintenance without disturbing the fountain.

Bubbler head

Polished chrome-plated brass bubbler head with an integral basin shank and inserted roll pin adds vandal resistance strength to the design, and the shielded angled stream orifice produces a steady sanitary source of water.

Finish

Beautiful #4 satin stainless steel finish basin can be easily cleaned and maintained while also resisting corrosion.

Push Button

Polished chrome-plated push-button requires less than 5 lbs. to activate.



OPTIONS

- Valve Box: Model 6625, ground box with lid, used with freeze-resistant valve models 6518FR and 6518.2FR.
- Premier Colors: Nine powder-coated colors, (green, silver, red, blue, black, brown, orange, yellow and white), available for an additional charge.

SPECIFICATIONS

Model 3380FR barrier-free freeze-resistant pedestal drinking fountain shall include an 18 gauge Type 304 Stainless Steel satin finish basin with integral swirl design, polished chrome-plated brass push-button, polished chrome-plated brass vandal-resistant bubbler head, chrome-plated brass vandal-resistant waste strainer, 11 gauge galvanized substrate steel pedestal with green powder-coating, integral mounting plate, and 1-1/2" O.D. tailpiece.

APPLICATIONS

Perfect for either public or private outdoor settings, the 3380FR is a great fit in areas where aesthetics are important to the overall appeal of the architecture. Suitable in areas where weather conditions exist, this series stands strong as a nice addition to any community. Powder-coated finish helps to maintain the fountain's overall appeal so it remains looking as new as it did when it was installed. This type of pedestal drinking fountain may also be placed in a variety of settings such as: parks, schools, and other outdoor environments around office buildings where the temperature may drop into freezing conditions.

Model meets all current Federal Regulations for the disabled including those in the Americans with Disabilities Act. Haws manufactures drinking fountains, electric water coolers and electric drinking fountains to be lead-free by all known definitions including ANSI/NSF Standard 61, Section 9, California Proposition 65, and the Federal Safe Drinking Water Act.



3380FR/3380GFR WITH 6518FR

(SEE SHEET 2 OF 3 FOR 6519FR INSTALLATION)

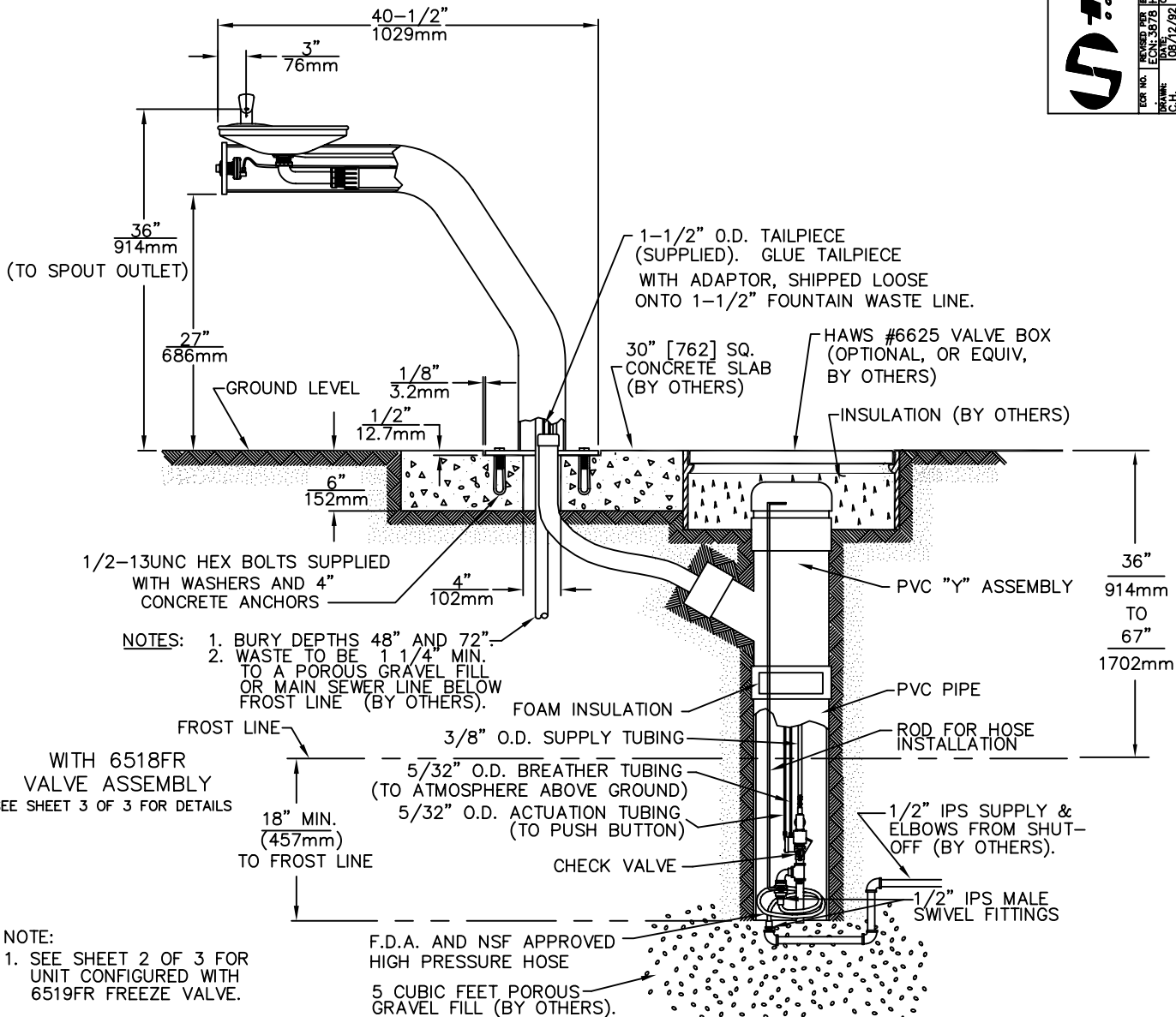
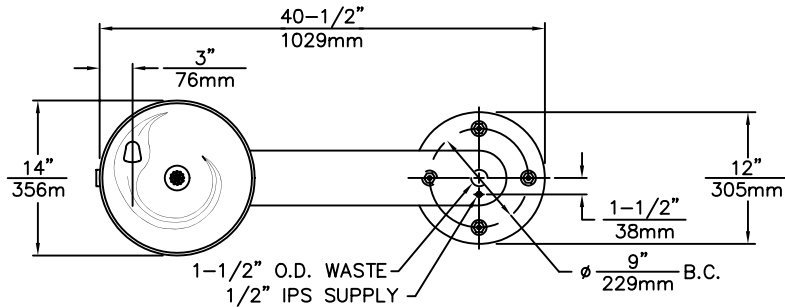

- 1/2-13UNC HEX BOLTS SUPPLIED WITH WASHERS AND 4" CONCRETE ANCHORS
- NOTES: 1. BURY DEPTHS 48" AND 72"
2. WASTE TO BE 1 1/4" MIN. TO A POROUS GRAVEL FILL OR MAIN SEWER LINE BELOW FROST LINE (BY OTHERS).

Haws Corporation

INFO FAX : 1-888-FAX-HAWS (1-888-329-4297)
1455 Kleppe Ln. Sparks, NV. 89431
Phone: 775-359-4712 FAX: 775-359-7424
Haws Ag. Buehler 3. CH. 3401. Burgdorf, Switzerland
Haws Mfg. Pte. Ltd. 74. Sungai Kadut Loop Singapore 729531
e-mail: Haws@hawsco.com website: www.hawsco.com

MODEL(S): 3380FR / 3380GFR / 3380.6519FR
DRAWING NUMBER: 10289A00
SCALE: 1:17 DRAWING TYPE: INSTALLATION/PANBACK
REV. 1 OF 3

THIS DOCUMENT IS TRUE AND CORRECT AT TIME OF PUBLICATION. CONTINUED PRODUCT IMPROVEMENTS MAKE SPECIFICATIONS AND MEASUREMENTS SUBJECT TO CHANGE WITHOUT NOTICE.

©2006 Haws Corporation - All Rights Reserved HAWS® and other trademarks used in these materials are the exclusive property of Haws Corporation.

3380FR/3380GFR WITH 6519FR
 (SEE SHEET 1 OF 3 FOR FOUNTAIN & 6518FR INSTALLATION)

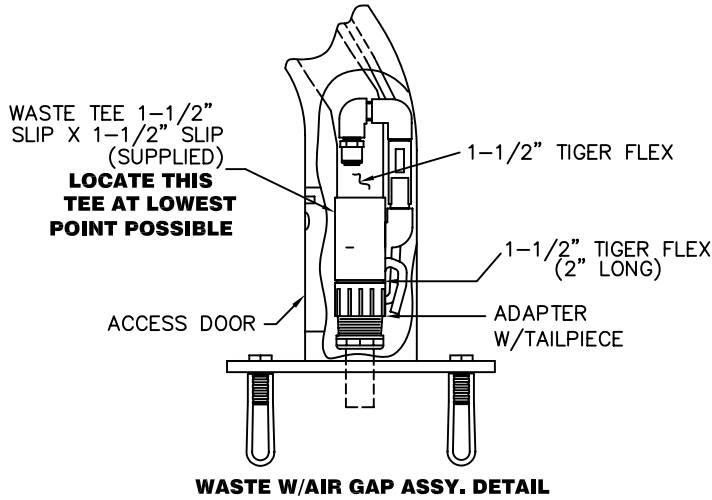

WASTE W/AIR GAP ASSY. DETAIL

WITH 6519FR VALVE ASSEMBLY

SEE SHEET 3 OF 3 FOR DETAILS

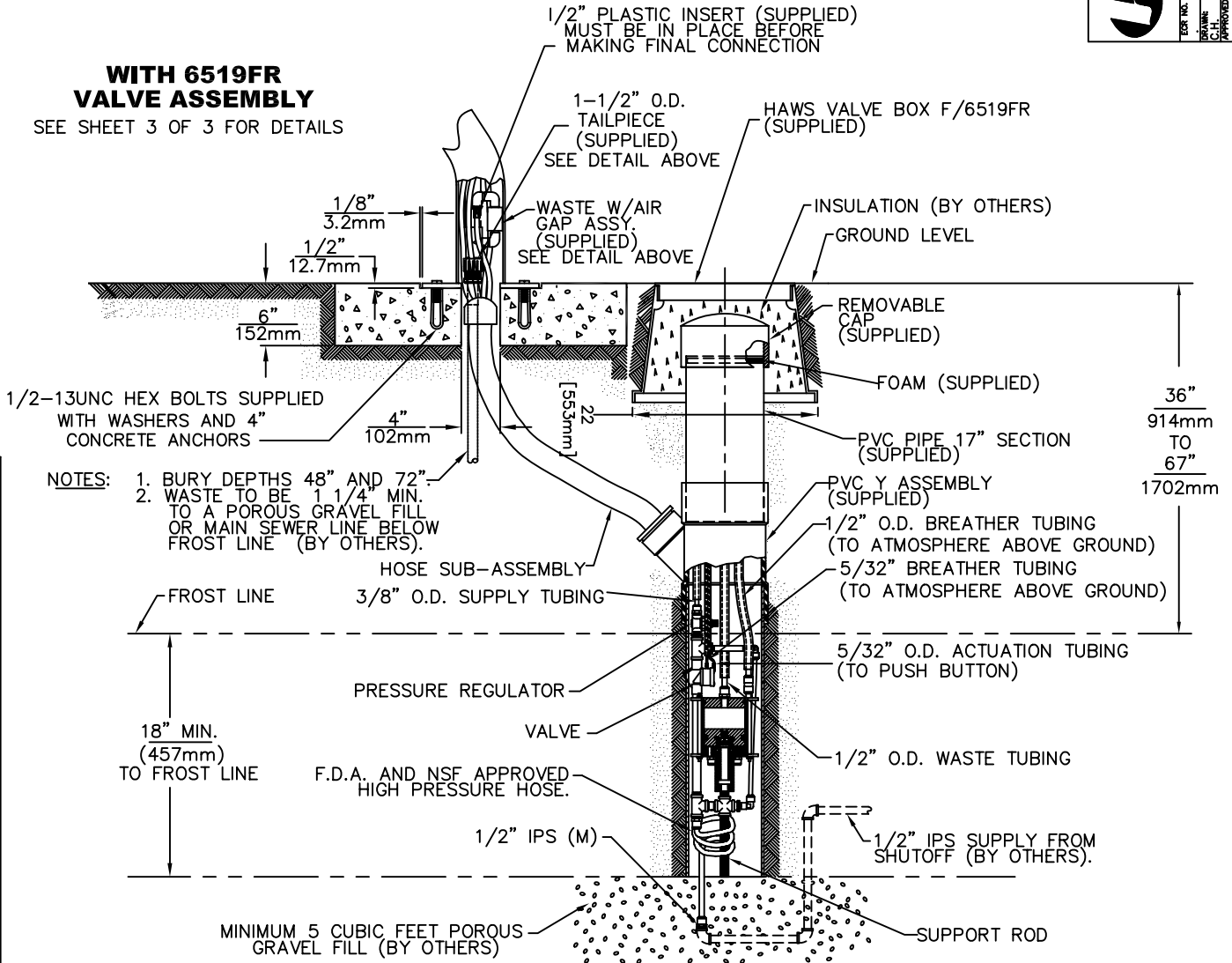

- NOTES:**
1. BURY DEPTHS 48" AND 72"
 2. WASTE TO BE 1 1/4" MIN. TO A POROUS GRAVEL FILL OR MAIN SEWER LINE BELOW FROST LINE (BY OTHERS).

Haws Corporation

INFO FAX : 1-888-FAX-HAWS (1-888-329-4297)
 1455 Kleppe Ln, Sparks NV, 89431
 Phone: 775-359-4712 Fax: 775-359-7424
 Haws Ag Bachweg 3 CH-3401 Burgdorf Switzerland
 Haws Mfg Pte Ltd 74 Sungei Kadut Loop Singapore 729531
 e-mail: Haws@hawsco.com website: www.hawsco.com

MODEL(S): 3380FR/3380GFR/3380 6519FR
 INFO FAX DOC # 2338037/23380437/23380651
 SCALE: 1/8" = 1'-0" DRAWING TYPE: INSTALLATION/DETAIL

REVISED FOR BETA 05/05/02
 DRAWN: DATE: 06/12/02
 APPROVED: C.H.

PART NUMBER: 002077370.D
 1029A00
 1st
 SIZE: A 1. SET: 2 OF 3

THIS DOCUMENT IS TRUE AND CORRECT AT TIME OF PUBLICATION. CONTINUED PRODUCT IMPROVEMENTS MAKE SPECIFICATIONS AND MEASUREMENTS SUBJECT TO CHANGE WITHOUT NOTICE.

©2006 Haws Corporation - All Rights Reserved HAWS® and other trademarks used in these materials are the exclusive property of Haws Corporation.

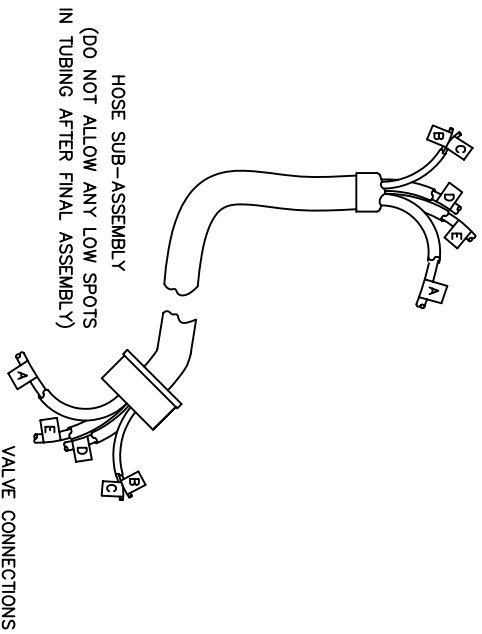

FOUNTAIN CONNECTIONS
(FOLLOW INSTRUCTIONS ON LABELS)

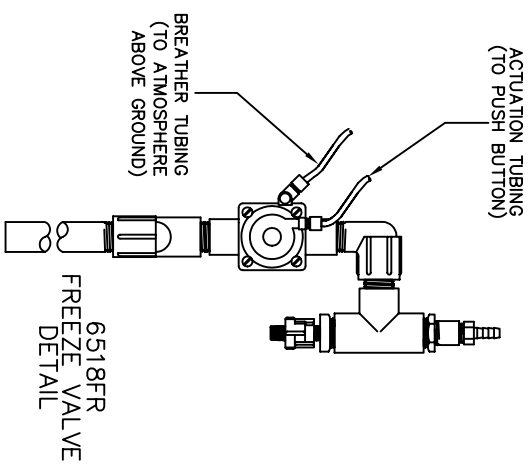

CAUTION: VALVE ASSEMBLY MUST BE KEPT VERTICAL AT ALL TIMES. USE TEMPORARY STAND PROVIDED UNTIL VALVE INSTALLATION IS FINALIZED.

6519FR FREEZE VALVE DETAIL
(3 WAY DIVIDER W/TUBING AT BASE NOT SHOWN FOR CLARITY)

BASE NOT SHOWN FOR CLARITY

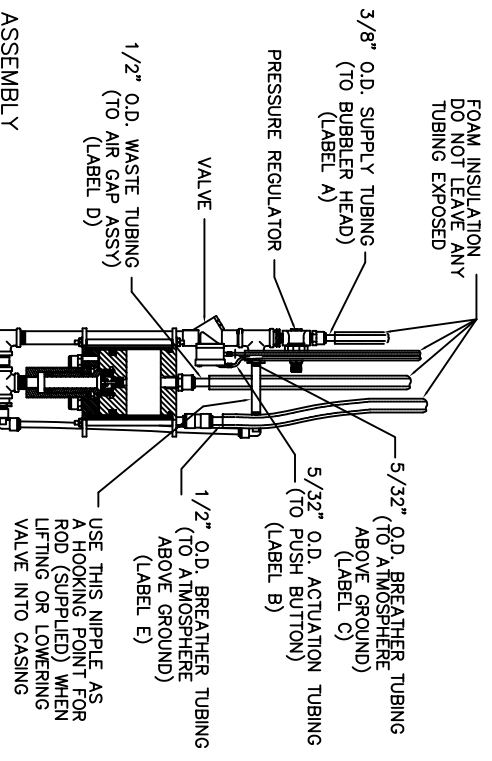

		<p>INFO FAX : 1-888-FAX-HAWS (1-888-329-4297)</p> <p>1455 Kiappa Ln, Sports NY, 89431 Phone: 775-359-4712 Fax: 775-359-7424 Haws Ag Buchweg 3 CH-3401 Burgdorf, Switzerland Haws Mfg Pte Ltd 74 Sungai Kodut Loop Singapore 729531 e-trail: Haws@hawsco.com website: www.hawsco.com</p>	
<p>REG. NO. 3380FR</p> <p>DATE 05/16/06</p> <p>APPROVER</p>	<p>REG. NO. 3380FR</p> <p>DATE 05/16/06</p> <p>APPROVER</p>	<p>MODEL(S): 3380FR/3380GFR/3380.6519FR</p> <p>INFO FAX DOC # 233803/23380437/23380651</p>	<p>REG. NO. 3380FR</p> <p>DATE 05/16/06</p> <p>APPROVER</p>



INSTALLATION, OPERATION & MAINTENANCE INSTRUCTIONS

1455 Kleppe Lane ♦ Sparks, NV 89431-6467 ♦ (775) 359-4712 ♦ Fax (775) 359-7424
HAWS AG ♦ Bachweg 3 ♦ CH-3401 Burgdorf ♦ Switzerland
Haws Mfg. Pte Lt. ♦ 2A Sungei Kadet Drive ♦ Singapore 729554
Avlis-Avenida Senador, Testonio Vilela ♦ 505 Jardim Aeroporto ♦ Itu, S.P. 13304-550 ♦ Brasil
E-mail: haws@hawsco.com ♦ website: www.hawsco.com

No. 2077370(11)

Model 3380FR/3380GFR/3380.6519FR Drinking Fountain

NOTE TO INSTALLER: Please leave this information with the Maintenance Department.

LIMITED WARRANTY

HAWS® warrants that all of its products are guaranteed against defective material or poor workmanship for a period of **one year from date of shipment**. HAWS liability under this warranty shall be discharged by furnishing without charge F.O.B. HAWS Factory any goods, or part thereof, which shall appear to the Company upon inspection to be of defective material or not of first class workmanship, provided that claim is made in writing to company within a reasonable period after receipt of the product. Where claims for defects are made, the defective part or parts shall be delivered to the Company, prepaid, for inspection. HAWS will not be liable for the cost of repairs, alterations or replacements, or for any expense connected therewith made by the owner or his agents, except upon written authority from HAWS, Sparks, Nevada. HAWS will not be liable for any damages caused by defective materials or poor workmanship, except for replacements, as provided above. Buyer agrees that Haws has made no other warranties either expressed or implied in addition to those above stated, except that of title with respect to any of the products or equipment sold hereunder and that HAWS shall not be liable for general, special, or consequential damages claimed to arise under the contract of sale. The drinking fountain manufactured by HAWS is warranted to function if installation and maintenance instructions provided are adhered to. The units also must be used for the purpose for which they were intended.

NO OTHER WARRANTIES EXPRESSED OR IMPLIED ARE AUTHORIZED, PROVIDED OR GIVEN BY HAWS.

SHOULD YOU EXPERIENCE DIFFICULTY WITH THE INSTALLATION OF THIS MODEL, PLEASE CALL:

1-800-766-5612

FOR PARTS CALL:

1-800-758-9378

**(U.S.A. AND CANADA ONLY) MONDAY-THURSDAY: 6:00 A.M. – 4:00 P.M. PST
FRIDAY: 6:00 A.M – 1:00 P.M. PST**

RECOMMENDED TOOLS: Hack saw, pipe joint sealant, screwdriver, level, 12" adjustable wrench, 10" pipe wrench, 5/64" hex key wrench, 9/16", 1/2", 7/16" socket wrench or open end wrench.

LOCATION OF UNIT: The Model 3380FR/3380GFR Drinking Fountain is a wheelchair accessible drinking water facility. The height dimensions shown, meet current ADA requirements. When installing this unit, local, state or federal codes should be adhered to. If height other than shown is required, then dimensions must be adjusted accordingly.

SUPPLY LINE: The minimum recommended line size is 1/2"IPS. Flowing pressure is 30-90 psi (2-6 ATM) for Models 3121FR and 3121.6280FR. Flowing pressure for Model 3121.6519FR is 45-90 psi (3-6 ATM). Where sediment or mineral content is a problem, an inlet filter is recommended.

PLUMBING CONNECTIONS: Supply inlet is 1/2" IPS male. Waste outlet is 1-1/2"O.D. tailpiece.

MAINTENANCE: Refer to 6518FR or 6519FR Operation and Maintenance Sheet for additional information.

INSTALLATION INSTRUCTIONS FOR 6519FR (SEE INSTALLATION DRAWING SHEET 2 OF 2)

1. Cut fountain waste line (1-1/2" Tiger Flex) as required and use PVC primer and cement to attach 6519FR waste and air gap assembly. (NOTE: Locate assembly at lowest possible point inside fountain).
2. Attach 2" long piece of 1-1/2" Tiger Flex Hose (supplied) to bottom of 6519FR waste and air gap assembly tee. Next attach adaptor with tailpiece (supplied with fountain), use PVC primer and cement on these connections.

TROUBLESHOOTING 3380FR/3380GFR W/6518FR	
PROBLEM	REPAIR CHECKLIST
1. Insufficient bubbler flow.	<ol style="list-style-type: none"> a. Check that inlet screwdriver stop valve is wide open (customer supplied). b. Verify minimum 30 psi flowing supply pressure. c. Adjust valve to increase flow. See 6518FR manual.

TROUBLESHOOTING 3380.6519FR	
PROBLEM	REPAIR CHECKLIST
1. Insufficient bubbler flow.	<ol style="list-style-type: none"> a. Check that inlet screwdriver stop valve is wide open (customer supplied). b. Verify minimum 45 psi flowing supply pressure. c. Adjust valve to increase flow. See 6519FR manual.

ITEM	DESCRIPTION
1	VALVE 6518FR
2	STRAINER 0005624292
3	BUBBLER HEAD 5705FR
4	PUSH BTN ASS'Y 5881PBA
5	VALVE 6519FR (OPTIONAL)
6	VALVE BOX 6625 (OPTIONAL)

PARTS BREAKDOWN

3380FR/3380GFR WITH 6518FR OR 6519FR

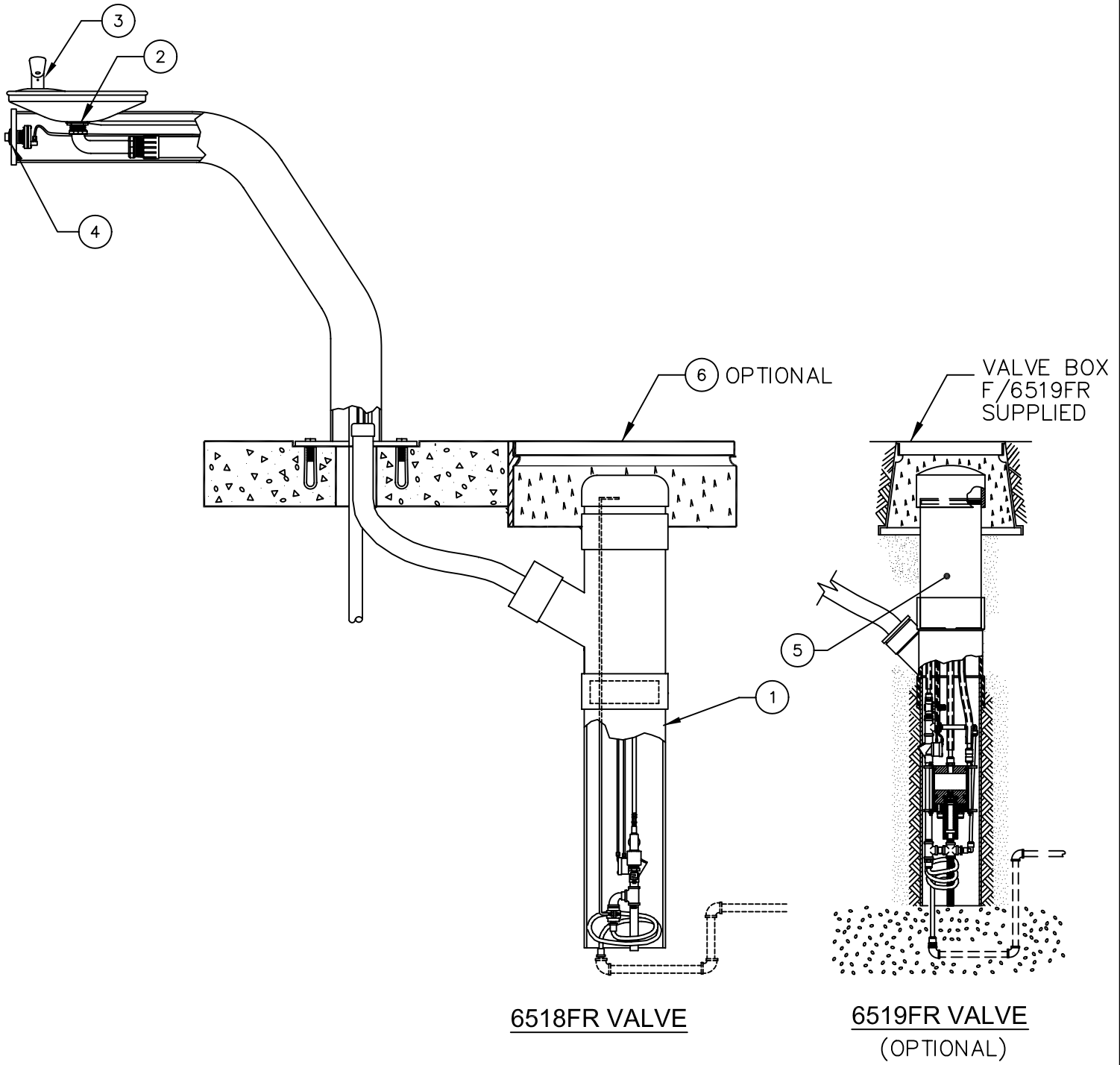

6518FR VALVE

6519FR VALVE (OPTIONAL)

WHEN ORDERING PARTS PLEASE SPECIFY YOUR MODEL NUMBER			1455 KLEPPE LANE SPARKS, NEVADA		BACHWEG 3 CH3401 BURGDORF SWITZERLAND	
	DRAWN BY: D. OLLOM	DATE: 11/25/95	CHECK BY:	APP'D BY:	SCALE: 1/6	
	TITLE: 3380FR/3380GFR/3380.6519FR				PART NUMBER: 0002077370	
	DRAWING TYPE: PARTS BREAKDOWN				DRAWING NUMBER: 12817C00	REV: 11

3380FR/3380GFR WITH 6518FR
 (SEE SHEET 2 OF 3 FOR 6519FR INSTALLATION)

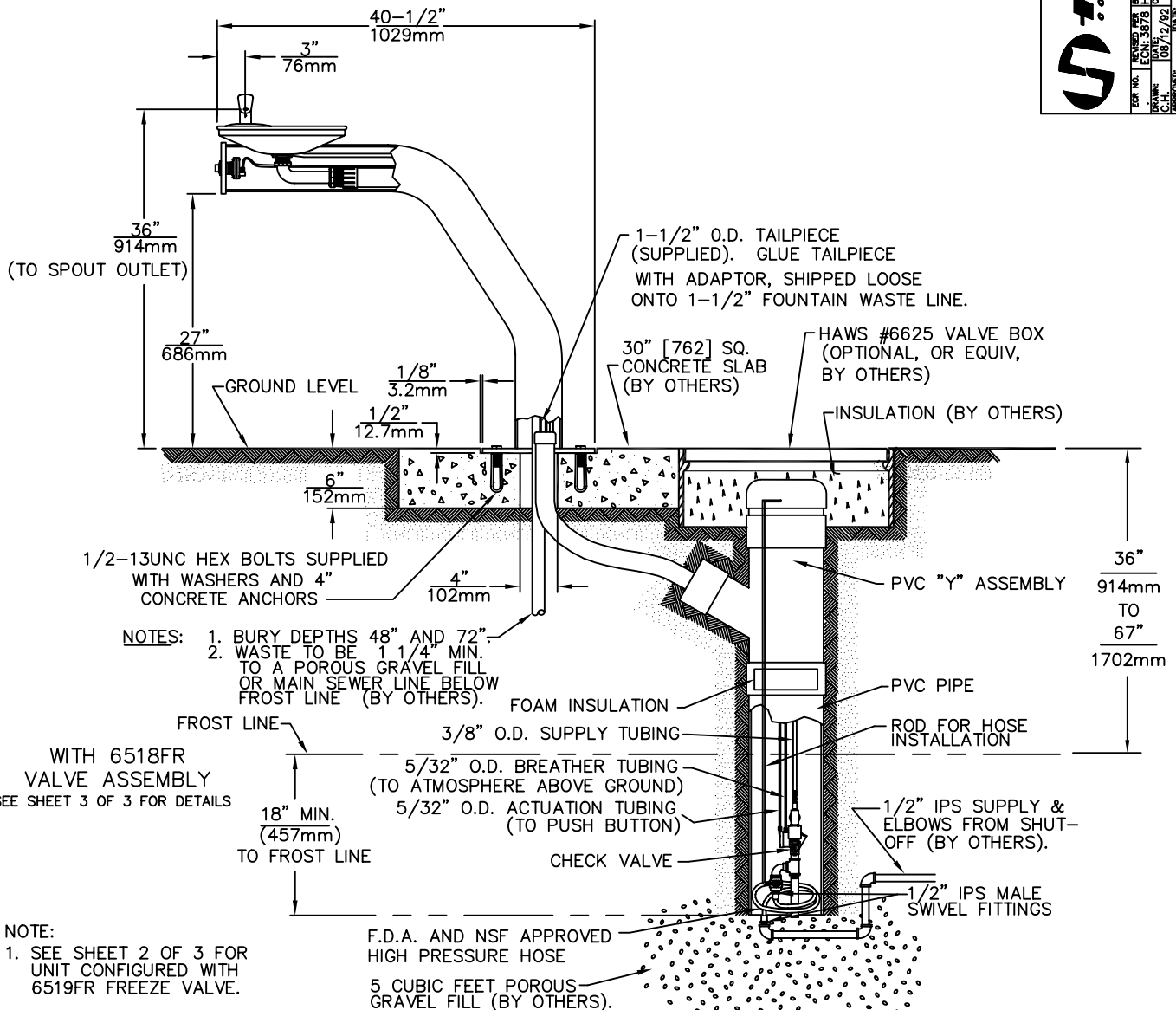
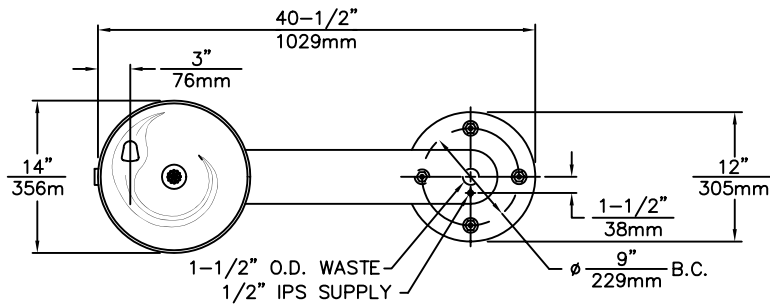

INFO FAX : 1-888-FAX-HAWS (1-888-329-4297)
 1455 Kleppe Ln, Sparks NV, 89431
 Phone: 775-359-4712 Fax: 775-359-7424
 Haws Ag Bachweg 3 CH-3401 Birsadorf Switzerland
 Haws Mfg Pte Ltd 74 Sungei Kadut Loop Singapore 729631
 e-mail: haws@hawsco.com website: www.hawsco.com

Haws Corporation

MODEL(S): 3380FR/3380GFR/3380.6519FR
 PART NUMBER: 0002077370.D
 DRAWING NUMBER: 10289A00
 REV: 11
 SIZE: A
 SHEET: 1 OF 3

DATE: 08/12/09
 DESIGNED BY: [REDACTED]
 CHECKED BY: [REDACTED]
 APPROVED BY: [REDACTED]

SCALE: 1:17 DRAWING TYPE: INSTALLATION/BACK

THIS DOCUMENT IS TRUE AND CORRECT AT TIME OF PUBLICATION. CONTINUED PRODUCT IMPROVEMENTS MAKE SPECIFICATIONS AND MEASUREMENTS SUBJECT TO CHANGE WITHOUT NOTICE.

©2006 Haws Corporation - All Rights Reserved HAWS® and other trademarks used in these materials are the exclusive property of Haws Corporation.

3380FR/3380GFR WITH 6519FR
 (SEE SHEET 1 OF 3 FOR FOUNTAIN & 6518FR INSTALLATION)

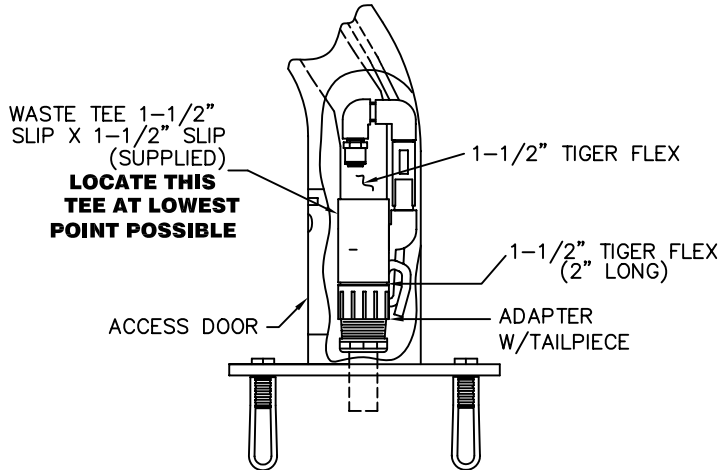

WASTE W/AIR GAP ASSY. DETAIL

WITH 6519FR VALVE ASSEMBLY
 SEE SHEET 3 OF 3 FOR DETAILS

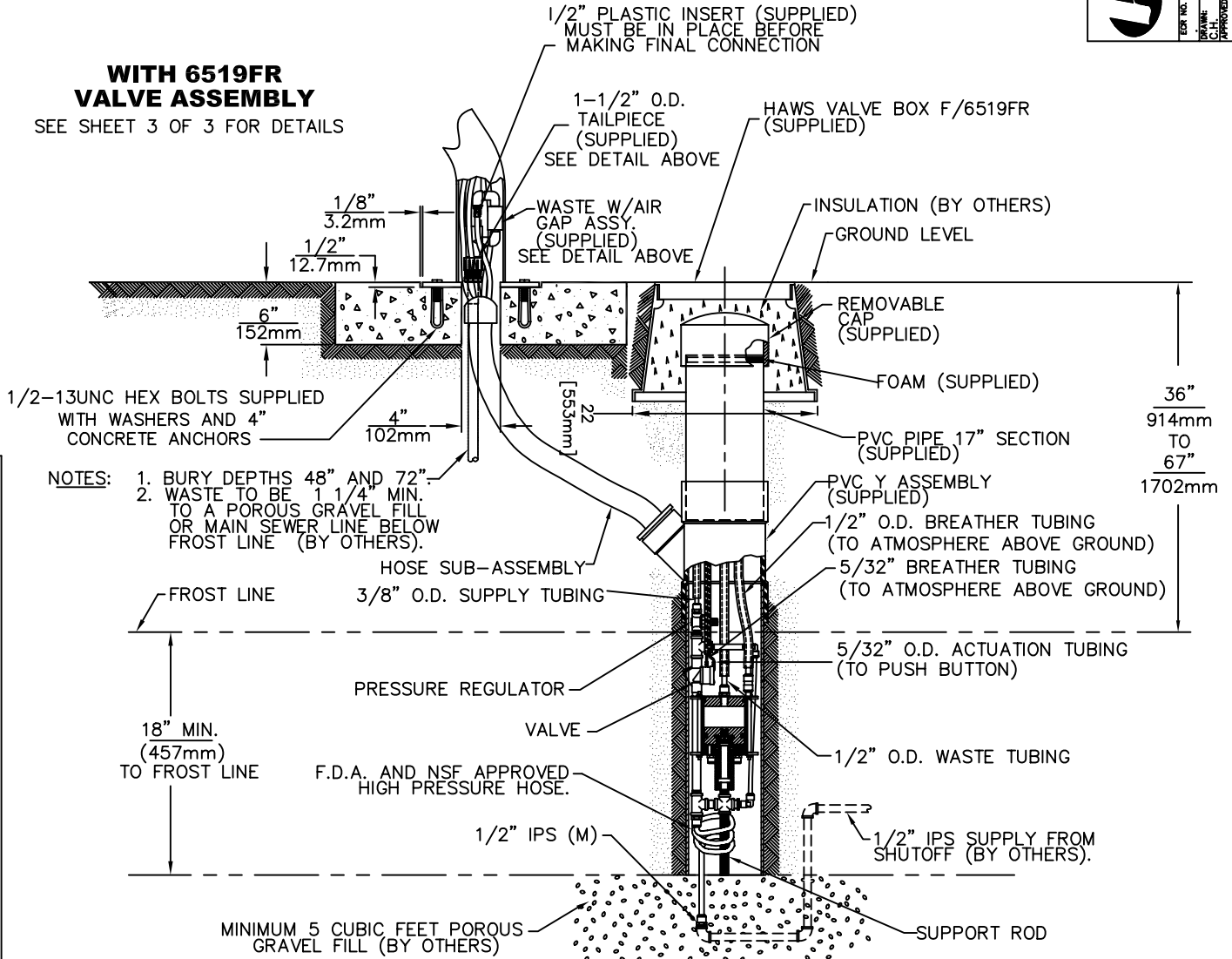

- NOTES:**
1. BURY DEPTHS 48" AND 72".
 2. WASTE TO BE 1 1/4" MIN. TO A POROUS GRAVEL FILL OR MAIN SEWER LINE BELOW FROST LINE (BY OTHERS).

Haws Corporation

INFO FAX : 1-888-FAX-HAWS (1-888-329-4297)
 1455 Kleppe Ln, Sparks NV, 89431
 Phone: 775-359-4712 Fax: 775-359-7424
 Haws Ag Bachweg 3 CH-3401 Burgdorf Switzerland
 Haws Mfg Pte Ltd 74 Sungei Kadut Loop Singapore 729531
 e-mail: Haws@hawsco.com website: www.hawsco.com

PART NUMBER: 0002077370.D
 DRAWING NUMBER: 10289A00
 REV: 11
 SHEET: 2 OF 3

MODEL(S): 3380FR/3380GFR/3380.6519FR
 INFO FAX DOC #: 23380437/23380651
 SCALE: 1:19 DRAWING TYPE: INSTALLATION/BACK

THIS DOCUMENT IS TRUE AND CORRECT AT TIME OF PUBLICATION. CONTINUED PRODUCT IMPROVEMENTS MAKE SPECIFICATIONS AND MEASUREMENTS SUBJECT TO CHANGE WITHOUT NOTICE.

©2006 Haws Corporation - All Rights Reserved HAWS® and other trademarks used in these materials are the exclusive property of Haws Corporation.

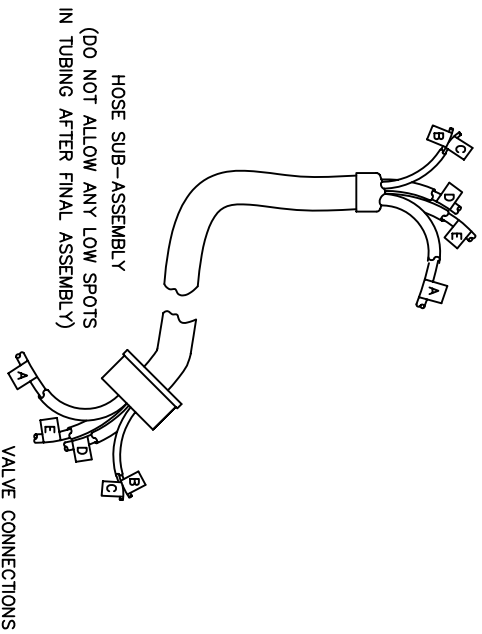

FOUNTAIN CONNECTIONS
(FOLLOW INSTRUCTIONS ON LABELS)

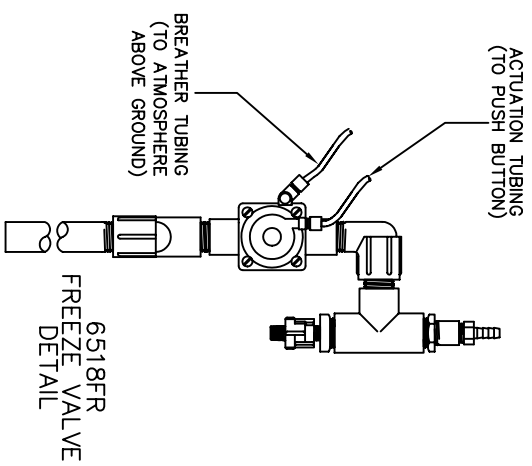

CAUTION: VALVE ASSEMBLY MUST BE KEPT VERTICAL AT ALL TIMES. USE TEMPORARY STAND PROVIDED UNTIL VALVE INSTALLATION IS FINALIZED.

6519FR FREEZE VALVE DETAIL
(3 WAY DIVIDER W/TUBING AT BASE NOT SHOWN FOR CLARITY)

FOAM INSULATION
DO NOT LEAVE ANY TUBING EXPOSED

3/8" O.D. SUPPLY TUBING
(TO BUBBLER HEAD)
(LABEL A)

PRESSURE REGULATOR

VALVE

1/2" O.D. WASTE TUBING
(TO AIR GAP ASSY)
(LABEL D)

5/32" O.D. BREATHER TUBING
(TO ATMOSPHERE ABOVE GROUND)
(LABEL C)

5/32" O.D. ACTUATION TUBING
(TO PUSH BUTTON)
(LABEL B)

1/2" O.D. BREATHER TUBING
(TO ATMOSPHERE ABOVE GROUND)
(LABEL E)

USE THIS NIPPLE AS A HOOKING POINT FOR ROD (SUPPLIED) WHEN LIFTING OR LOWERING VALVE INTO CASING

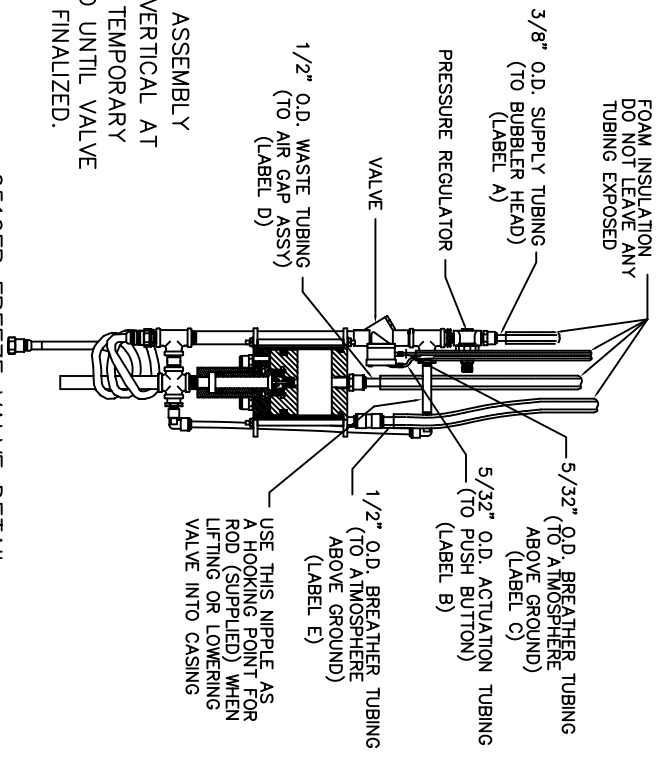

Haws Corporation		INFO FAX : 1-888-FAX-HAWS (1-888-329-4297) 1455 Kiappa Ln, Sports NY, 89431 Phone: 775-359-4712 Fax: 775-359-7424 Haws Ag Building 3 CH-3401 Burgdorf, Switzerland Haws Mfg Pte Ltd 74 Sungai Kodut Loop Singapore 729531 e-trail: Haws@hawsco.com website: www.hawsco.com	
REG. NO. 3380FR ECN: 3478 DATE: 05/16/06 APPROVER:	MODEL(S): 3380FR/3380GFR/3380.6519FR INFO FAX DOC # 233803/23380437/23380651	DATE: 05/16/06 APPROVER:	DATE: 05/16/06 APPROVER:
P.O. BOX 7370 D 10289A00 11		SIZE: A SH: 3" x 3"	