

Engineering Specification: Zurn AquaSpec® Z842X1-XL-AF

Polished chrome plated cast brass 8" [203mm] pre-rinse faucet with quarter turn ceramic disc cartridges, 3/8 [10mm] short swivel inlets with check stops providing adjustable centers from 7-1/4" [184mm] to 8-3/4" [222mm] and 2-1/2" [64mm] vandal resistant color-coded metal lever handles. Unit is furnished with a single valve Adapta faucet with a 9-1/2" [241mm] swing spout and single screen outlet, a 24" [610mm] riser with a 36" [914mm] stainless steel spring hose, a 1.6 GPM @ 60 psi (6.1 l/min. @ 400 kPa) self-closing pre-rinse hand held valve with an insulated handle, a stay open clip, a protective bumper spray head, a wall mounted pipe support and a hose hook.

Zurn Lead Compliant* "XL" products are a line of durable, high quality brass faucets and fixtures that are designed and manufactured to comply with state laws and local codes that mandate lead content levels. Zurn "XL" products are manufactured with *not more than 0.25% lead content when used with respect to wetted surfaces of pipes and pipe fittings, plumbing fitting and fixtures: California Health & Safety Code § 116875; Vermont 9 VCA § 2470h

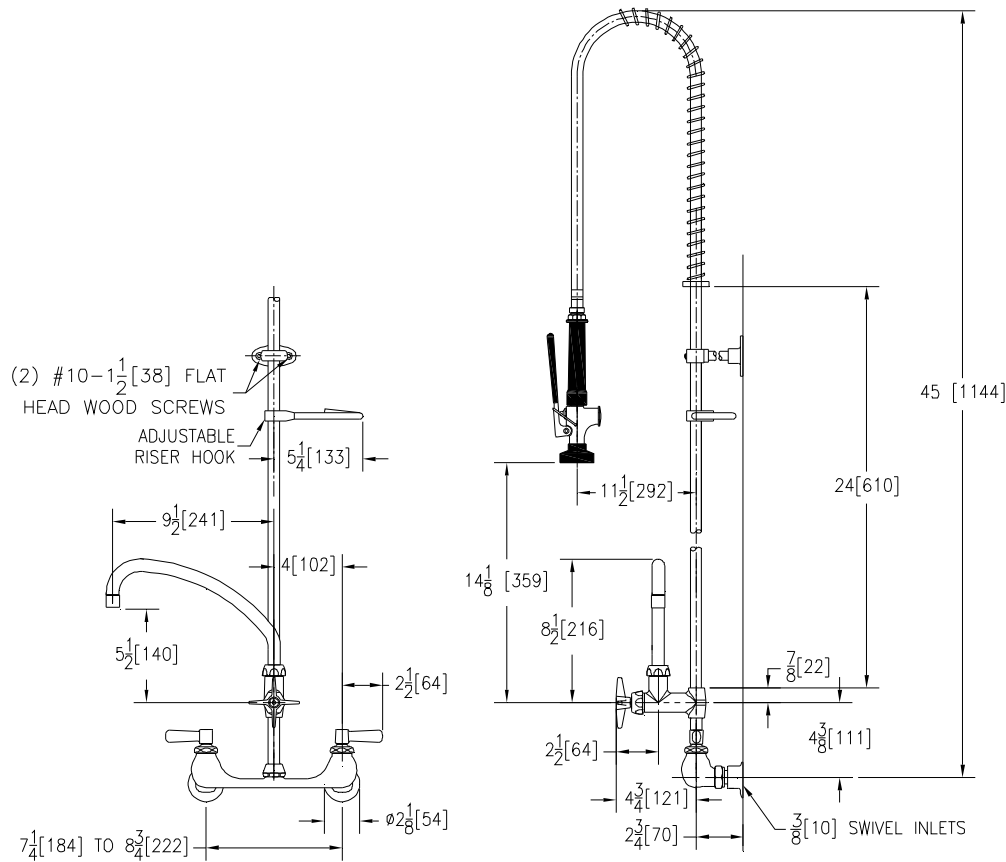

Note: All dimensions are for reference only. Do not use for pre-plumbing.

OPTIONAL ACCESSORIES

Suffix	Description
—HCT	Hot/Cold Text Indexes
—LSI	2-1/2" [64mm] Long Swivel Inlets with Integral Stops
—PR2	Pre-Rinse with Angle Spray Head, Rubber Bumper Spray Outlet and Self-closing Valve

ZURN INDUSTRIES, LLC ♦ COMMERCIAL BRASS OPERATION ♦ 2640 SOUTH WORK STREET ♦ FALCONER NY 14733

Phone: 1-800-997-3876 ♦ Fax: 1-919-775-3541 ♦ www.zurn.com

In Canada: ZURN INDUSTRIES LIMITED ♦ 3544 Nashua Drive ♦ Mississauga, Ontario L4V1L2 ♦ Phone: 905/405-8272 Fax: 905/405-1292