



Cumberland Series™ Faucet

Sensor-Operated Lavatory Faucets for
Battery or Plug-In Installations.

Installation, Operation, Maintenance,
and Parts Manual

Patented and Patents Pending



**Z6956-XL
Cumberland Series**

**Sensor-Operated Battery-Power or Plug-in
Lavatory Faucets**

LIMITED WARRANTY

All goods sold hereunder are warranted to be free from defects in material and factory workmanship for a period of three years from the date of purchase. Decorative finishes warranted for one year. We will replace at no costs goods that prove defective provided we are notified in writing of such defect and the goods are returned to us prepaid at Sanford, NC, with evidence that they have been properly maintained and used in accordance with instructions. We shall not be responsible for any labor charges or any loss, injury or damages whatsoever, including incidental or consequential damages. The sole and exclusive remedy shall be limited to the replacement of the defective goods. Before installation and use, the purchaser shall determine the suitability of the product for his intended use and the purchaser assumes all risk and liability whatever in connection therewith. Where permitted by law, the implied warranty of merchantability is expressly excluded. If the products sold hereunder are "consumer products," the implied warranty of merchantability is limited to a period of three years and shall be limited solely to the replacement of the defective goods. All weights stated in our catalogs and lists are approximate and are not guaranteed.

NOTICE: READ ENTIRE MANUAL PRIOR TO INSTALLING PRODUCT.

⚠ WARNING: Cancer and Reproductive Harm - www.P65Warnings.ca.gov

⚠ ADVERTENCIA: Cáncer y daño reproductivo - www.P65Warnings.ca.gov

⚠ AVERTISSEMENT: Cancer et effets néfastes sur la reproduction - www.P65Warnings.ca.gov

NOTE: The information in this manual is subject to change at any time without notice. Installations may be performed at different times of construction by different individuals. For this reason, these instructions should be left on-site with the facility or maintenance manager.

Cumberland Series Faucet Package Contents

Z6956-XL

Required Tools:

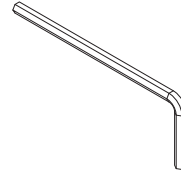
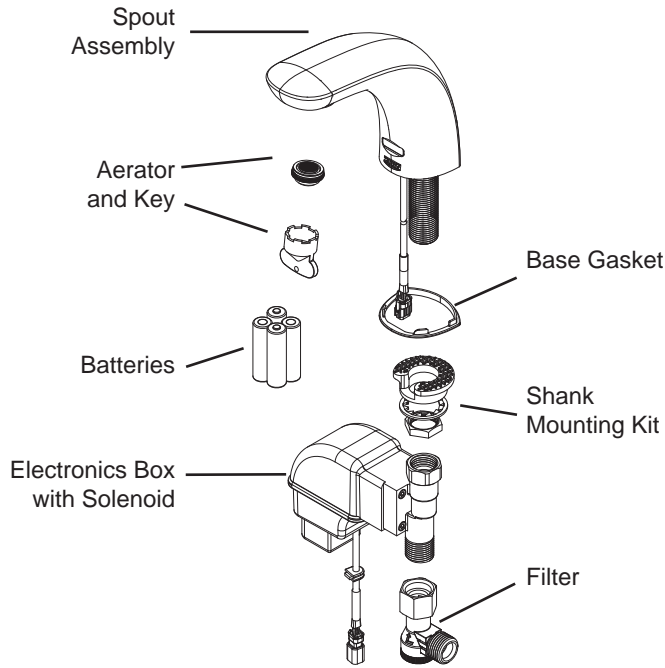

Allen Wrench: M3
(Supplied)

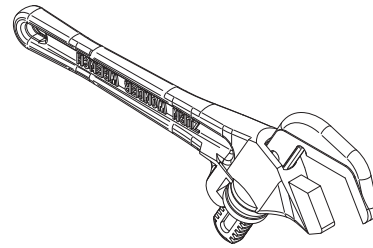

Non-toothed
Wrench

Overview:

Specifications:

Voltage:	6 VDC Series [4 "AA" (Alkaline) and/or external power option]
Sensor Range:	Self-calibrated
Operating Water Pressure:	10-125 psi
Operational Water Temperature:	33°F to 140°F (1°C to 60°C)
Aerator:	0.5 GPM (Standard)

Important Safety Information:

- Installer is responsible for ensuring the product is installed and conforms to all plumbing codes and ordinances.
- Do not convert or modify this Zurn product yourself. All warranties will be voided.
- Water supply lines must be sized according to building designer in order to provide adequate water supply for each fixture.
- Flush all water lines prior to making connections.

Prior to Installation:

Before installing your Zurn® Cumberland Series Faucet: the items listed below should already be installed on site.

- Lavatory/sink
- Drain Line
- Hot and cold water supply line or pre-tempered water supply line.
- Installer/Serviceur should not use pipe dope or teflon/thread sealant anywhere on this product, most notably threads and connection points.
- Care shall be taken when installing this product to prevent marring of any exposed or decorative surfaces.

NOTE: Before installation, turn off water supplies to existing faucet and remove faucet if replacing an existing device. Clean the faucet basin and clear away debris. Flush all supply lines before connecting the faucet. Failure to do so may result in debris clogging the inlets and/or internal control and mixing valve

Spout Installation - Step 1

1.1. Carefully screw aerator into spout using included tool.

! Take care to not pinch blue o-ring

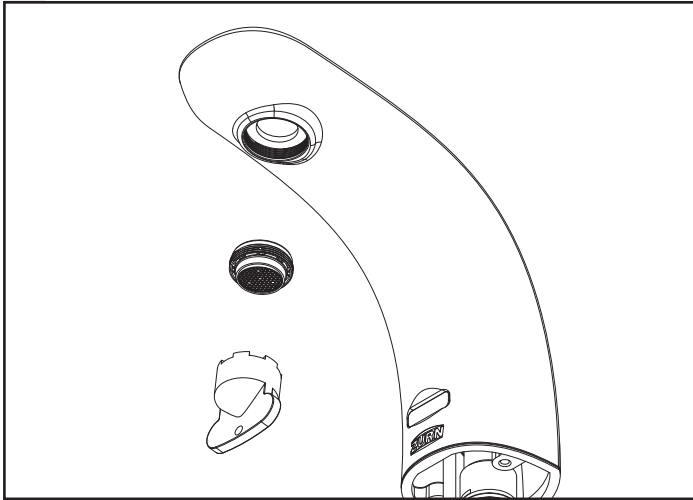

1.2. Install spout to sink using spout base gasket, plastic mounting washer, star washer and mounting nut (and cover plate for versions that are included).

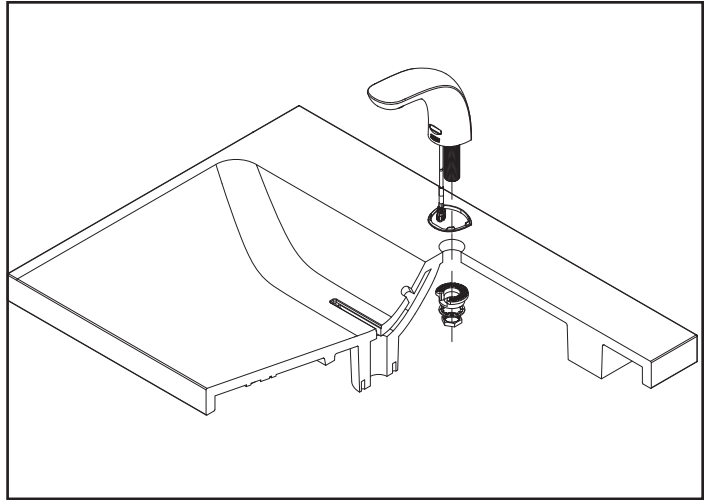

1.3. Ensure that slot in plastic washer is facing forward.

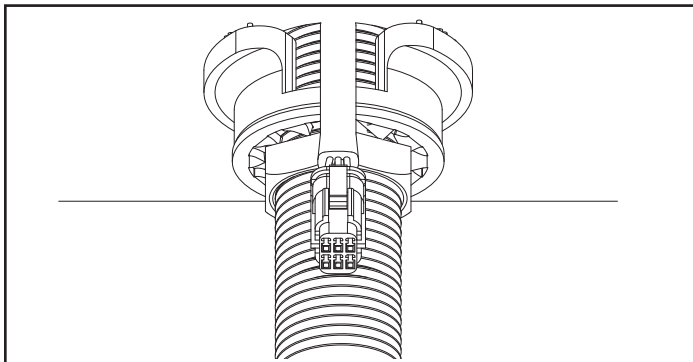

! Take care passing sensor cable through hole. Cable passes through front of plastic mounting washer

Electronics Module Installation - Step 2

2.1. Assemble the electronics module

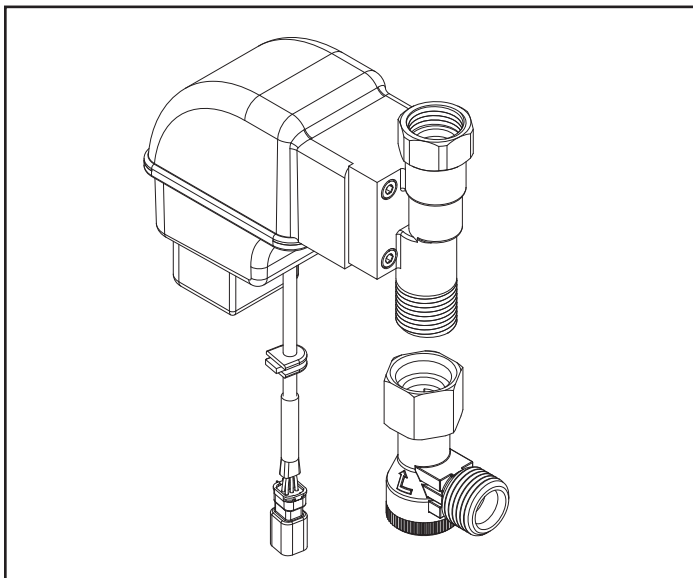

2.2. Open battery module using supplied Allen wrench and install supplied batteries in the electronics module.

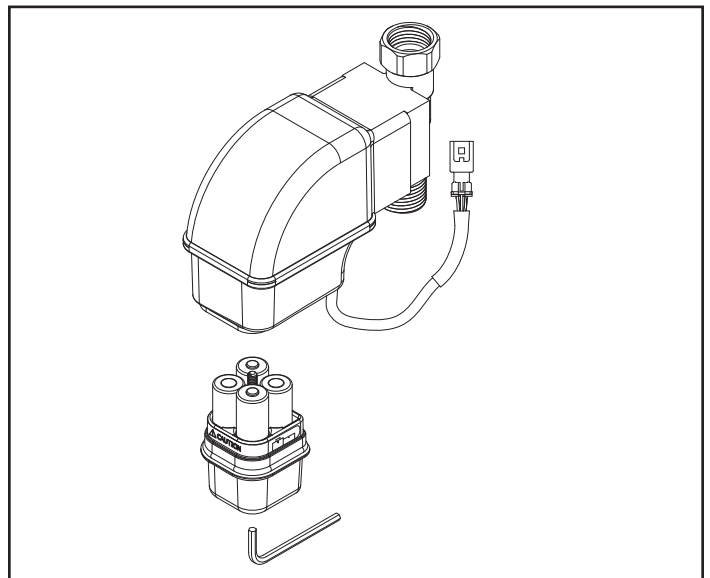

2.2a. Optional ACA version: Connect supplied AC adapter to power port on electronics box.

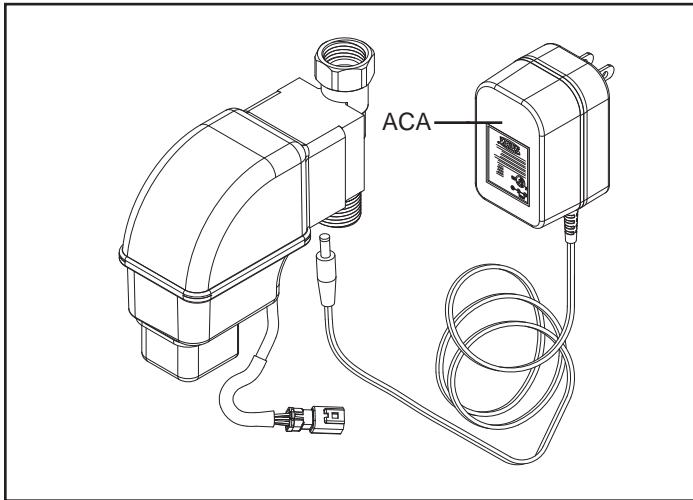

2.2b. Optional HW6 (Hardwired 6V) version: Connect supplied inline connector and hardwire adapter. When securing the CWB wires to the screw terminals on HW6 unit, the BLACK WITH DASHED MARKINGS should be connected to the Positive (+) terminal, and the SOLID BLACK wire should be connected to the Negative (-) terminal.

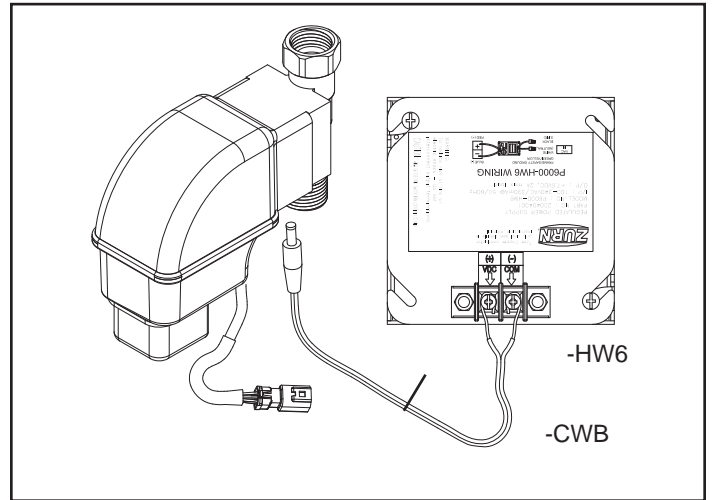

MJ unit (sold separately)

Note: Do not connect more than 8 solenoids to a single transformer

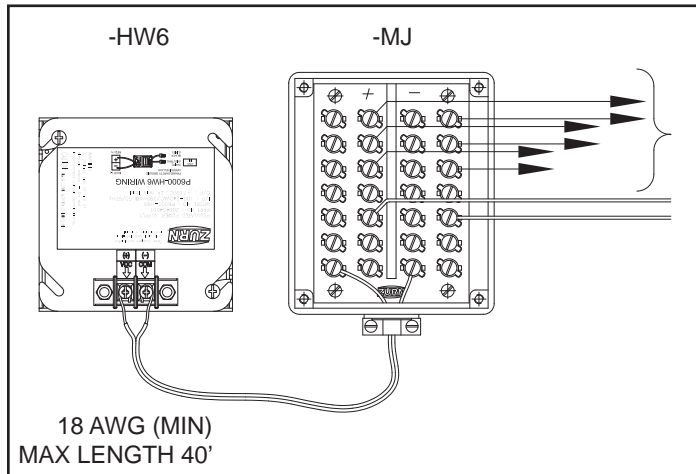

2.3. Tighten electronics module assembly to shank and connect water line(s).

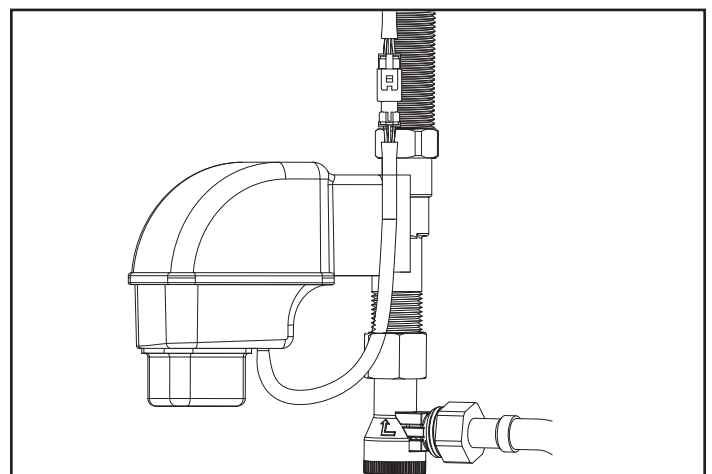

2.4. Ensure that sink is clear of tools/debris and is in normal operating condition.

2.5. Turn on water supply(ies). Water supply must be turned on in order for sensor to perform wet calibration step.

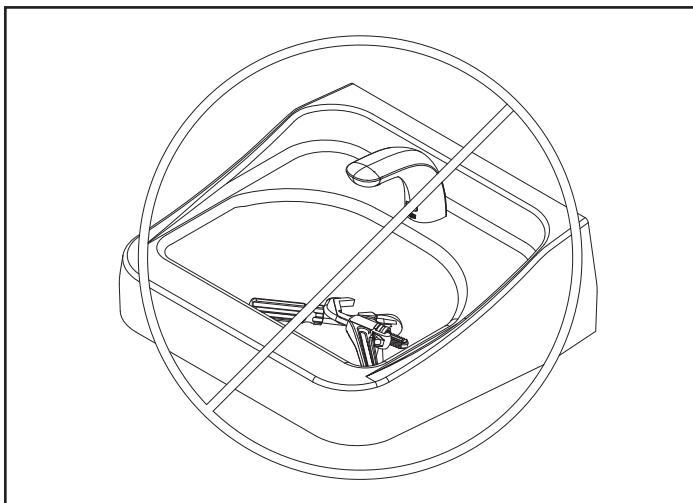

⚠ Do not engage the sensor for 30 seconds after the connection is made. The sensor will perform automatic calibration.

TROUBLESHOOTING GUIDE:

POTENTIAL SITUATIONS	POSSIBLE CAUSES	SUGGESTED SOLUTION TIPS
Faucet is non-responsive	Battery voltage low or no power.	Change out batteries or verify power provided by HW6 or ACA
	Sensor and electronic connector cable has bent or broken pins.	Check to see if pins are missing, bent, or broken. If yes, then the electronic box needs replaced
	Sensor lens could have surface damage, scratches, or deposit build ups.	"Inspect the sensor lens underneath the spout tip. May require cleaning with a damp cloth or sensor replacement"
Faucet does not activate after initial installation	Sensor may not have had enough time to calibrate prior to a user or target trying to initiate activation.	Disconnect the sensor and electronic box cables and wait for 30 seconds. Reconnect the cables, but allow for another 30 seconds before placing hands or a target within the sensor range. You should hear a click of the solenoid once calibration is complete.
	Check if protective film was removed from lens.	
Water does not stop	Electronics box cable connector has bent pins that are shorted	Check to see if pins are missing, bent, or broken. If yes, then the electronic box needs replaced.
Ghost Activation	Sensor lens could be obstructed or environmental factors such as high reflective surfaces and/or bright sunlight conditions.	Check/clean sensor lens of any debris or buildup If sunlight or IR interference is a factor.
"Sensor faucet is leaking underneath the sink or counter"	Mounting hardware is not tightened sufficiently (faucet shank, electronic box, supply hoses, etc)	Check and ensure the nuts and joints are tight and secure from the supply stop all the way to the faucet shank.
	Missing the washer located in the solenoid box nut where it assembles to the faucet tank	Make sure the water supply stops are shut off. Check to ensure the washer is installed or damaged. If not, install washer if it was not damaged, replace with new.

Care and Cleaning Instructions:

- Do not use any abrasive or chemical cleaners to clean the faucets.
- If abrasives or chemicals are used it can lead to dulling of luster, attacking of chrome plating or decorative finishes.
- ONLY use mildly warm soapy water, and then wipe the device dry with a clean/soft towel or cloth.
- Upon cleaning other areas of the restroom be sure the sensor lenses are protected from other cleaning chemicals/solvents to prevent potential damages to the sensor and/or electronics.

Z6956-XL Parts List

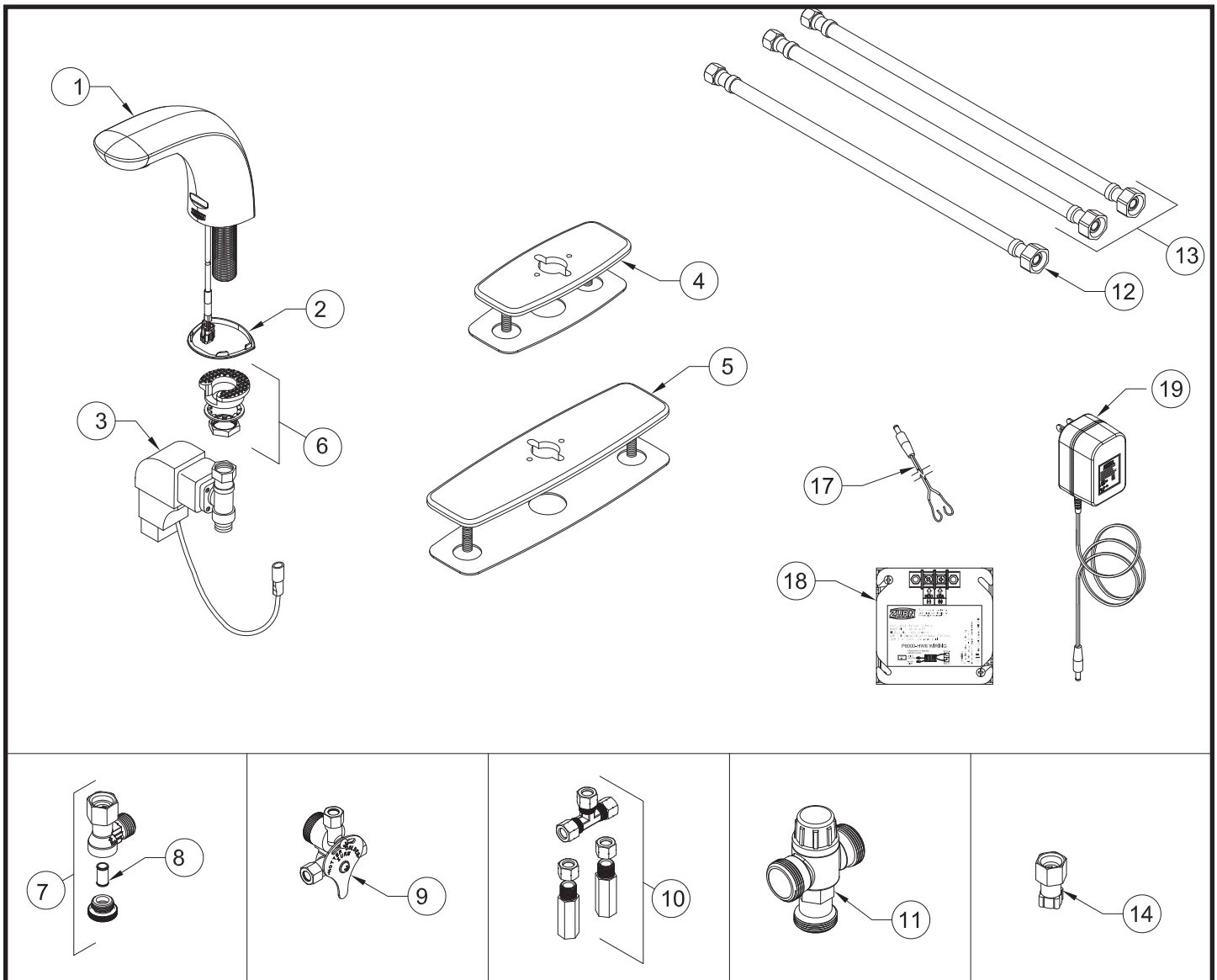

Description	Product No.
1 Z6956 Spout Assembly with Sensor	P6956-XL-1
2 Z6956 Spout base gasket	P6956-XL-42
3 Electronics Box with Solenoid	P6956-XL-B-L
4 4" Cast Cover Plate w/Gasket	P6900-CP4
5 8" Cast Cover Plate w/Gasket	P6900-CP8
6 Mounting Kit	P6900-43
7 Filter Kit	P6900-120
8 Filter Screen	P6900-MV-7
9 Mixing Valve w/Filter	P6900-XL-MV
10 Mixing Tee w/Filters and Back Checks	P6900-XL-MT

Description	Product No.
11 Thermostatic Mixing Valve	P6900-TMV
12 Single Stainless Supply Hose (XL)	P6900-SSH
13 Stainless Supply Hoses (XL)	P6900-SSH-2
14 Composite Mixing Valve Adaptor	P6900-MV-ADAP
15 Shank Connection Gasket	P6900-SG
16 "Solenoid Rebuild Kit (Diaphragm, plunger and plunger spring)"	P6900-SRK
17 -CWB Pigtail	P6900-CWB
18 -HW6 Power Supply	P6900-HW6
19 Optional Plug-in Power Converter	P6900-ACA