

Halsey Taylor Installation Manual

Model 2205 Fountain

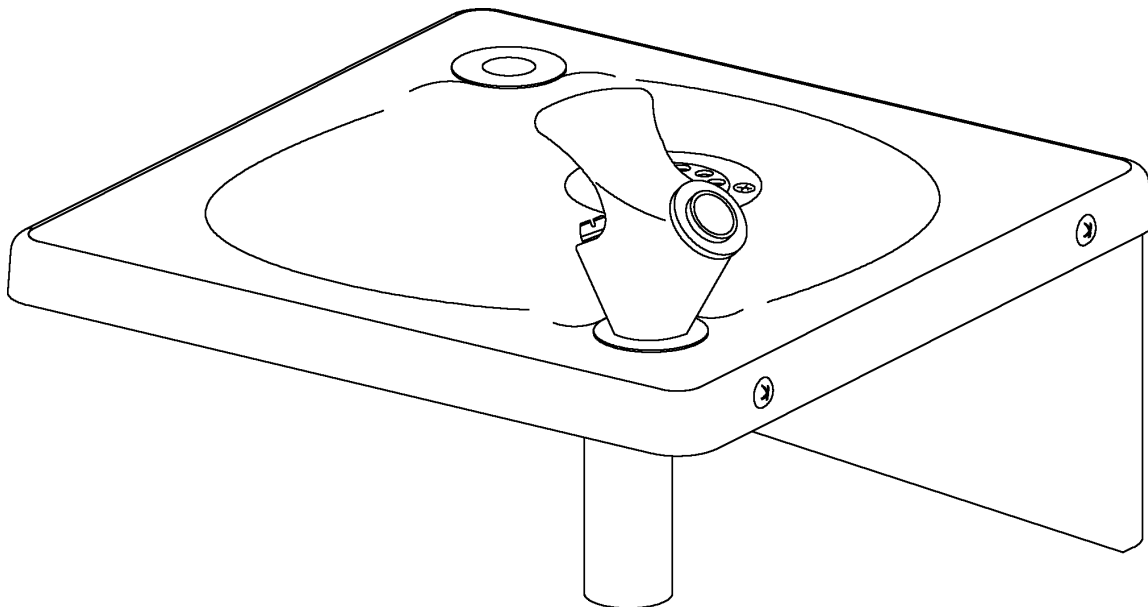

Installer

To assure you install this model easily and correctly,
PLEASE READ THESE SIMPLE INSTRUCTIONS BEFORE STARTING THE
INSTALLATION. CHECK YOUR INSTALLATION FOR COMPLIANCE WITH
PLUMBING, ELECTRICAL AND OTHER APPLICABLE CODES. After installation, leave these
instructions inside the fountain for future reference.

IMPORTANT

ALL SERVICE TO BE PERFORMED BY AN AUTHORIZED SERVICE PERSON

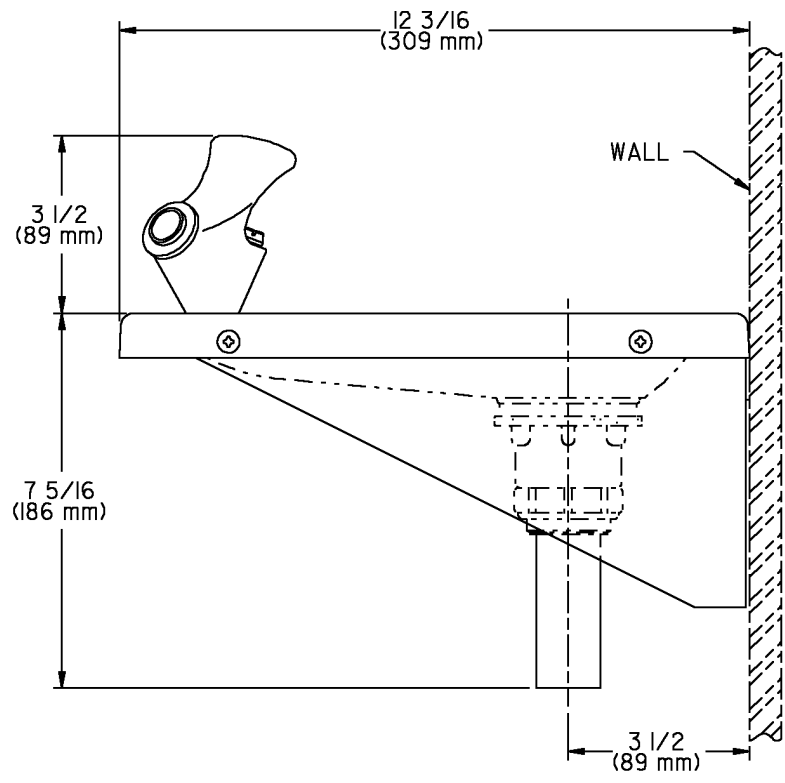

SIDE VIEW

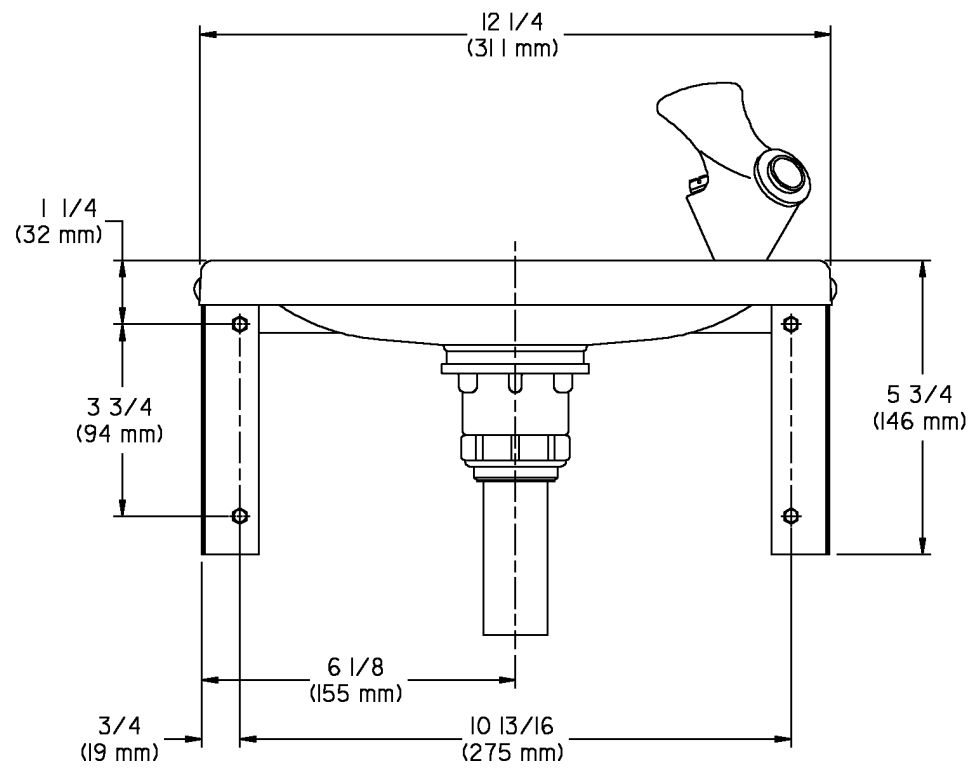

FRONT VIEW

ASSEMBLY

1. Assemble support brackets to the fountain by aligning holes in bracket with holes in cooler and fastening with (4) #10 screws provided.
2. Slide drain tube into drain fitting and secure by sliding drain nut over drain tube and tightening nut to drain fitting.
3. Attach bubbler to fountain by inserting bubbler nipple through the hole in the cooler top and securing with the washer and nut provided.

INSTALLATION

1. This fountain is to be mounted on a smooth, flat, finished wall surface, with adequate support structure.
2. Establish rim height fountain is to be mounted.
3. Refer to rough-in for plumbing.
4. Locate and install trap. (Trap not included).
5. Install shut-off valve on building water supply. (Shut off valve not furnished).
6. Locate and install hanger bracket using 1/4" (10mm) lag screws or bolts. (Not included).
7. Install and center fountain on hanger bracket by slipping the back edge of the cooler top over the flange on the hanger bracket. Secure fountain using 1/4" (10mm) minimum lag screws or bolts (Not included).

CAUTION: This fountain is rated for inlet water pressure of 20-90 psi. Should the inlet water supply exceed 90 psi, a pressure reducing regulator should be used.

8. Connect fountain to building supply line by running a 3/8" (10mm) water line between the shut-off valve and fountain.
9. Turn "ON" water supply and check all connections for leaks.
10. Adjust bubbler stream height. (See instructions below).

TROUBLE SHOOTING AND MAINTENANCE

Orifice Assy: Mineral deposits on orifice can cause water flow to spurt or not regulate. Mineral deposits may be removed from the orifice with a small round file not over 1/8" diameter or small diameter wire.

CAUTION: DO NOT file or cut orifice material.

Stream Regulator: If orifice is clean, regulate flow as stated below. If replacement is necessary, see parts list for correct regulator part number.

STREAM HEIGHT ADJUSTMENT: Stream height is factory set at 45-50 PSI. If supply pressure varies greatly from this, remove items 16, and 17 (See figure 2) from bubbler assembly and adjust the screw on the regulator (Item 20). Clockwise adjustment will raise stream height and counterclockwise will lower the stream height. A stream height of 1-1/2" (38mm) is recommended.

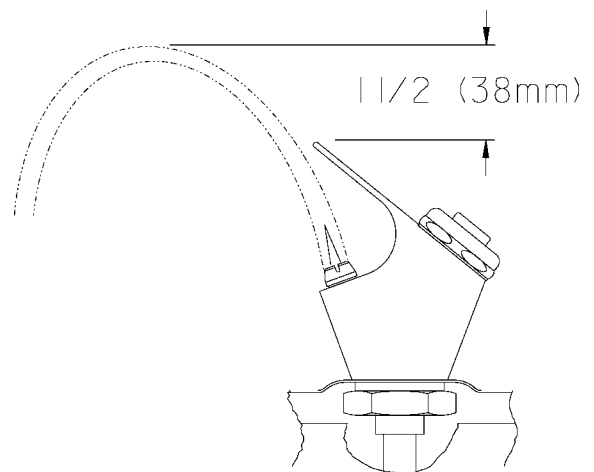

FIG. 1

ITEMIZED PARTS LIST

ITEMNO.	PARTNO.	DESCRIPTION
1	100687608640	Plug Button
2	101486340560	Drain Gasket
3	112627543890	Screw - #10-24 x .50 PHTC
4	171484242830	Basin
5	27234C	Bracket - Support LH
6	27235C	Bracket - Support RH
7	27238C	Bracket - Wall Hanger
8	40294C	Tailpipe - 1-1/4 O.D. x 4.00 IN.
9	55914C	Adapter - Drain
10	75498C	Screw - #8 x .63 FHTC
11	75588C	Nut - Slip Joint 1-1/4
12	75589C	Washer - Seal
13	LK142	Bubbler Assembly
14	10031C	Retaining Nut 1 1/8-24
15	100322740560	Gasket
16	40048C	Button
17	40089C	Cover Nut 1 1/8-24
18	40322C	Orifice Assembly
19	45675C	Bubbler Body
20	61313C	Regulator
21	70012C	Lock Nut 3/8-18
22	72460042	Metal Washer
23	A54800	Nipple
24	A54888	Screen

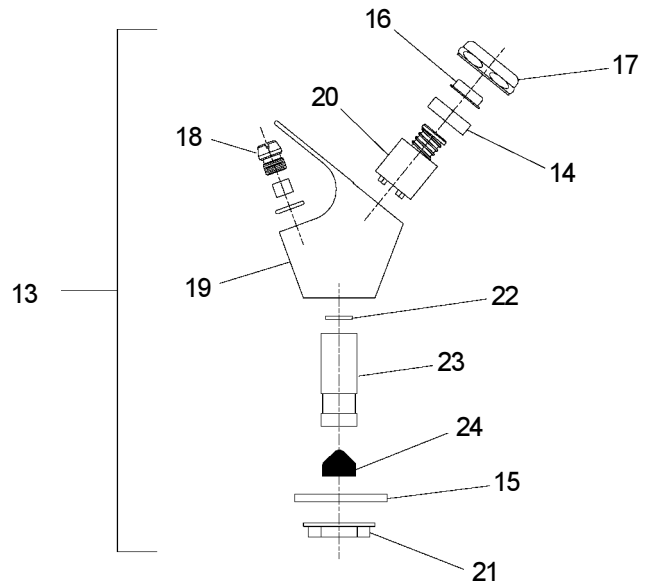

FIG. 2

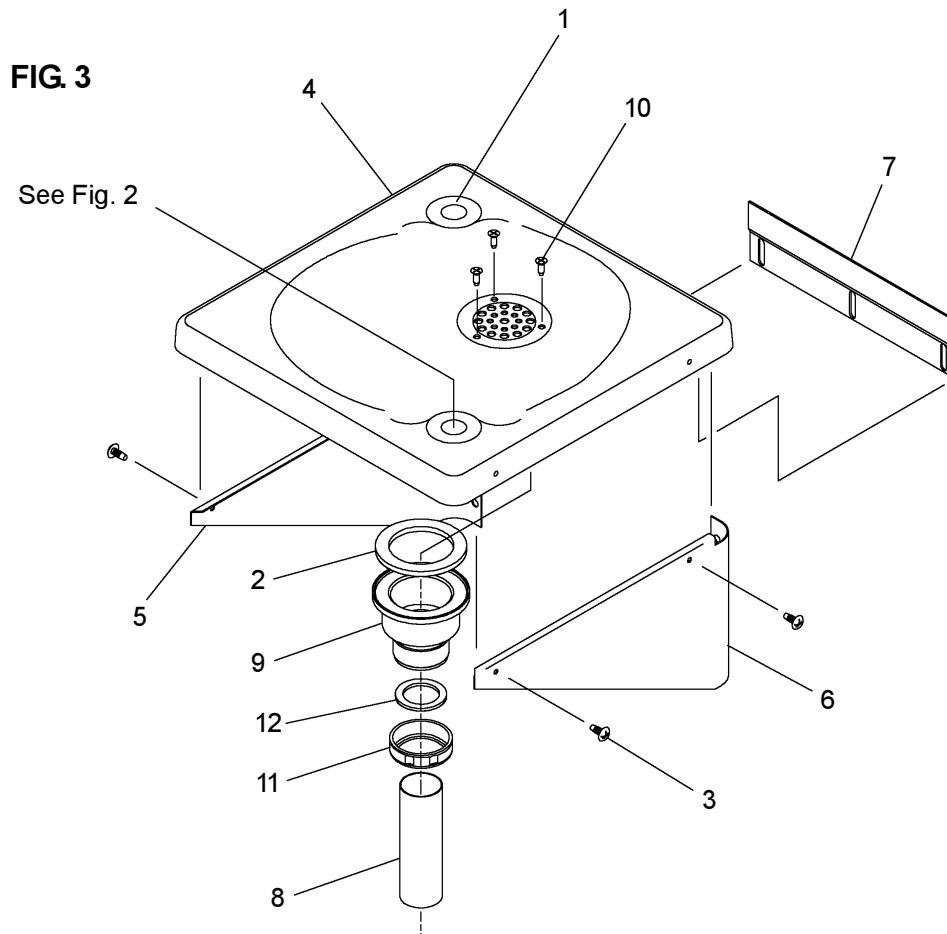

FIG. 3

Halsey Taylor
 2222 CAMDEN COURT
 OAK BROOK, IL 60523

PRINTED IN U.S.A.

www.DrinkingFountainDoctor.com

800-518-5388