

Halsey Taylor Owners Manual

Model 4405

Wall Mounted Tubular Fountain

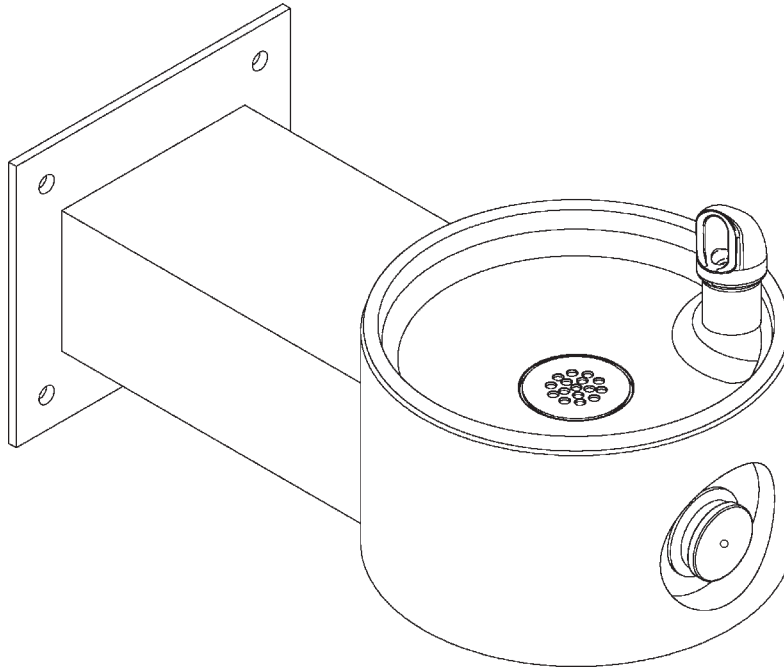

INSTALLER

Halsey Taylor Fountains are among the easiest to install Fountains on the market today. To assure you install these models easily and correctly, PLEASE READ THESE SIMPLE INSTRUCTIONS BEFORE STARTING THE INSTALLATION. CHECK YOUR INSTALLATION FOR COMPLIANCE WITH PLUMBING, ELECTRICAL, AND OTHER APPLICABLE CODES. After installation, leave these instructions with the Fountain for future reference.

IMPORTANT

ALL SERVICE TO BE PERFORMED BY AN AUTHORIZED SERVICE PERSON

IMPORTANT! INSTALLER PLEASE NOTE.

THE GROUNDING OF ELECTRICAL EQUIPMENT SUCH AS TELEPHONE, COMPUTERS, ETC. TO WATER LINES IS A COMMON PROCEDURE. THIS GROUNDING MAY BE IN THE BUILDING OR MAY OCCUR AWAY FROM THE BUILDING. THIS GROUNDING CAN CAUSE ELECTRICAL FEEDBACK INTO A FOUNTAIN, CREATING AN ELECTROLYSIS WHICH CAUSES A METALLIC TASTE OR AN INCREASE IN THE METAL CONTENT OF THE WATER. THIS CONDITION IS AVOIDABLE BY USING THE PROPER MATERIALS AS INDICATED. ANY DRAIN FITTINGS PROVIDED BY THE INSTALLER SHOULD BE MADE OF PLASTIC TO ELECTRICALLY ISOLATE THE FOUNTAIN FROM THE BUILDING PLUMBING SYSTEM.

4405 FOUNTAIN

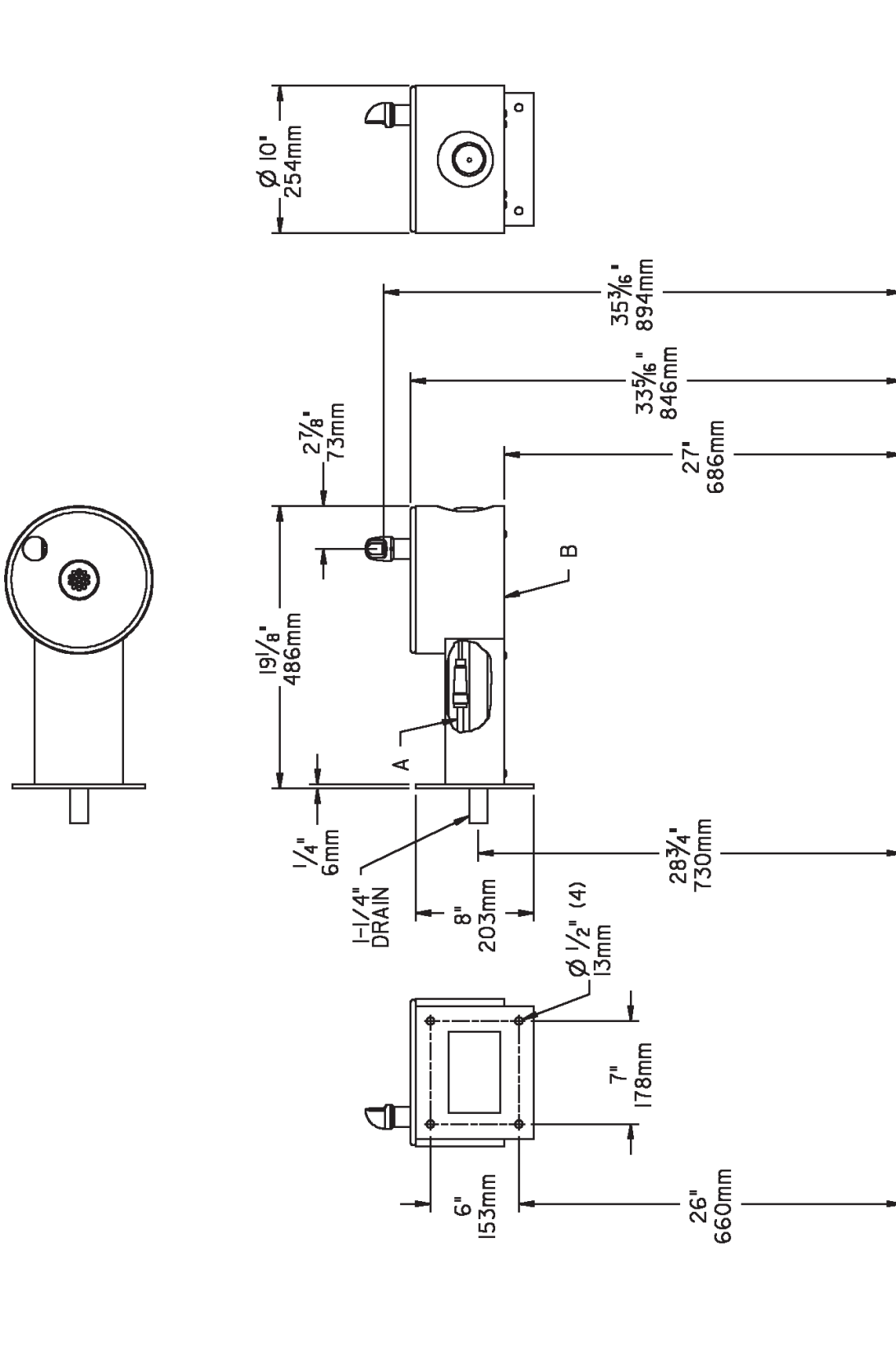

LEGEND
 A = 3/8" O.D. UNPLATED COPPER TUBE CONNECT - SHUT OFF VALVE BY OTHERS
 B = REMOVABLE BOTTOM COVER

4405 FOUNTAIN

1. This fountain is to be mounted on a smooth, flat, finished surface with adequate support structure. NOTE: Mounting structure must be capable of supporting 300 lb. load on fountain.
2. Refer to rough-in for plumbing.
3. Install shut-off valve on water supply. (Valve not furnished)
4. Locate and install fountain using 3/8" minimum screws or bolts. (Screws or bolts not furnished)
5. Connect water supply and fountain drain. Water connection and drain must comply with local codes.
6. Turn on water supply and check all connections for leaks.

CAUTION: This fountain is rated for inlet water pressure of 20-105 PSI. A pressure reducing regulator should be used if the inlet water supply exceeds 105 PSI. Any damage caused by reason of connecting this product to supply line pressures lower than 20 psig or higher than 105 psig is not covered by warranty.

7. Water supply 3/8" O.D. unplated copper tube. Waste 1-1/4" IPS. Contractor to supply waste trap and service stop valve in accordance with local code.
8. Connecting lines to be made of unplated copper and should be thoroughly flushed to remove all foreign matter before being connected to fountain. This fountain is manufactured in such a manner that it does not in any way cause taste, odor, color, or sediment problems.
9. Connect fountain to supply line with a shut-off valve and install a 3/8" unplated copper water line between the valve and the cooler. Remove any burrs from outside of water line. Push the tubes straight into the fittings until they reach a positive stop, approximately 3/4" (See Fig. 2). **DO NOT SOLDER TUBES INSERTED INTO THE STRAINER AS DAMAGE TO THE O-RINGS MAY RESULT.**

TROUBLE SHOOTING AND MAINTENANCE

Actuation of Quick Connect Water Fittings: Fountain is provided with lead-free connectors which utilize an o-ring water seal. To remove tubing from the fitting, relieve water pressure, push in on the gray collar while pulling on the tubing.(see Fig.1) To insert tubing, push tube straight into fitting until it reaches a positive stop, approximately 3/4".

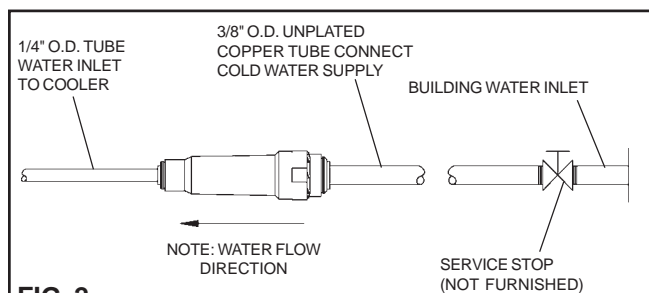
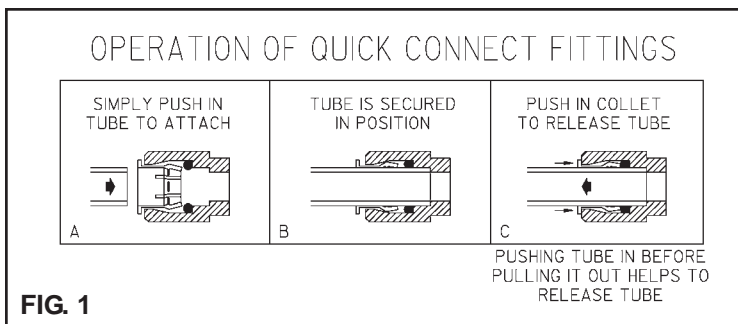

4405 FOUNTAIN

ITEMIZED PARTS LIST

ITEMNO.	PART NO.	DESCRIPTION
1	100147140560	Drain Gasket
2	28308C	Washer
3	101570540560	Drain Gasket
4	15005C	Regulator Retaining Nut
5	15009C	Nipple Assy. - Bubbler
6	28091C	Nameplate Insert
7	40045C	Hex Nut 1-5/16"
8	98118C	Bubbler Assembly
9	45464C	Drain Plug 1-1/2"
10	45823C	Fountain Body
11	45834C	Bottom Cover
12	45662C	Push Button
13	45663C	Push Button Sleeve
14	45679C	Drain Tube
15	50986C	Regulator Holder
16	56121C	Drain Elbow 1-1/4"
17	56092C	Poly Tubing (Cut To Length)
18	55996C	In - Line Strainer
19	61313C	Regulator
20	75672C	Cap Screw
21	28467C	Basin
22	75535C	Pinned Torx Screw 1/4-20 x .75"
23	100322740560	Washer
24	75588C	Slip Joint Nut 1-1/4"
25	75589C	Gasket
NS	75596C	Paint Touch-up (Pen)

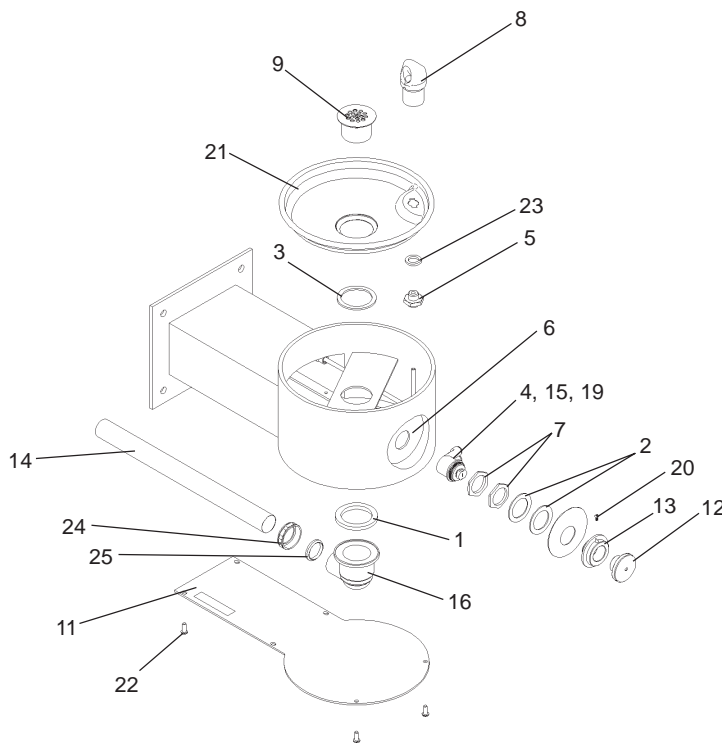

Touch-up Paint

For minor scratches a Touch-up Paint Stick is available. For repairing large defects, off-the-shelf aerosol paint from your local hardware store can be used. Listed are two suggested brandnames.

- Brandname: X-O
XO-11 Hunter Green
- Brandname: Ace Hardware
Rust Stop / Machine & Implement
International Green

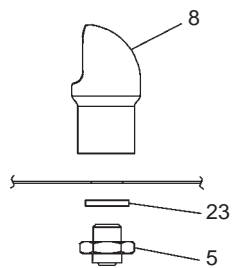
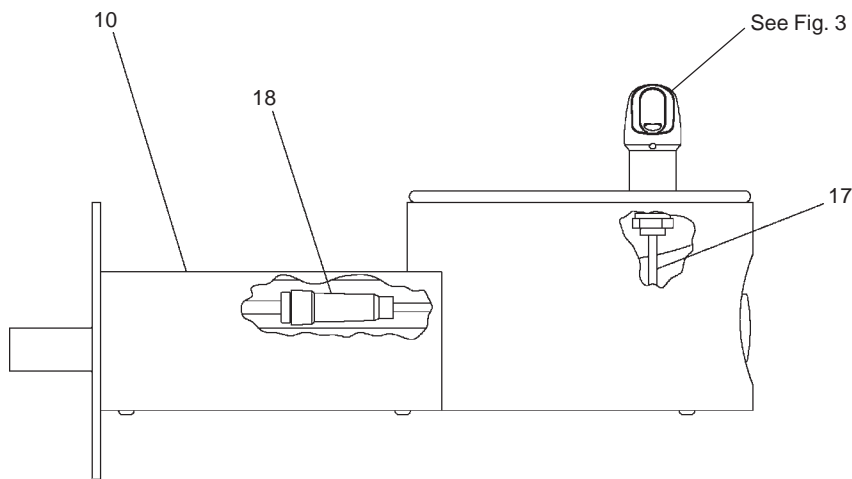

FIG. 3



Halsey Taylor
2222 CAMDEN COURT

www.DrinkingFountainDoctor.com

800-518-5388

PRINTED IN U.S.A.