

Halsey Taylor Owners Manual

Freeze Resistant Wall Mounted Steel Fountain

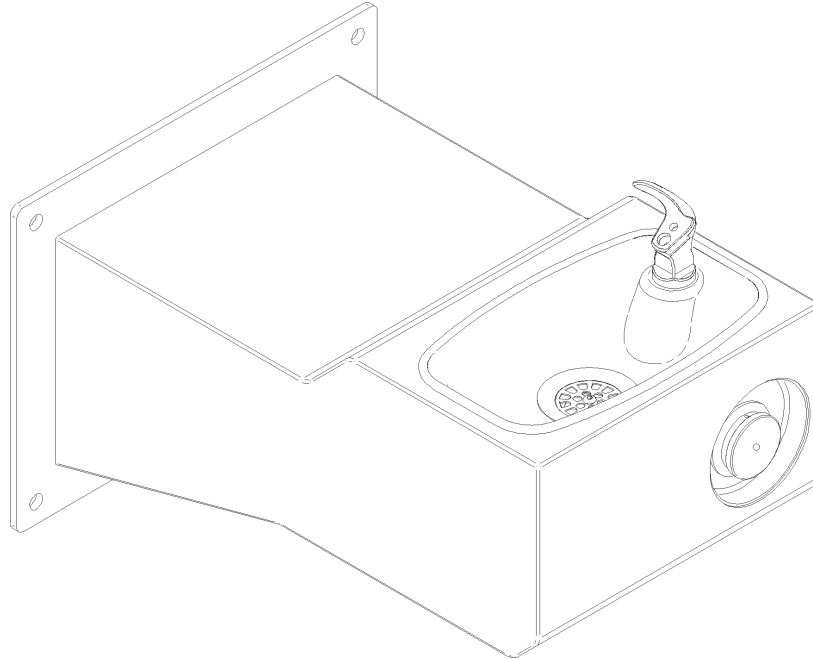

INSTALLER

Halsey Taylor Fountains are among the easiest to install Fountains on the market today. To assure you install these models easily and correctly, PLEASE READ THESE SIMPLE INSTRUCTIONS BEFORE STARTING THE INSTALLATION. CHECK YOUR INSTALLATION FOR COMPLIANCE WITH PLUMBING, ELECTRICAL, AND OTHER APPLICABLE CODES. After installation, leave these instructions with the Fountain for future reference. This Freeze Resistant Fountain is shipped in two separate cartons. The second carton(s) contains the Freeze Resistant Package(s) **HTFRB1** that are installed on an interior heated wall. The interior space must maintain a minimum temperature of 50° F (10° C). Refer to the Freeze Resistant Package for the rough-in dimensions for installation.

IMPORTANT

ALL SERVICE TO BE PERFORMED BY AN AUTHORIZED SERVICE PERSON.

IMPORTANT! INSTALLER PLEASE NOTE.

THE GROUNDING OF ELECTRICAL EQUIPMENT SUCH AS TELEPHONE, COMPUTERS, ETC. TO WATER LINES IS A COMMON PROCEDURE. THIS GROUNDING MAY BE IN THE BUILDING OR MAY OCCUR AWAY FROM THE BUILDING. THIS GROUNDING CAN CAUSE ELECTRICAL FEEDBACK INTO A FOUNTAIN, CREATING AN ELECTROLYSIS WHICH CAUSES A METALLIC TASTE OR AN INCREASE IN THE METAL CONTENT OF THE WATER. THIS CONDITION IS AVOIDABLE BY USING THE PROPER MATERIALS AS INDICATED. ANY DRAIN FITTINGS PROVIDED BY THE INSTALLER SHOULD BE MADE OF PLASTIC TO ELECTRICALLY ISOLATE THE FOUNTAIN FROM THE BUILDING PLUMBING SYSTEM.

4705 FREEZE RESISTANT STEEL FOUNTAIN
MOUNTING HOLE AND ACCESS HOLE LAYOUT

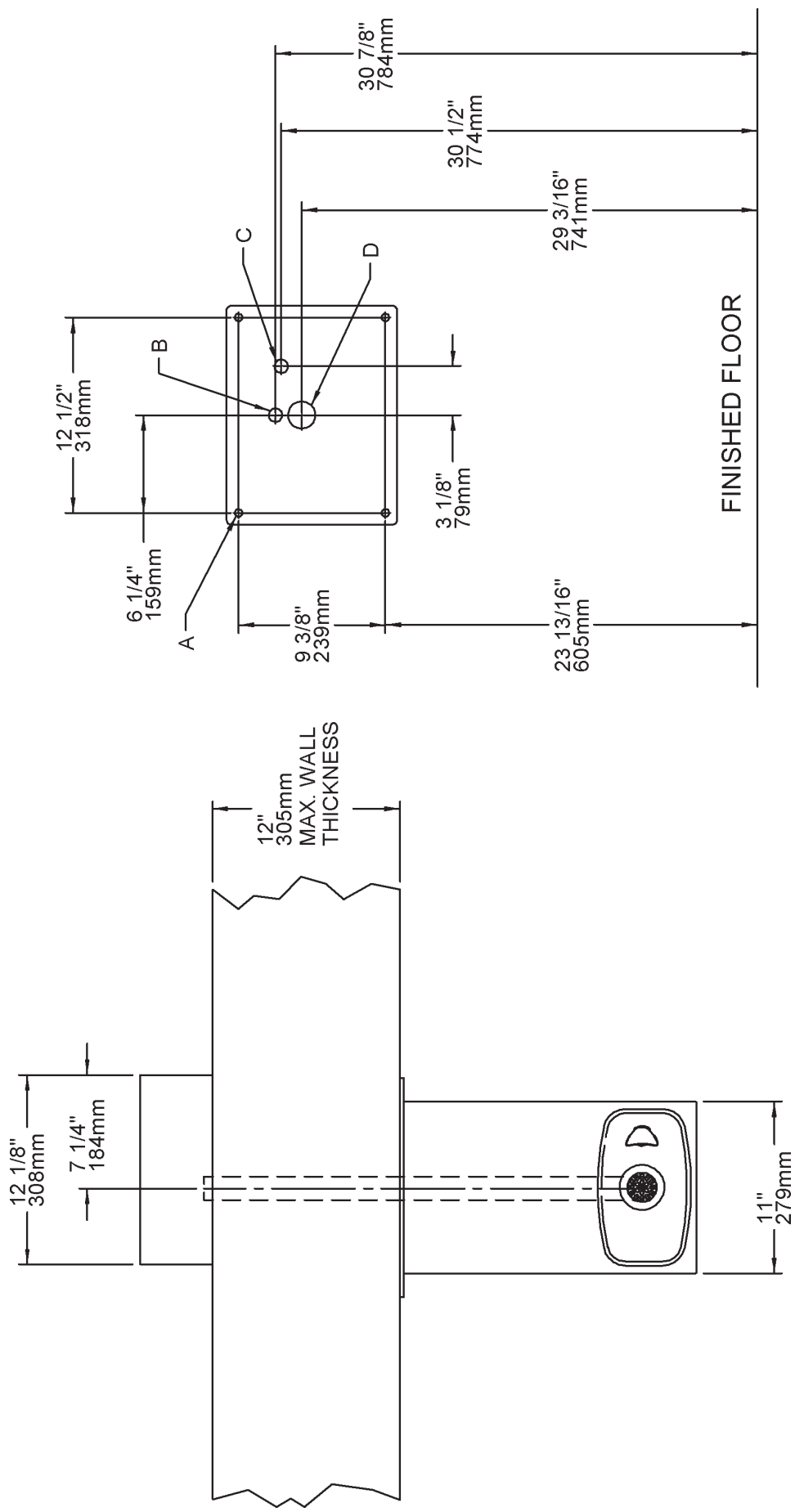
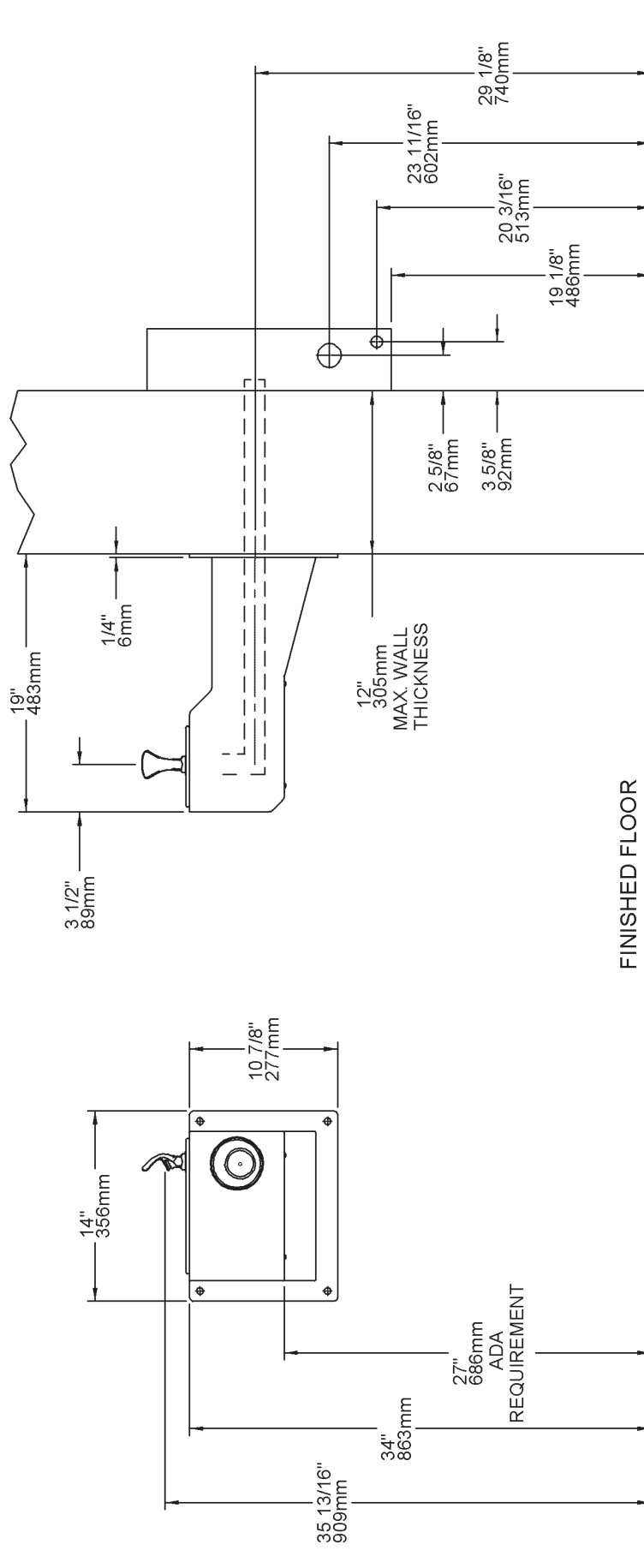

FIG. 1

LEGEND
 A = MOUNTING HOLE LOCATIONS (4), (1/2" DIA. BOLTS NOT PROVIDED).
 B = 7/8" DIA. (22mm) HOLE FOR WATER SUPPLY TUBE.
 C = 7/8" DIA. (22mm) HOLE FOR OPERATING CABLE.
 D = 1-3/4" DIA. (44mm) HOLE FOR WASTE LINE.

4705 FREEZE RESISTANT STEEL FOUNTAIN ROUGH-IN DRAWINGS

FIG. 2



1. **Wall should already be framed for the fountain using dimensions shown in Fig. 1.** Shown dimensions pertain to installation location. These dimensions are required for compliance with ANSI Standard A117.1 and ADA (Framing shown for reference only).
2. **Remove bottom cover from fountain and save screws.**
3. **Install the fountain** using bolts and washers (not provided). Tighten securely.
4. **Attach drain tube** to fountain and cut to required length using the freeze resistant box as a guide.
5. **Install freeze-resistant box** - see box instructions.
6. **Replace** bottom cover.

CABLE SHEATH ADJUSTMENT

To Increase Free Play

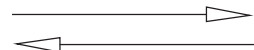

To Reduce Free Play

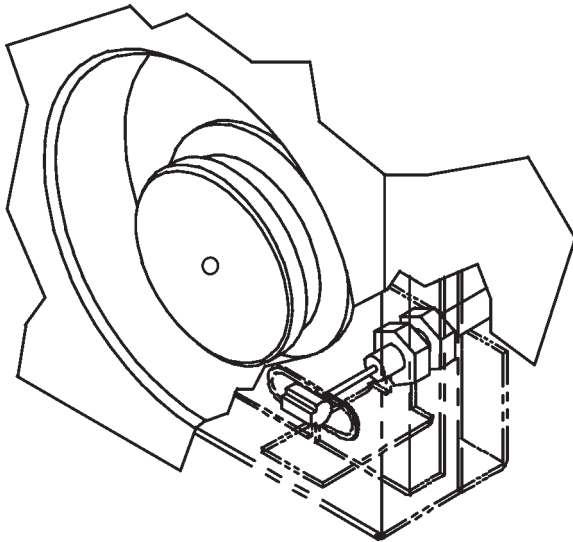

FIG. 3

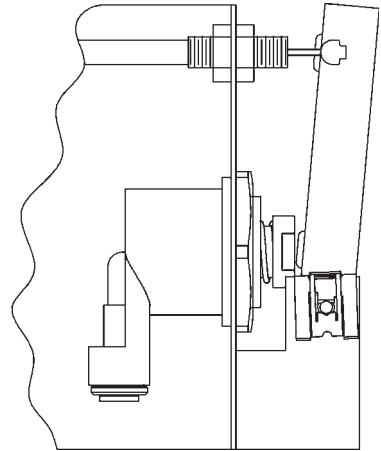

FIG. 4

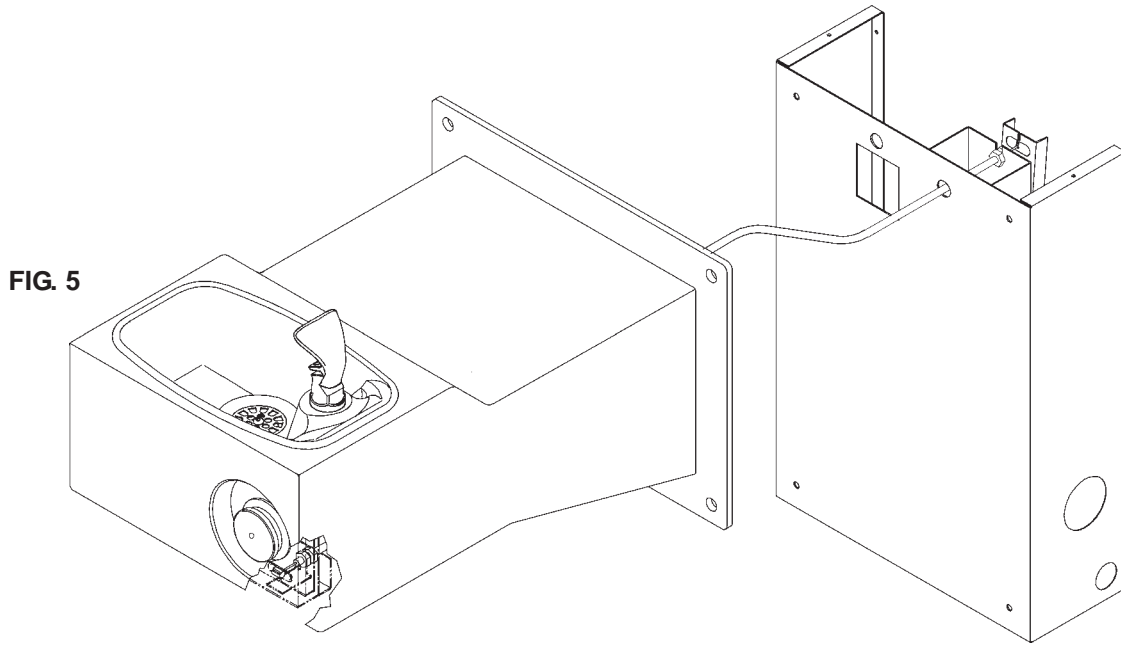

FIG. 5

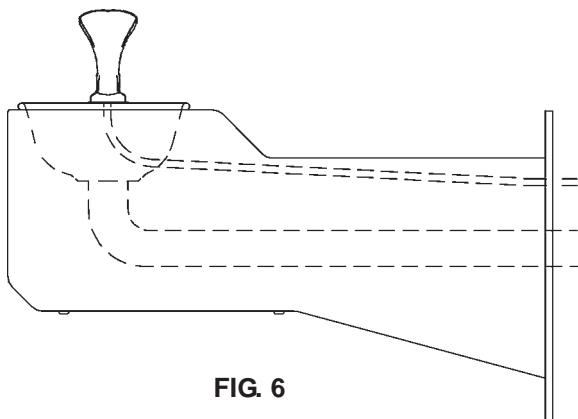

FIG. 6

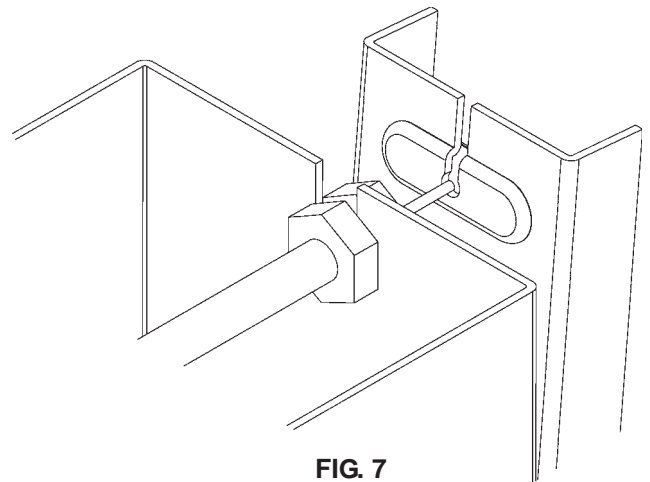

FIG. 7

4705 FR FTN

The freeze resistant package must be mounted on an interior wall in a heated area. The room temperature of the interior heated area must be 50° F (10° C) or higher. The freeze resistant package may be surface or recessed mounted. If recess mounted the surface of the cover must be flush with the interior wall surface. The package is furnished with screws for mounting the cover to the box. If the box is recess mounted, do not fasten the top and bottom of the cover to the box. Use the holes on the front only.

1. Assemble the operating cable to the fountain bracket. (Fountain should be mounted to exterior wall) Create a loop in the cable and thread the free end of the cable through the wall into the freeze resistant box. The adjustment nuts should be in the middle of threaded area on the operating cable. See Figure 7
2. Connect free end of operating cable to the valve-operating bracket. The end of the cables must be recessed into the indents on the pivot brackets.
3. Remove cable free play by adjusting the jam nuts on the ends of the operating cable. See Figure 4
4. Connect water line from fountain bubbler into freeze resistant box. The connection to the box uses a quick connect water fitting. Position the water line, in the fountain, to drain back into interior mounted box. Any water left standing, in the exterior line, can freeze. See Fig. 6

To insert tubing, push tube straight into fitting until it reaches a positive stop. To remove tubing from the fittings, relieve water pressure, push in on dark grey collar while pulling out on the tubing. See Figure 9

5. Connect drain and water supply lines to the freeze resistant fountain. Refer to Figure 1 for component positions. Inline strainer must be used on the inlet water line. See Fig. 8

Start-up

1. Turn on building water supply and check all connections for leaks. Repair as required.
2. Stream height is factory set at 35 PSI. If stream height needs to be changed adjust the regulator in the freeze resistant package. Clockwise adjustment raises stream height, counter clockwise adjustment will lower stream.
3. Adjust operating cable as required. Cable system should have a minimal amount of free play to allow for proper valve operation. If the system is too tight the valve will stay in the on position creating constant water flow. Too much free play will result in non-operation of the valve with the push-buttons.
4. Note: Water from the drain back tube in the freeze resistant package, will continue to run while the valve is actuated.
5. After cable system is adjusted properly stuff flexible insulation into any openings between the outside wall and the interior box.
6. Recheck all connections. If all connections are leak free replace cover(s) on the freeze resistant box(es) and fountain(s).

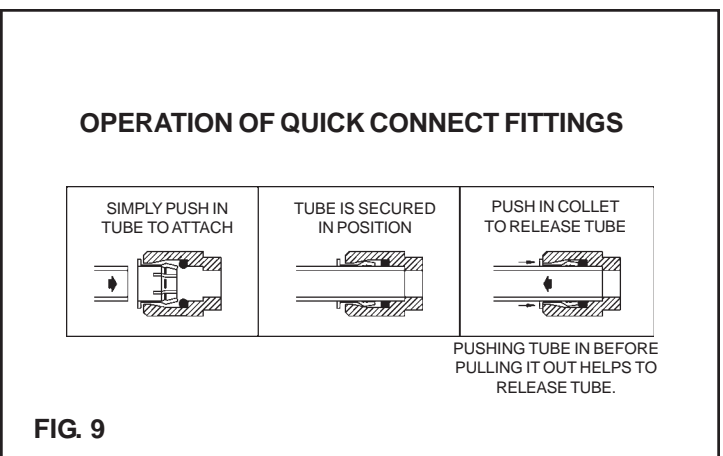
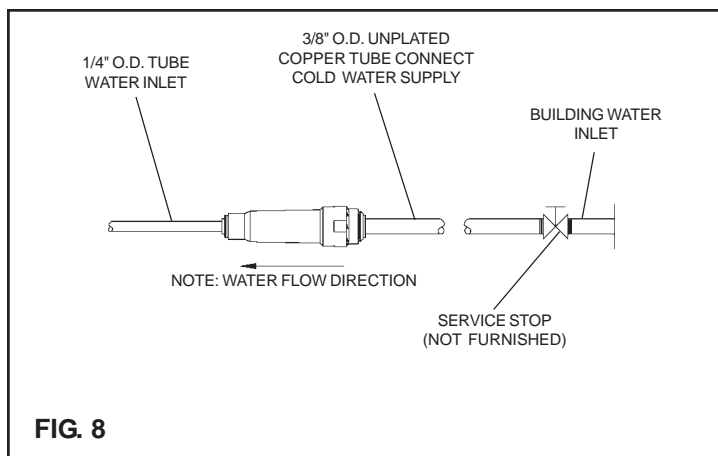

ITEMIZED PARTS LIST

ITEMNO.	PART NO.	DESCRIPTION
1	100147140560	Drain Gasket
2	100322740560	Gasket
3	101570540560	Drain Gasket
4	110544942550	Set Screw #8-32 X .125
5	110868642550	Socket Head Screw #10-24 x .75
6	160270508640	Strainer Plate
7	55919C	Push Button Extension
8	170705042830	Basin
9	28091C	Nameplate Insert
10	45662C	Push Button
11	45663C	Push Button Sleeve
12	45851C	Bubbler - Vandal Resistant
13	40045C	Hex Nut 1-5/16-20UN-2B
14	45827C	Fountain Body
15	45842C	Access Panel
16	27945C	Basin Bracket
17	27946C	Basin Pivot Bracket
18	56121C	Drain Elbow 1-1/4"
19	75588C	Slip Joint Nut 1-1/4"
20	51468C	Bumper - Reg. Valve Assy.
21	600985451640	Drain Plug
22	56092C	Tubing - Poly (Cut to Length)
23	15013C	Bubbler Tube Assy.
24	75534C	Pinned Torx Screw #10-24
25	75672C	Cap Screw
26	70793C	Elbow Fitting 1/4" x 90°
27	75589C	Seal Washer
28	70425C	Pivot Rod
29	50198C	Snap Bushing
30	40206000	Retainer
NS	75520C	Torx Bit T-25
NS	75596C	Paint Touch-up (Pen)

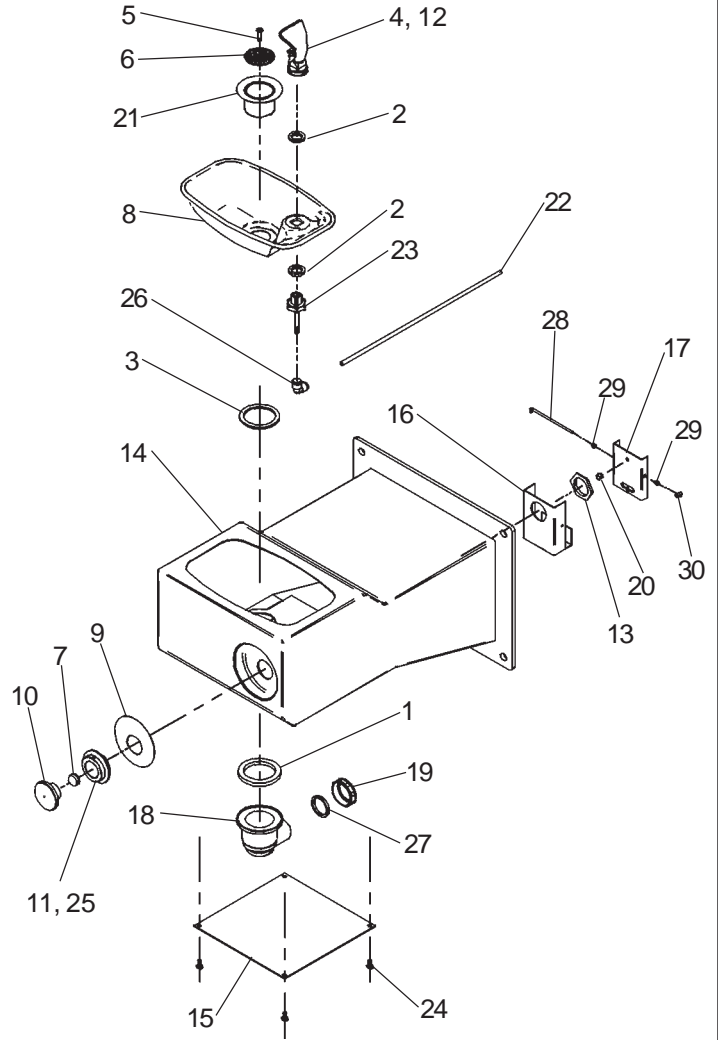

FIG. 10

Touch-up Paint

For minor scratches a Touch-up Paint Stick is available. For repairing large defects, off-the-shelf aerosol paint from your local hardware store can be used. Listed are two suggested brandnames.

- Brandname: X-O
XO-11 Hunter Green
- Brandname: Ace Hardware
Rust Stop / Machine & Implement
International Green

TROUBLE SHOOTING AND MAINTENANCE

Orifice Assy: Mineral deposits on orifice can cause water flow to spurt or not regulate. Mineral deposits may be removed from the orifice with a small round file not over 1/8" diameter or small diameter wire. **CAUTION: DO NOT** file or cut orifice material.

Stream Height Adjustment: Stream height is factory set at 35 PSI. If supply pressure varies greatly from this, adjust screw on regulator in Freeze Resistant Box. Clockwise adjustment will raise stream and counter-clockwise adjustment will lower stream. For best adjustment, stream should hit basin approx. 6-1/2" from bubbler.

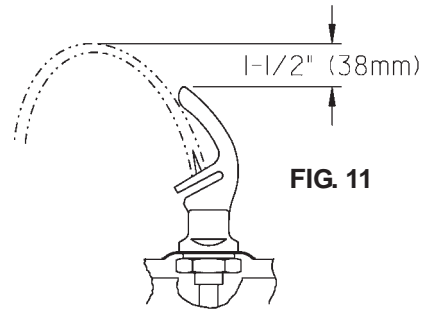

FIG. 11

Halsey Taylor
2222 CAMDEN COURT
OAK BROOK, IL 60523

www.DrinkingFountainDoctor.com

800-518-5388