

# MODELS BFC4F-2, BFC4FS-2, BFC7F-2 and BFC7FS-2

## BFC4F-2, BFC4FS-2, BFC7F -2 and BFC7FS-2 PART LIST

REF NO.	PART NUMBER	DESCRIPTION	BFC4F-2	BFC4FS-2	BFC7F-2	BFC7FS-2
1	10-14228-31-640	Projector	X	X	X	X
2	10-03227-40-560	Projector Gasket (2 required)	X	X	X	X
3	16-42252-16-550	Projector Nipple (included on item 32)	X	X	X	X
4	60-15172-51-550	Regulator Assembly*	X	X	X	X
4a	60-15173-51-550	Valve Assembly *(included in item 4)	X	X	X	X
4b	60-08050-51-550	Diaphragm Repair Kit* (for item 4a)	X	X	X	X
4c	60-15168-51-550	Push Button Assembly* (included in item 4)	X	X	X	X
4d	92445C	Push Button Repair Kit* (for item 4c)	X	X	X	X
5	10-15140-31-560	Valve Bracket	X	X	X	X
6	11-15160-43-890	Cotter Pins	X (2)	X (4)	X (2)	X (4)
7	10-15141-31-560	Front Push Bar	X	X	X	X
8	10-15144-31-560	Side Push Bar (2 each)		X		X
9	40-15151-43-730	Push Bar Lever (2 each)		X		X
10	10-15143-31-640	Front Push Bar Insert (2 each)	X	X	X	X
11	10-15145-31-560	Side Push Bar Insert (2 each)		X		X
12	11-14117-43-620	Hex Nut	X (4)	X (8)	X (4)	X (8)
13	13-15066-31-920	Name Plate (not shown)	X	X	X	X
14	17-15095-42-590	Receptor	X	X	X	X
15	11-26275-43-890	Receptor Screws (8 each)	X	X	X	X
16	10-26399-31-640	Drain Plug	X	X	X	X
17	16-02705-08-640	Strainer Plate	X	X	X	X
18	10-01471-40-560	Waste Gasket	X	X	X	X
19	60-15994-51-550	Waste Assembly	X	X	X	X
20	19-42339-51-550	Temperature Control	X	X	X	X
21	60-15528-51-550	Chiller	X	X	X	X
22	60-26833-51-550	Compressor Assembly	X	X	X	X
22a	19-26930-82-550	Relay/Overload (included in item 22)	X	X	X	X
23	10-10800-51-550	Drier	X	X	X	X
24	19-14761-51-550	Fan Motor	X	X	X	X
25	10-42095-43-870	Fan Blade	X	X	X	X
26	40-14705-43-730	Fan Mounting Bracket	X	X	X	X
27	40-15147-31-560	Fan Shroud	X	X	X	X
28	19-15175-51-550	Condenser	X	X	X	X
29	10-06876-08-640	Glass Filler Button	X	X	X	X
30	19-26686-51-550	Wiring Assembly	X	X	X	X
31	60-26730-51-550	Projector Service Line	X	X	X	X
32	60-26850-51-550	Valve to Chiller Line	X	X	X	X
33	60-15999-51-550	Inlet Supply Line	X	X	X	X
34	40-15139-43-XXX	Upper Front Panel	X	X	X	X
35	40-42097-43-XXX	Lower Front Panel	X	X	X	X
36	40-42096-43-XXX	Rear Side Panel (2 required) (not shown)	X	X	X	X
37	40-15136-43-XXX	Upper Right Hand Side Panel (not shown)	X		X	
37	40-15132-43-XXX	Upper Right Hand Side Panel (not shown)		X		X
38	40-15138-43-XXX	Upper Left Hand Side Panel (not shown)	X		X	
38	40-15133-43-XXX	Upper Left Hand Side Panel (not shown)		X		X
39	40-26838-43-730	Bottom/Back Panel (not shown)	X	X	X	X
40	11-10083-43-890	Panel Screws (38 each)	X	X	X	X
41	10-15431-51-550	Back Bumper	X	X	X	X
42	11-15430-43-890	Back Bumper Screws (2 each)	X	X	X	X
43	40-06609-43-730	Hanger Bracket (not shown)	X	X	X	X
44	40-12069-43-730	Dispenser Bottom Panel	X	X	X	X
45	29-15163-16-550	Capillary Tube	X	X	X	X
46	10-15146-31-560	Black Front Bumper	X	X	X	X
47	11-15201-43-890	Front Bumper Screws (2 each)	X	X	X	X

### ACCESSORIES AVAILABLE

Glass Fillers – See Spec Book

Glass Filler Installation Kit – 73-26589-51-550

Vandal Proof Kit – 73-15243-51-640\*

Water Filtration Kit – 73-15242-51-550\* (installed external to cooler)

73-15423-51-550\* (installed inside cooler)

XXX Please specify color when ordering. See Color Chart on page I-A for colors available.

\*See Detailed Parts Section for further breakdown.

# MODELS BFC4F-2, BFC4FS-2, BFC7F-2 and BFC7FS-2

MODEL#	MFG DATE S/N ENDING	COLD WATER CAP*	COMP HP	VOLTAGE ± 10	PH	HZ	TOTAL AMPS	R-12 REFRIG CHARGE*	WATER INLET PSIG
BFC4F-2	H88 - M90	4GPH	1/5	115	1	60	3.5	7.25 oz	20-90
BFC4FS-2	H88 - M90	4GPH	1/5	115	1	60	3.5	7.25 oz	20-90
BFC7F-2	H88 - M90	7GPH	1/5	115	1	60	3.5	7.25 oz	20-90
BFC7FS-2	H88 - M90	7GPH	1/5	115	1	60	3.5	7.25 oz	20-90

HEIGHT: 21 1/16"

WIDTH: 18"

DEPTH: 18 1/2"

\*ARI Ratings: capacity at GPH cooled to 50° with 90°F ambient temperature and 80°F inlet water.

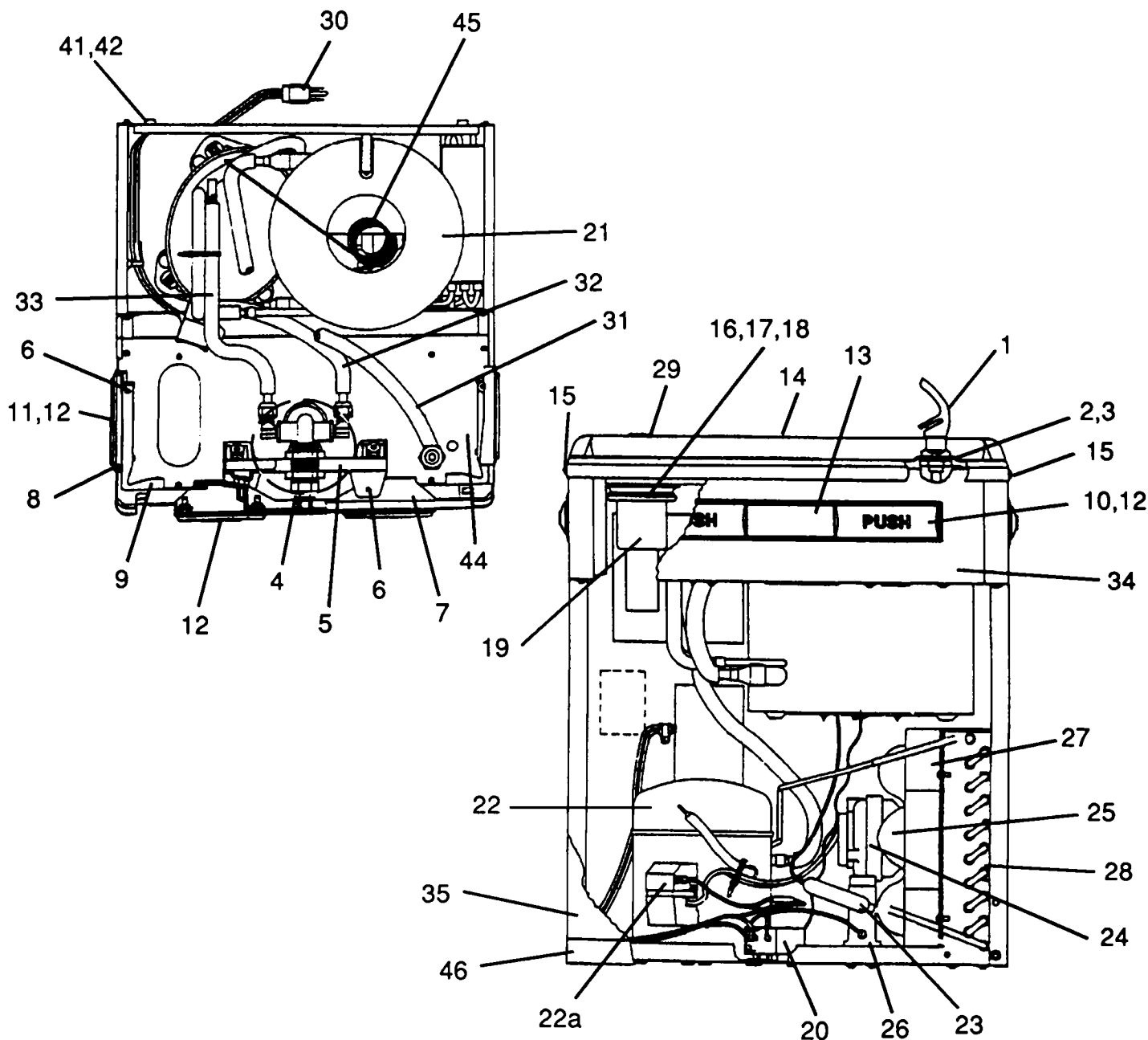

To order parts, contact your nearest Halsey Taylor wholesaler or representative.

Continued product improvement makes specifications subject to change without notice.

*Halsey Taylor.*