

MODELS BFC4F, BFC4FS, BFC7F and BFC7FS

BFC4F, BFC4FS, BFC7F and BFC7FS PART LIST

REF NO.	PART NUMBER	DESCRIPTION	BFC4F	BFC4FS	BFC7F	BFC7FS
1	10-14228-31-640	Projector	X	X	X	X
2	10-03227-40-560	Projector Gasket (2 required)	X	X	X	X
3	10-14224-31-550	Projector Nipple	X	X	X	X
4	60-15172-51-550	Regulator Assembly*	X	X	X	X
4a	60-15173-51-550	Valve Assembly *(included in item 4)	X	X	X	X
4b	60-08050-51-550	Diaphragm Repair Kit* (for item 4a)	X	X	X	X
4c	60-15168-51-550	Push Button Assembly* (included in item 4)	X	X	X	X
4d	92445C	Push Button Repair Kit* (included in item 4c)	X	X	X	X
5	10-15140-31-560	Valve Bracket	X	X	X	X
6	11-15160-43-890	Cotter Pins	X (2)	X (4)	X (2)	X (4)
7	10-15141-31-560	Front Push Bar	X	X	X	X
8	10-15144-31-560	Side Push Bar (2 each)		X		X
9	40-15151-43-730	Push Bar Lever (2 each)		X		X
10	10-15143-31-640	Front Push Bar Insert (2 each)	X	X	X	X
11	10-15145-31-560	Side Push Bar Insert (2 each)		X		X
12	11-14117-43-620	Hex Nut	X (4)	X (8)	X (4)	X (8)
13	13-15066-31-920	Name Plate	X	X	X	X
14	17-15095-42-590	Receptor	X	X	X	X
15	11-26275-43-890	Receptor Screws (8 each)	X	X	X	X
16	10-26399-31-640	Drain Plug	X	X	X	X
17	16-02705-08-640	Strainer Plate	X	X	X	X
18	10-01471-40-560	Waste Gasket	X	X	X	X
19	60-15170-51-550	Waste Assembly	X	X	X	X
20	19-42339-51-550	Temperature Control	X	X	X	X
21	60-15038-51-550	Chiller	X	X	X	X
22	60-15297-51-550	Compressor Assembly	X	X	X	X
22a	19-15166-51-550	Relay	X	X	X	X
22b	19-15165-51-550	Overload	X	X	X	X
23	10-10800-51-550	Drier	X	X	X	X
24	19-14761-51-550	Fan Motor	X	X	X	X
25	10-42095-43-730	Fan Blade	X	X	X	X
26	40-14705-43-730	Fan Mounting Bracket	X	X	X	X
27	10-15147-31-560	Fan Shroud	X	X	X	X
28	19-15175-51-550	Condenser	X	X	X	X
29	10-06876-08-640	Glass Filler Button	X	X	X	X
30	19-26686-51-550	Wiring Assembly	X	X	X	X
31	40-15139-43-XXX	Upper Front Panel	X	X	X	X
32	40-42097-43-XXX	Lower Front Panel (not shown)	X	X	X	X
33	40-42096-43-XXX	Rear Side Panel (2 required) (not shown)	X	X	X	X
34	40-15136-43-XXX	Upper Right Hand Side Panel (not shown)	X		X	
34	40-15132-43-XXX	Upper Right Hand Side Panel (not shown)		X		X
35	40-15138-43-XXX	Upper Left Hand Side Panel (not shown)	X		X	
35	40-15133-43-XXX	Upper Left Hand Side Panel (not shown)		X		X
36	40-26838-43-730	Bottom/Back Panel (not shown)	X	X	X	X
37	11-10083-43-890	Panel Screws (38 each)	X	X	X	X
38	10-15431-51-550	Back Bumper (2 each)	X	X	X	X
39	11-15430-43-890	Back Bumper Screws (2 each)	X	X	X	X
40	40-06609-43-730	Hanger Bracket (not shown)	X	X	X	X
41	40-12069-43-730	Dispenser Bottom Panel	X	X	X	X
42	29-15163-16-550	Capillary Tube	X	X	X	X
43	10-15146-31-560	Front Bumper (not shown)	X	X	X	X
44	11-15201-43-890	Front Bumper Screws (2 each)	X	X	X	X

ACCESSORIES AVAILABLE

Glass Fillers – See Spec Book

Glass Filler Installation Kit – 73-15240-51-550

Vandal Proof Kit – 73-15243-51-640*

Water Filtration Kit – 73-15242-51-550* (installed external to cooler)

73-15423-51-550* (installed inside cooler)

XXX Please specify color when ordering. See Color Chart on page I-A for colors available.

*See Detailed Parts Section for further breakdown.

MODELS BFC4F, BFC4FS, BFC7F and BFC7FS

MODEL#	MFG DATE S/N ENDING	COLD WATER CAP*	COMP HP	VOLTAGE ± 10	PH	HZ	TOTAL AMPS	R-12 REFRIG CHARGE*	WATER INLET PSIG	
BFC4F	H87 and older	4GPH	1/5	115	1	60	4.5	7.25 oz	20-90	
BFC4FS	H87 and older	4GPH	1/5	115	1	60	4.5	7.25 oz	20-90	
BFC7F	H87 and older	7GPH	1/5	115	1	60	4.5	7.25 oz	20-90	
BFC7FS	H87 and older	7GPH	1/5	115	1	60	4.5	7.25 oz	20-90	
HEIGHT: 21 1/16"			WIDTH: 18"				DEPTH: 18 1/2"			
*ARI Ratings: capacity at GPH cooled to 50° with 90°F ambient temperature and 80°F inlet water.										

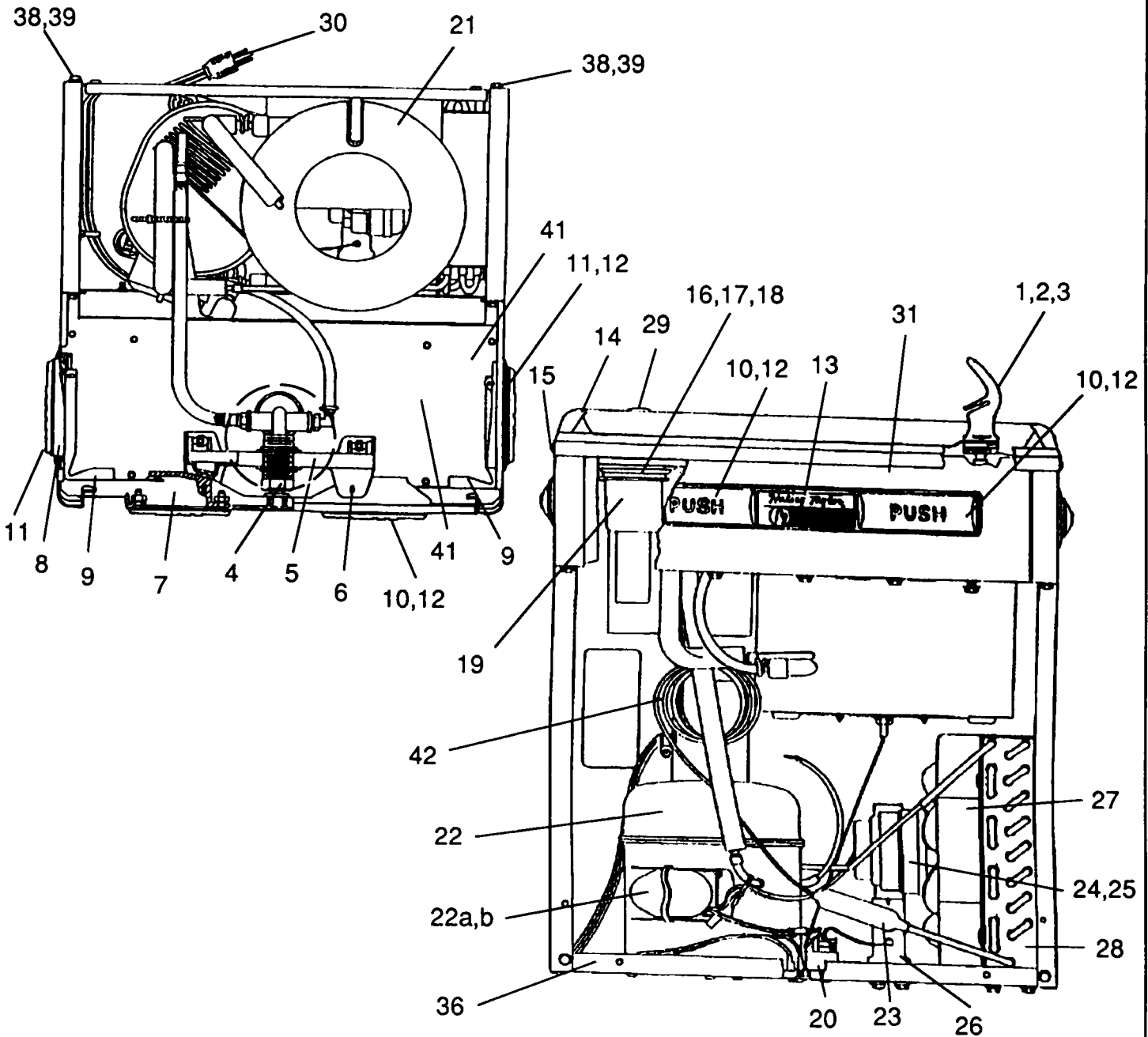

To order parts, contact your nearest Halsey Taylor wholesaler or representative.

Continued product improvement makes specifications subject to change without notice.

Halsey Taylor.