

HAC8F(S)BL-Q*1A
HALSEY TAYLOR OWNERS MANUAL
 USES HFC-134A REFRIGERANT

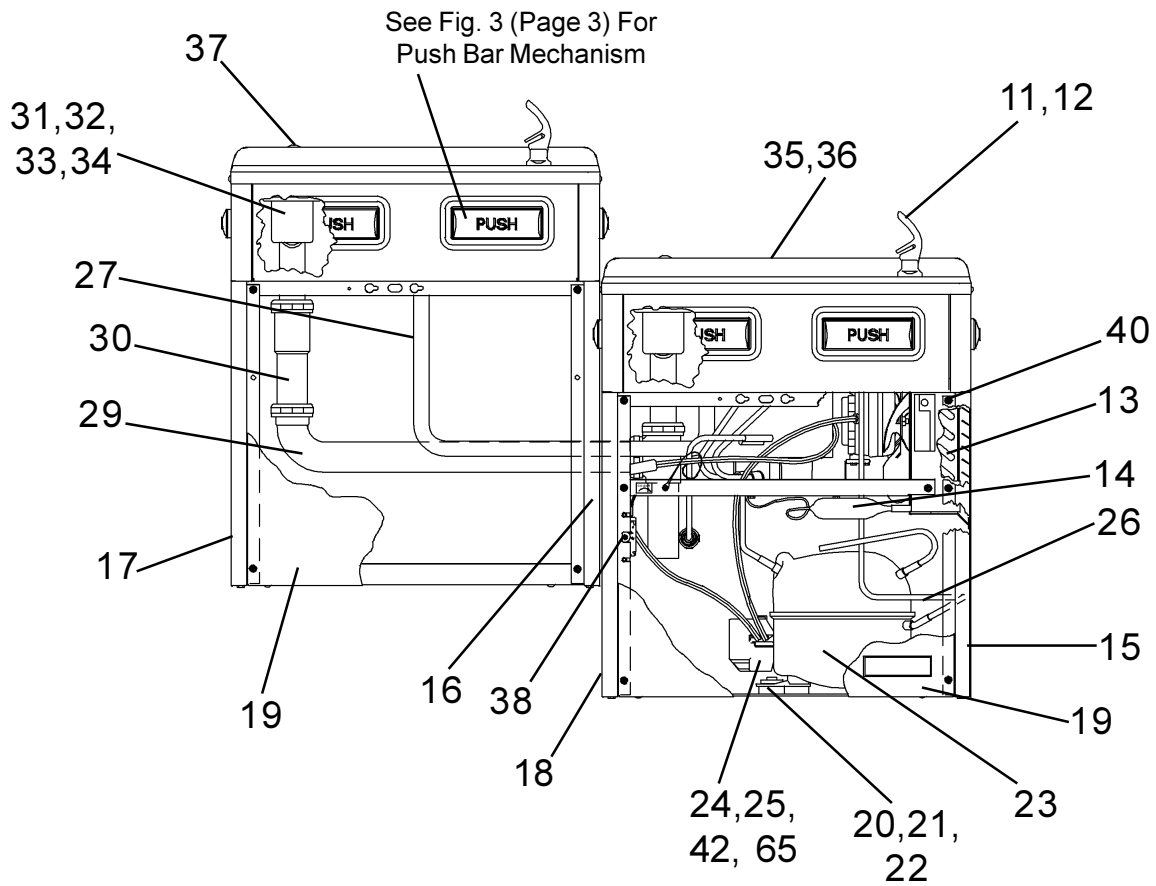

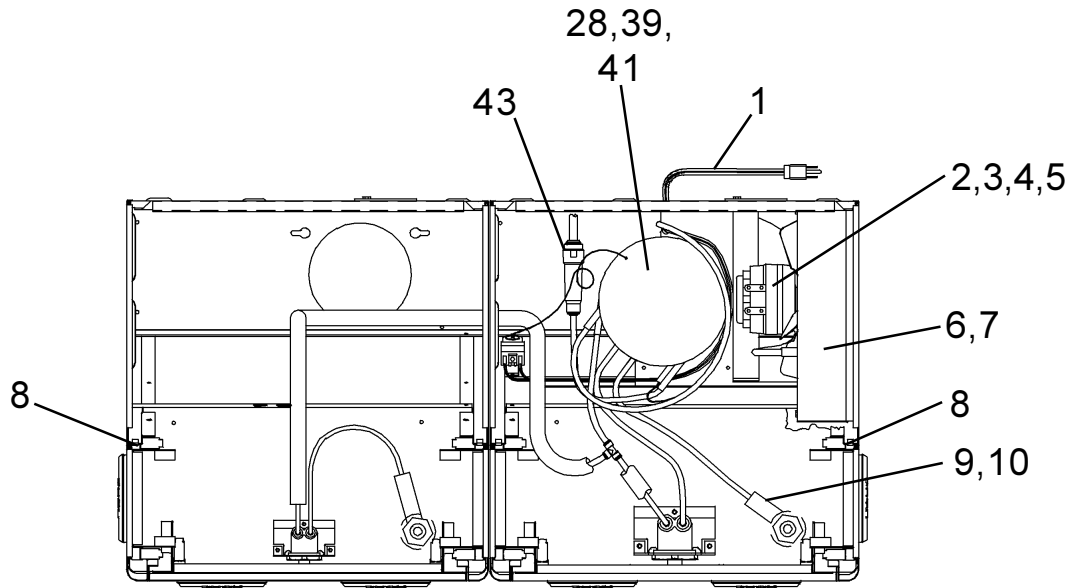
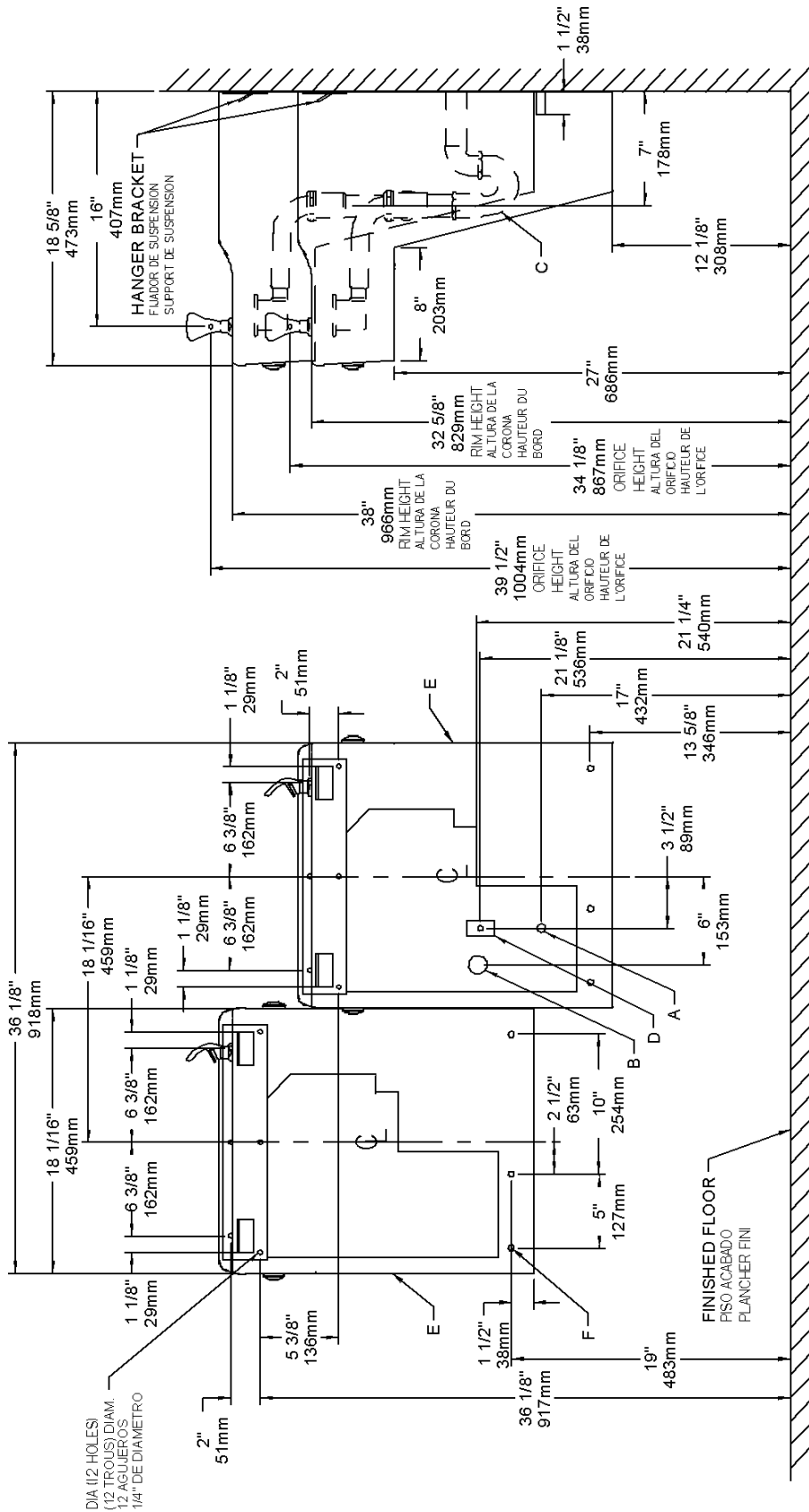

FIG. 2

LEGEND/LEYENDA/LÉGENDE
A = RECOMMENDED WATER SUPPLY LOCATION 3/8 O.D. UNPLATED COPPER TUBE CONNECT STUB 1-1/2 IN. (38 mm) OUT FROM WALL SHUT OFF BY OTHERS
 SE RECOMIENDA UBICAR EL TUBO CORTO DE CONEXIONAL TUBO DE COBRE SIN CHAPAR DE 3/8" DE DIAM. EXT. A 1-1/2" (38 mm) FUERA DE LA LAVE DE PASEO EN LA PARED COLOCADA POR TERCEROS
 EMPACEMENT RECOMMANDÉ D'ALIMENTATION EN EAU PAR TUBE EN CUIVRE NON PLAQUÉ DE 3/8 PO. (9.5 mm) D.E. CONNECTANT UNE TUYAUTERIE DE 1-1/2 PO. (38 mm) DEPUIS LE ROBINET D'ARRÊT FOURNI PAR D'AUTRES.

B = RECOMMENDED LOCATION FOR WASTE OUTLET 1-1/4" O.D. DRAIN
 UBICACIÓN RECOMENDADA PARA EL DRENAJE DE SALIDA DE AGUA DE 1 1/4" DE DIAMETRO.
 EMPACEMENT RECOMMANDÉ POUR LE DRAIN DE D.E. 1-1/4" DE SORTIE D'EAU.

C = 1-1/4 TRAP NOT FURNISHED**
 PURGADOR DE 1 1/4 NO PROPORCIONADO**
 SIPHON 1-1/4 NON FOURNI**

D = ELECTRICAL SUPPLY (3) WIRE RECESSED BOX
 CAJA RECESIVADE ALAMBRES (3) DE SUMINISTRO ELÉCTRICO
 BOITE ENCASTRÉE D'ALIMENTATION ÉLECTRIQUE (3) FILS

E = INSURE PROPER VENTILATION BY MAINTAINING 6" (152 mm) (MIN.) CLEARANCE FROM CABINET LOUVERS TO WALL.
 ASEGURE UNA VENTILACIÓN ADECUADA MANTENIENDO UN ESPACIO E 6" (152 mm) (MIN.) DE HOLGURA ENTRE LA REJILLA DE VENTILACIÓN DEL MUEBLE Y LA PARED
 ASSUREZ VOS UNE BONNE VENTILATION EN GARDANT 6" (152 mm) (MIN.) ENTRE LES ÉVÉNENTS DE L'ENCEINTE ET LE MUR.

F = 7/16 BOLT HOLES FOR FASTENING UNIT TO WALL
 AGUJEROS DE LAS TUERCAS DE 7/16 PARA SUJETAR LA UNIDAD A LA PARED
 TROUS D'ÉCROUS 7/16 POUR FIXER L'APPAREIL AU MUR

*ADA REQUIREMENT
 *REQUISITO DE A.D.A.
 *EXIGENCE ADA

**When replacing a Model "BFC" with a new unit Model "HAC", installer must cut 1-1/2 inches from length of cooler waste line before connecting to trap (see installation instruction No. 7)

**Cuando reemplaza un Modelo "BFC" con una unidad nueva Modelo "HAC", el instalador deberá cortar 1 1/2 pulgadas del largo del tubo de desague del enfriador antes de conectar al purgador (vea las instrucciones de instalación No. 7)

**En remplaçant un modèle "BFC" avec un nouveau modèle "HAC", l'installateur doit couper 1 1/2 pouce de longueur de la canalisation résiduaire du refroidisseur avant de le raccorder au siphon (voir instruction d'installation no. 7)

PUSH BAR MECHANISM

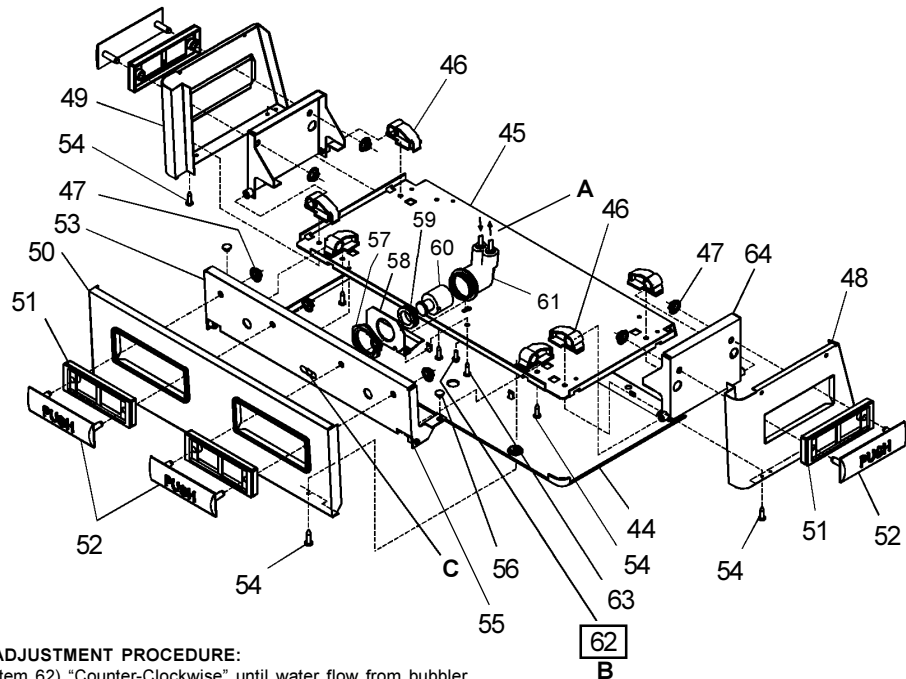

FIG. 3

Water Valve Mechanism - ADJUSTMENT PROCEDURE:

- Turn adjustment screw (Item 62) "Counter-Clockwise" until water flow from bubbler starts.
- Turn adjustment screw "Clockwise" until water flow stops, THEN turn an additional 1/2 turn.

NOTE: Adjustments stated above are viewed from underneath unit (bottom side of dispenser panel Item 45)

NOTE: If continuous flow occurs at the end of the compressor cycle, turn cold control (Item 38) counterclockwise 1/4 turn.

LEGEND

- A) Note: Water flow direction
- B) Adjust this screw to eliminate mechanism "Free Play" or continuous flow from bubbler conditions. (See ADJUSTMENT PROCEDURE)
- C) Stream height adjustment (see note #8)

**IMPORTANT
ALL SERVICE TO BE PERFORMED BY AN
AUTHORIZED SERVICE PERSON**

CAUTION: Cleaning of Aztec Gold Models requires special care. Outer surfaces must be cleaned with a mild detergent or mixture of vinegar and water only, rinsed and wiped dry. Abrasive and acidic cleaners may eventually damage the Aztec Gold finish.

**HANGER BRACKETS & TRAP
INSTALLATION**

- 1) Remove hanger bracket fastened to back of cooler by removing one (1) screw.
 - 2) Mount the hanger bracket and trap as shown in Figure 2.
- NOTE:** Hanger Bracket **MUST** be supported securely. Add fixture support carrier if wall will not provide adequate support.

IMPORTANT:

- 7 in. (178mm) dimension from wall to centerline of trap must be maintained for proper fit.
 - Anchor hanger securely to wall using all six (6) 1/4 in. dia. mounting holes.
- 3) Install straight valve for 3/8" O.D. tube.

INSTALLATION OF COOLER

- 4) Hang the cooler on the hanger bracket. Be certain the hanger bracket is engaged properly in the slots on the cooler back as shown in Fig. 4.
- 5) Loosen the two (2) screws holding the lower front panel at the bottom of cooler base and two (2) screws at the top. Remove the front panel and set aside.
- 6) Connect water inlet line--See Note 4 of General Instructions.
- 7) Remove the slip nut and gasket from the trap and install them on the cooler waste line making sure that the end of the waste line fits into the trap. Assemble the slip nut and gasket to the trap and tighten securely.

STARTUP

Also See General Instructions

- 8) Stream height is factory set at 45-50 PSI. If supply pressure varies greatly from this, readjust stream height to approximately 1-1/2" (38mm) above the bubbler guard by turning adjustment screw, accessible by removing front push panel, Item No. 51 (see Fig. 3 & 5).
- 9) Replace the front panel and secure by retightening four (4) screws.
- 10) If a taste, odor or sediment problem is prevalent, try installing our water filter module, part no 73-15242-51-550

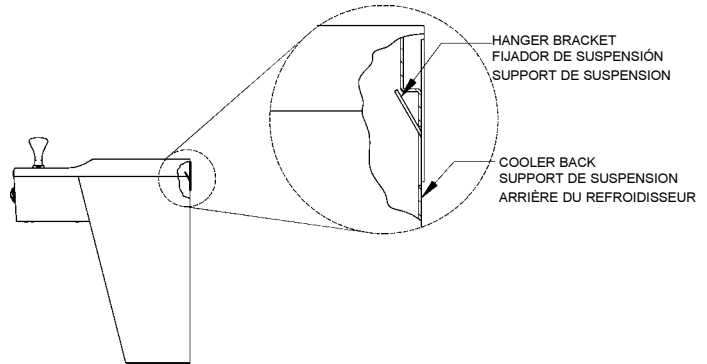
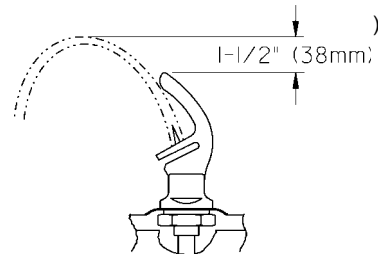

FIG. 4



CORRECT STREAM HEIGHT

FIG. 5

ITEMIZED PARTS LIST

ITEM NO	PART NO	DESCRIPTION
1	31517C	Power Cord
2, 2a	30699C	Fan Blade
2b	30664C	Fan Blade
3	70018C	Hex Nut - Fan Blade
4, 4a	31490C	Fan Motor
4b	31491C	Fan Motor
5	70009C	Screw - (Fan Motor)
6	22899C	Shroud - Fan
7	38417001	Screw - #8-18 x 3/8" Lg. (Fan Shroud)
8	70241C	Clip (Front and Rear Panels)
9	62296C	Tube Assembly - Bubbler
10	10079C	Nipple - Bubbler (included with Item No. 9)
11	51544C	Bubbler - Chrome
	45396C	Bubbler - Aztec Gold
12	10-03227-40-560	Gasket - Bubbler (upper and lower)
13	62152C	Condenser
14	66202C	Drier
15	See Color Table	Panel - Right Rear (Refrig. Unit)
16	See Color Table	Panel - Right Rear (Left Unit)
17	See Color Table	Panel - Left Rear (Left Unit)
18	See Color Table	Panel - Left Rear (Refrig. Unit)
19	See Color Table	Panel - Front Lower
20	10-15161-43-550	Stud - Compressor Mtg.
21	10-08067-40-570	Grommet - Compressor Mtg.
22	19037000	Clip - Compressor Mtg.
23*	35767C	Compressor Serv. Pak FF7,5HBK
23a*	35761C	Compressor Serv. Pak FF6HBK
23b*	35807C	Compressor Serv. Pak AE3425Y
23c*	35947C	Compressor Serv. Pak EM65
24	31025C	Overload /Relay 1.350.358
24a	31026C	Overload /Relay 1.350.356
24b	35801C	Relay 9660-042-166
24c	35795C	Overload MRP26ALL-69
24d	31039C	Overload/Relay P600B/427NFBYY
25, 25a	35766C	Cover - Relay
25b	30181C	Cover - Terminal
25b	30180C	Overload Spring
25b	30182C	Bale Strap
25c	35768C	Cover - Relay
26, 26b	66214C	Heat Exchanger
26a	66215C	Heat Exchanger
26c	66386C	Heat Exchanger
27	62198C	Tube - Cu. 1/4 x 36"
28	70836C	Elbow
29	40022C	Waste Line Assembly
30	16-07448-51-550	Tailpiece Assembly (Left Unit)
31	40590C	Waste Line Assembly
32	10-01471-40-560	Gasket - Drain
33	10-26399-31-640	Drain Plug - Chrome
	45413C	Drain Plug - Aztec Gold
34	16-02705-08-640	Strainer Plate - Chrome
	45400C	Strainer Plate - Aztec Gold
35	22893C	Basin - Stainless Steel
	27594C	Basin - Aztec Gold
36	11-26275-43-890	Screw - Basin Mtg. Stainless Steel
	75573C	Screw - Basin Mtg. Aztec Gold
37	10-06876-08-640	Plug Button - Chrome
	75571C	Plug Button - Aztec Gold
38	31513C	Cold Control
39	62220C	Evaporator Assembly
40	70002C	Screw - #10 x 1/2" Lg. HHSM
41	70767C	Clip - Evaporator Retaining
42	19-42439-01-550	Cover - Electrical Shield
43	55996C	Strainer
44	See Color Table	Cover - Dispenser Bottom
45	22897C	Panel - Bottom Dispenser
46	51531C	Block - Pivot
47	11-14117-43-620	Nut - 1/4 , Self-Threading
48	See Color Table	Panel - Right Side
49	See Color Table	Panel - Left Side
50	See Color Table	Panel - Front Push
51	55859C	Pushbar - Side & Front
52	55947C	Insert - Push Bar, Gray
	55948C	Insert - Push Bar, Brown
53	22900C	Bracket - Front Push
54	70864C	Screw - #8 x 5/8" Lg. Torx/Slot
55	50212C	Rivet - Drive Type
56	51667C	Bumper - Press Bar
57	40045C	Hex Nut
58	23003C	Bracket - Regulator Mounting
59	15005C	Retaining Nut
60	61314C	Regulator
61	50986C	Holder - Regulator
62	70935C	Screw - Shoulder x 1/2" Lg.
63	11-26275-43-890	Screw - Regulator Brkt. Mtg.
64	22901C	Bracket - Side Push
65c	35935C	Capacitor - Run
NS	40-06609-43-730	Hanger Bracket

COLOR TABLE					
PANEL COLOR	Item No. 15 Part No.	Item No. 16 Part No.	Item No. 17 Part No.	Item No. 18 Part No.	Item No. 19 Part No.
Almond Vinyl	22968C	26772C	22961C	26765C	22954C
Aztec Gold	27491C	27511C	27487C	27507C	27499C
Platinum Vinyl	22860C	26806C	22852C	26798C	22844C
Stainless Steel	22862C	26776C	22854C	26800C	22955C
Slate Vinyl	22864C	26810C	22856C	26802C	22848C

COLOR TABLE - PUSH BAR MECHANISM						
PANEL COLOR	Item No. 48 Part No. (w/o hole)	Item No. 48 Part No. (with hole)	Item No. 49 Part No. (w/o hole)	Item No. 49 Part No. (with hole)	Item No. 50 Part No.	Item No. 44 Part No.
Almond Vinyl	23016C	22947C	23009C	22940C	26848C	55931C
Aztec Gold	27503C	27483C	27433C	27479C	27596C	55930C
Platinum Vinyl	22820C	22836C	22812C	22828C	22804C	55931C
Stainless Steel	22822C	22838C	22814C	22830C	22806C	55931C
Slate Vinyl	22824C	22840C	22816C	22832C	22808C	55931C

*REPLACE WITH SAME COMPRESSOR USED IN ORIGINAL ASSEMBLY.
 NOTE: All correspondence pertaining to any of the above water coolers or orders for repair parts MUST include Model No. and Serial No. of cooler, name and part number of replacement part.



2222 CAMDEN COURT
 OAK BROOK, IL 60523
 630.574.3500

PRINTED IN U.S.A.