

FIG. 2

**LEGEND/LÉGENDE**  
**A = RECOMMENDED WATER SUPPLY LOCATION 3/8 O.D. UNPLATED COPPER TUBE CONNECT STUB 1-1/2 IN. (38 mm) OUT FROM WALL SHUT OFF BY OTHERS**  
 SE RECOMIENDA UBICAR EL TUBO CORTO DE CONEXIÓN AL TUBO DE COBRE SIN CHAPAR DE 3/8" DE DIAM. EXT. A 1-1/2" (38 mm) FUERA DE LA LLAVE DE PASO EN LA PARED COLOCADA POR TERCEROS  
 EMPLACEMENT RECOMMANDÉ D'ALIMENTATION EN EAU PAR TUBE EN CUIVRE NON PLAQUÉ DE 3/8 PO. (9,5 mm) D.E. CONNECTANT UNE TUYAUTERIE DE 1-1/2 PO. (38 mm) DEPUIS LE ROBINET D'ARRÊT FOURNI PAR D'AUTRES.

**B = RECOMMENDED LOCATION FOR WASTE OUTLET 1-1/2" O.D. DRAIN**  
 UBICACIÓN RECOMENDADA PARA EL DRENAJE DE SALIDA DE AGUA, DE 1-1/2" DE DIÁMETRO.  
 EMPLACEMENT RECOMMANDÉ POUR LE DRAIN DE D.E. 1-1/2" DE SORTIE D'EAU.

**C = 1-1/2" TRAP NOT FURNISHED\*\***  
 PURGADOR DE 1-1/2" NO PROPORCIONADO\*\*  
 SIPHON 1-1/2" NON FOURNI\*\*

**D = ELECTRICAL SUPPLY (3) WIRE RECESSED BOX**  
 CAJA RECESIVADA DE ALAMBRES (3) DE SUMINISTRO ELÉCTRICO  
 BOÎTE ENCASTRÉE D'ALIMENTATION ÉLECTRIQUE (3) FILS

**E = INSURE PROPER VENTILATION BY MAINTAINING 6" (152 mm) (MIN.) CLEARANCE FROM CABINET LOUVERS TO WALL.**  
 ASEGURE UNA VENTILACIÓN ADECUADA MANTENIENDO UN ESPACIO E 6" (152 mm) (MÍN.) DE HOLLGURA ENTRE LA REJILLA DE VENTILACIÓN DEL MUEBLE Y LA PARED  
 ASSUREZ-VOUS UNE BONNE VENTILATION EN GARDANT 6" (152 mm) (MÍN.) ENTRE LES ÉVÉNENTS DE L'ENCEINTE ET LE MUR.

**F = 7/16 BOLT HOLES FOR FASTENING UNIT TO WALL**  
 AGUJEROS DE LAS TUERCAS DE 7/16 PARASUJETAR LA UNIDAD A LA PARED  
 TROUS D'ÉCROUS 7/16 POUR FIXER L'APPAREIL AU MUR

\*ADA REQUIREMENT  
 \*REQUISITO DE A.D.A.  
 \*EXIGENCE ADA

\*\*When replacing a Model "BFC" with a new unit Model "HAC", install must cut 1-1/2 inches from length of cooler waste line before connecting to trap (see installation instruction No.7)  
 \*\*Cuando reemplace un Modelo "BFC" con una unidad nueva Modelo "HAC" el instalador deberá cortar 1 1/2 pulgadas del largo del tubo de desague del enfriador antes de conectar el purgador (vea las instrucciones de instalación No. 7)  
 \*\*En remplaçant un modèle "BFC" avec un nouveau modèle "HAC", l'installateur doit couper 1 1/2 pouce de longueur de la canalisation résiduaire du refroidisseur avant de le raccorder au siphon (voir instruction d'installation no. 7)

**PUSH BAR MECHANISM**

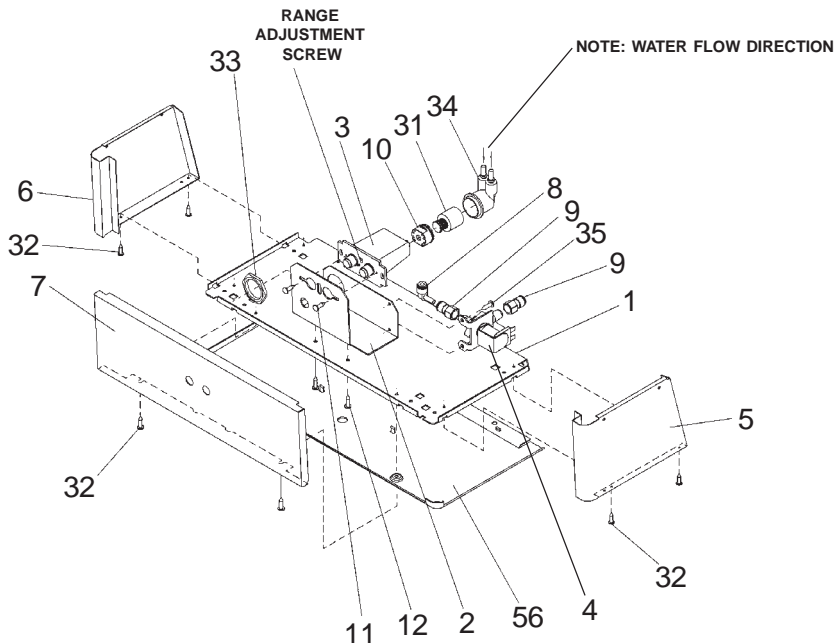

**FIG. 3**

**Sensor Control:** If sensor fails to operate valve mechanism or operates erratically, check the following.

- a. Ensure there are no obstructions within a 40-inch radius from front of cooler.
- b. Check wire connections at solenoid valve and sensor.
- CAUTION: Make sure unit is unplugged before checking any wiring.
- c. Ensure proper operation of solenoid valve. If there is an audible clicking sound yet no water flows, look for an obstruction in the valve itself or elsewhere in the water supply line.

**Sensor Range Adjustment:** The electronic sensor used in this cooler is factory pre-set for a "visual" range of 36 inches. If actual range varies greatly from this, or a different setting is desired, follow the range adjustment procedure below:

- a. Remove front panel of cooler.
- b. Using a small tip screwdriver, rotate range adjustment screw clockwise to increase range and counter-clockwise to decrease range. (See Fig. 3).
- CAUTION: Complete range of sensor (24-46 inches) is only one turn of the adjusting screw.
- c. Replace the front panel.

**IMPORTANT  
ALL SERVICE TO BE PERFORMED BY AN  
AUTHORIZED SERVICE PERSON**

**CAUTION:** To preserve the quality and keep this AZTEC GOLD finish clean and spot free, clean this surface with only mild detergent or window cleaner and polish with a soft cloth. DO NOT use any abrasive cleaners or harsh chemicals. They WILL damage the finish!

**HANGER BRACKETS & TRAP  
INSTALLATION**

- 1) Remove hanger bracket fastened to back of cooler by removing one (1) screw.
  - 2) Mount the hanger bracket and trap as shown in Figure 2.
- NOTE:** Hanger Bracket MUST be supported securely. Add fixture support carrier if wall will not provide adequate support.

**IMPORTANT:**

- 7 in. (178mm) dimension from wall to centerline of trap must be maintained for proper fit.
  - Anchor hanger securely to wall using all six (6) 1/4 in. dia. mounting holes.
- 3) Install straight valve for 3/8" O.D. tube.

**INSTALLATION OF COOLER**

- 4) Hang the cooler on the hanger bracket. Be certain the hanger bracket is engaged properly in the slots on the cooler back as shown in Fig. 4.
- 5) Loosen the two (2) screws holding the lower front panel at the bottom of cooler base and two (2) screws at the top. Remove the front panel and set aside.
- 6) Connect water inlet line--See Note 4 of General Instructions.
- 7) Remove the slip nut and gasket from the trap and install them on the cooler waste line making sure that the end of the waste line fits into the trap. Assemble the slip nut and gasket to the trap and tighten securely. Plug both power cords into duplex receptacle.

**START UP**

**Also See General Instructions**

- 8) Stream height is factory set at 45-50 PSI. If supply pressure varies greatly from this, readjust stream height to approximately 1-1/2" (38mm) above the bubbler guard by turning adjustment screw, accessible by removing front panel, Item No.7 (see Fig.3 & 5).
- 9) Replace the front panel and secure by retightening four (4) screws.

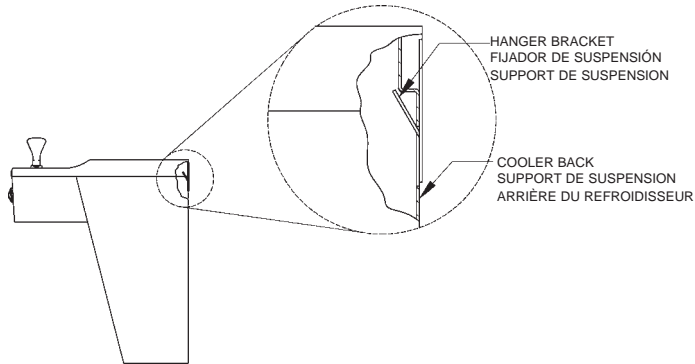

**FIG. 4**

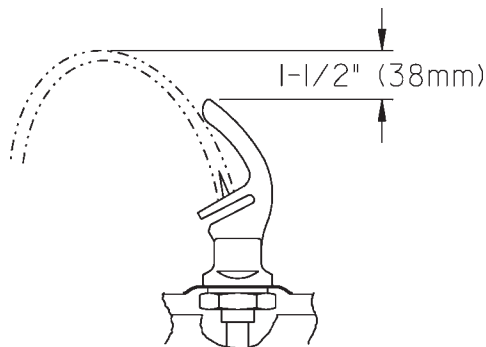

**CORRECT STREAM HEIGHT**

**FIG. 5**

ITEMIZED PARTS LIST

ITEMIZED PARTS LIST

ITEM NO	PART NO	DESCRIPTION	ITEM NO	PART NO	DESCRIPTION
1	22897C	Panel - Bottom Dispenser	33	40045C	Hex Nut
2	26729C	Bracket - Valve Mounting	34	50986C	Holder - Regulator
3	36028C	Sensor - Clear (115V)	35	70002C	Screw #10 x 1/2" Lg. HHSM
4	31272C	Solenoid Valve (115V)	36	101516143550	Stud - Compressor Mtg.
5	See Color Table	Panel - Right Side	37	100806740570	Grommet - Compressor Mtg.
6	See Color Table	Panel - Left Side	38	19037000	Clip - Compressor Mtg.
7	See Color Table	Panel - Front	39*	36094C	Compressor Serv. Pak EMI 70 HNR
8	70817C	Elbow 1/4 Stem x 1/4 O.D.	40	35959C	Relay
9	75507C	Fitting 1/4 NPTF x 1/4 O.D.	41	35768C	Cover - Relay
10	56082C	Nut - Regulator	42	36158C	Overload
11	70644C	Screw #6-32 x 1/2" Lg. PHMS	43	66576C	Heat Exchanger
12	75497C	Screw #10 x 1/2" Lg. PHSM	44	45351C	Waste Line Assembly
13	See Color Table	Panel - Right Rear (Refrig. Unit)	45	56121C	Fitting - Elbow 1-1/4
14	See Color Table	Panel - Front Lower	46	75588C	Nut - Slip Joint 1-1/4
15	See Color Table	Panel - Right Rear (Left Unit)	47	100147140560	Gasket - Drain
16	See Color Table	Panel - Left Rear (Left Unit)	48	102639931640	Drain Plug - Chrome
17	See Color Table	Panel - Left Rear (Refrig. Unit)		45413C	Drain Plug - Aztec Gold
18	31483C	Power Cord	49	160270508640	Strainer Plate - Chrome
19	30664C	Fan Blade		45400C	Strainer Plate - Aztec Gold
20	70018C	Hex Nut - Fan Blade	50	28152C	Basin - Stainless Steel
21	31490C	Fan Motor		27594C	Basin - Aztec Gold
22	70009C	Screw - (Fan Motor)	51	75634C	Screw - Basin Mtg. - Stainless Steel
23	56237C	Shroud - Fan		75605C	Screw - Basin Mtg. - Aztec Gold
24	56092C	Tubing - Poly (Cut To Length)	52	75589C	Gasket
25	75524C	Clip (Front and Rear Panels)	53	31513C	Cold Control
26	56159C	Nipple - Bubbler	54	66534C	Evaporator Assembly
27	51544C	Bubbler - Chrome	55	40022C	Waste Line Assembly
	45396C	Bubbler - Aztec Gold	56	See Color Table	Cover - Dispenser Bottom
	55905C	Bubbler - Flexible (Optional)	57	55996C	Strainer
28	100322740560	Gasket - Bubbler (upper and lower)	58	45485C	Waste Line Assembly
29	66743C	Condenser	59	31376C	Power Cord
30	66703C	Drier	60	70682C	Fitting - Tee 1/4
31	61314C	Regulator	NS	400660943730	Hanger Bracket
32	70864C	Screw #8 x 5/8" Lg. Torx/Slot			

\*REPLACE WITH SAME COMPRESSOR USED IN ORIGINAL ASSEMBLY.

NOTE: All correspondence pertaining to any of the above water coolers or orders for repair parts MUST include Model No. and Serial No. of cooler, name and part number of replacement part.

COLOR TABLE

PANEL COLOR	Item No. 5 Part No.	Item No. 6 Part No.	Item No. 7 Part No.	Item No. 13 Part No.	Item No. 14 Part No.	Item No. 15 Part No.	Item No. 16 Part No.	Item No. 17 Part No.	Item No. 56 Part No.
Platinum Vinyl	22820C	22812C	23135C	22860C	22844C	26806C	22852C	26798C	55931C
Almond Vinyl	23016C	23009C	23162C	22968C	22954C	26772C	22961C	26765C	55931C
Aztec Gold	27899C	27897C	27907C	27911C	27905C	27903C	27909C	27901C	55930C
Stainless Steel	22822C	22814C	23137C	22862C	22955C	26776C	22854C	26800C	55931C

WIRING DIAGRAM

This Drawing is merely for illustrating the components of the electrical system.

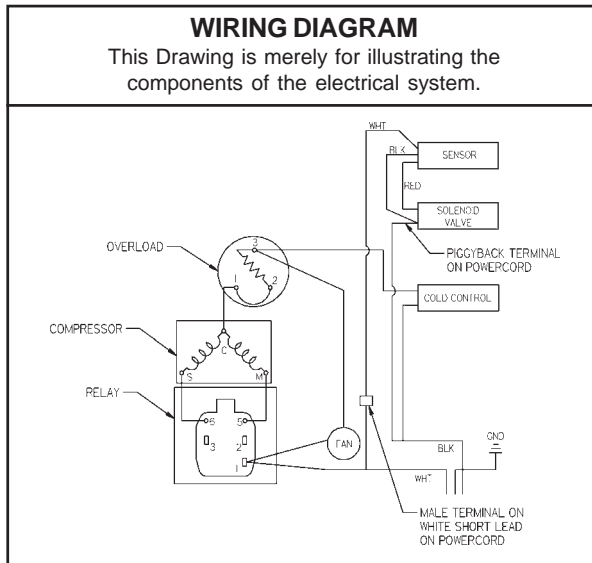

**Halsey Taylor**

2222 CAMDEN COURT  
OAK BROOK, IL 60523  
630.574.3500

PRINTED IN U.S.A.