

HAC8-EE-BL-Q*1D
HALSEY TAYLOR OWNERS MANUAL
 USES HFC-134A REFRIGERANT

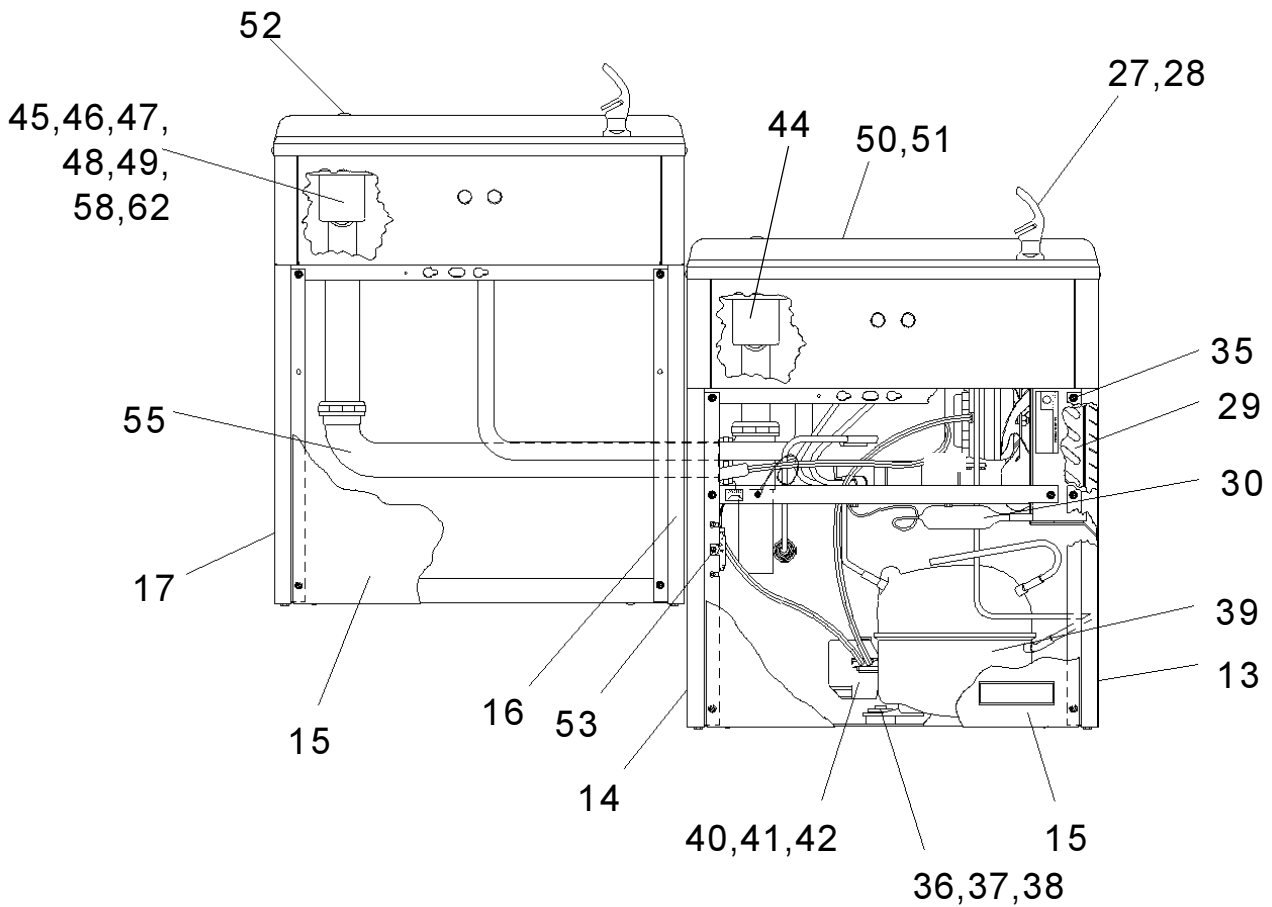

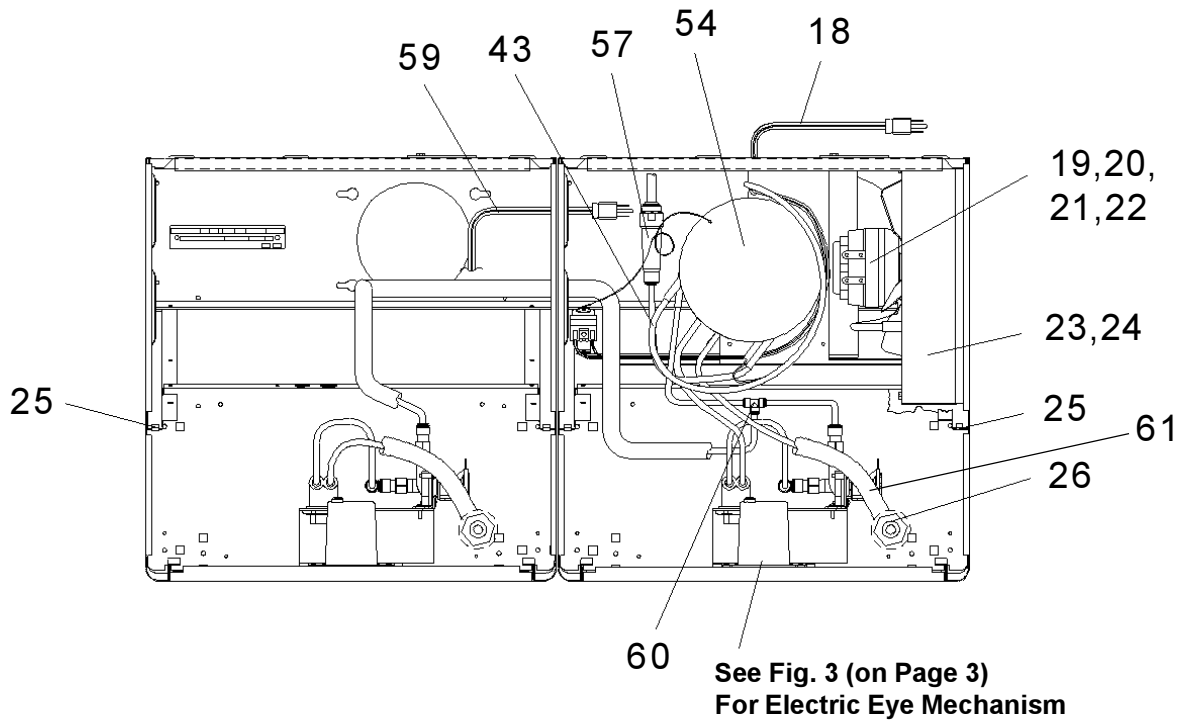
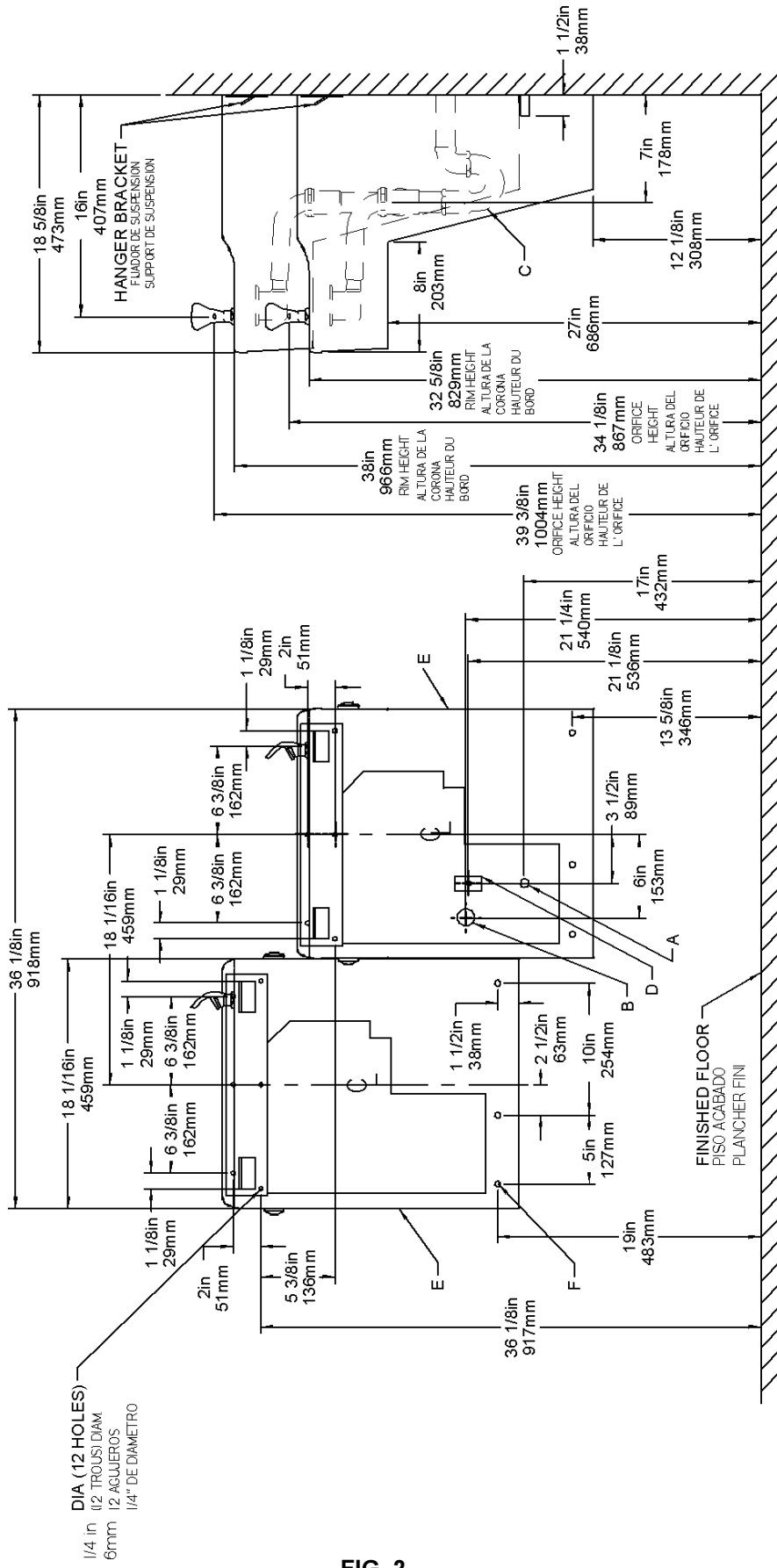

FIG. 2

DIA (12 HOLES)
1/4 in (12 TROUS) DIAM.
6mm
1/4" DE DIAMETRO

LEGENDA/LEGENDE
A = RECOMMENDED WATER SUPPLY LOCATION 3/8 O.D. UNPLATED COPPER TUBE CONNECT STUB 1-1/2 IN. (38 mm) OUT FROM WALL SHUT OFF BY OTHERS
 SE RECOMIENDA UBICAR EL TUBO CORTO DE CONEXIÓN AL TUBO DE COBRE SIN CHAPAR DE 3/8" DE DIAM. EXT A 1-1/2" (38 mm) FUERA DE LA LLAVE DE PASO EN LA PARED COLOCADA POR TERCEROS
 EMPACEMENT RECOMMANDÉ D'ALIMENTATION EN EAU PAR TUBE EN CUIVRE NON PLAQUÉ DE 3/8 PO. (9.5 mm) D.E. CONNECTANT UNE TUYAUTERIE DE 1-1/2 PO. (38 mm) DEPUIS LE ROBINET D'ARRÊT FOURNIR PAR D'AUTRES

B = RECOMMENDED LOCATION FOR WASTE OUTLET 1-1/4" O.D. DRAIN
 UBICACIÓN RECOMENDADA PARA EL DRENAJE DE SALIDA DE AGUA, DE 1 1/4" DE DIÁMETRO.
 EMPACEMENT RECOMMANDÉ POUR LE DRAIN DE D.E. 1-1/4" DE SORTIE D'EAU.

C = 1-1/4 TRAP NOT FURNISHED**
 PURGADOR DE 1 1/4 NO PROPORCIONADO**
SIPHON 1-1/4 NON FOURNI**

D = ELECTRICAL SUPPLY (3) WIRE RECESSED BOX
 CAJA RECESIVA DE ALAMBRES (3) DE SUMINISTRO ELÉCTRICO
 BOÎTE ENCASTRÉE D'ALIMENTATION ÉLECTRIQUE (3) FILS

E = INSURE PROPER VENTILATION BY MAINTAINING 6" (152 mm) (MIN.) CLEARANCE FROM CABINET LOUVERS TO WALL.
 ASEGURE UNA VENTILACIÓN ADECUADA MANTENIENDO UN ESPACIO E 6" (152 mm) (MÍN.) DE HOLSURA ENTRE LA REJILLA DE VENTILACIÓN DEL MUEBLE Y LA PARED
 ASSUREZ VOUS UNE BONNE VENTILATION EN GARDANT 6" (152 mm) (MIN.) ENTRE LES ÉVÉNENTS DE L'ENCAINTE ET LE MUR.

F = 7/16 BOLT HOLES FOR FASTENING UNIT TO WALL
 AGUJEROS DE LAS TUERCAS DE 7/16 PARA SUJETAR LA UNIDAD A LA PARED
 TROUS D'ÉCROUS 7/16 POUR FIXER L'APPAREIL AU MUR

*ADA REQUIREMENT
 *REQUISITO DE A.D.A.
 *EXIGENCE ADA

**When replacing a Model "BFC" with a new unit Model "HAC", installer must cut 1-1/2 inches from length of cooler waste line before connecting to trap (see installation instruction No.7)
 **Cuando reemplaza un Modelo "BFC" con una unidad nueva Modelo "HAC" el instalador deberá cortar 1 1/2 pulgadas del largo del tubo de desague del enfriador antes de conectar el purgador (vea las instrucciones de instalación No. 7)
 **En remplaçant un modèle "BFC" avec un nouveau modèle "HAC", l'installateur doit couper 1 1/2 pouce de longueur de la canalisation résiduaire du refroidisseur avant de le raccorder au siphon (voir instruction d'installation no. 7)

PUSH BAR MECHANISM

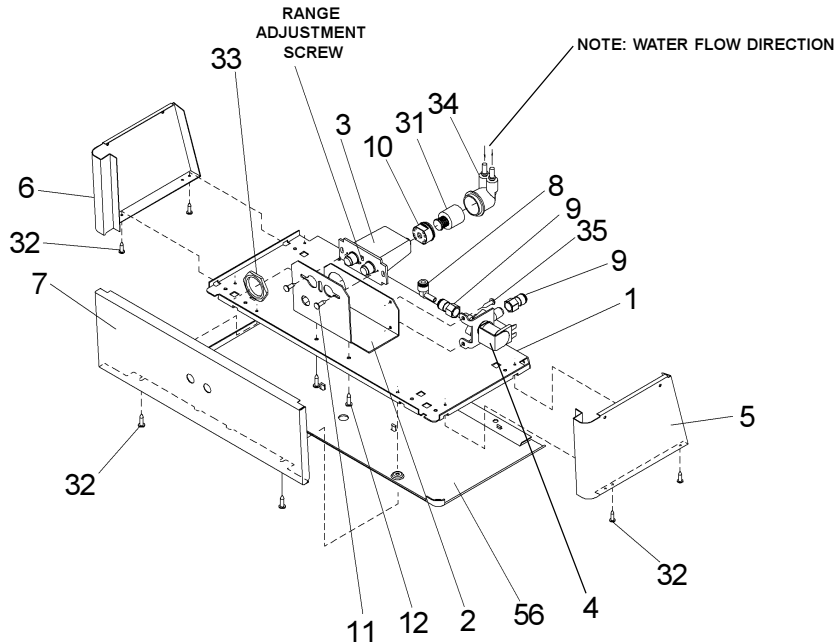

FIG. 3

Sensor Control: If sensor fails to operate valve mechanism or operates erratically, check the following.

- Ensure there are no obstructions within a 40-inch radius from front of cooler.
- Check wire connections at solenoid valve and sensor.

CAUTION: Make sure unit is unplugged before checking any wiring.

- Ensure proper operation of solenoid valve. If there is an audible clicking sound yet no water flows, look for an obstruction in the valve itself or elsewhere in the water supply line.

Sensor Range Adjustment: The electronic sensor used in this cooler is factory pre-set for a "visual" range of 36 inches. If actual range varies greatly from this, or a different setting is desired, follow the range adjustment procedure below:

- Remove front panel of cooler.
- Using a small tip screwdriver, rotate range adjustment screw clockwise to increase range and counter-clockwise to decrease range. (See Fig. 3).

CAUTION: Complete range of sensor (24-48 inches) is only one turn of the adjusting screw.

- Replace the front panel.

**IMPORTANT
ALL SERVICE TO BE PERFORMED BY AN
AUTHORIZED SERVICE PERSON**

CAUTION: Cleaning of Aztec Gold Models requires special care. Outer surfaces must be cleaned with a mild detergent or mixture of vinegar and water only, rinsed and wiped dry. Abrasive and acidic cleaners may eventually damage the Aztec Gold finish.

**HANGER BRACKETS & TRAP
INSTALLATION**

- Remove hanger bracket fastened to back of cooler by removing one (1) screw.
 - Mount the hanger bracket and trap as shown in Figure 2.
- NOTE:** Hanger Bracket **MUST** be supported securely. Add fixture support carrier if wall will not provide adequate support.

IMPORTANT:

- 7 in. (178mm) dimension from wall to centerline of trap must be maintained for proper fit.
 - Anchor hanger securely to wall using all six (6) 1/4 in. dia. mounting holes.
- Install straight valve for 3/8" O.D. tube.

INSTALLATION OF COOLER

- Hang the cooler on the hanger bracket. Be certain the hanger bracket is engaged properly in the slots on the cooler back as shown in Fig. 4.
- Loosen the two (2) screws holding the lower front panel at the bottom of cooler base and two (2) screws at the top. Remove the front panel and set aside.
- Connect water inlet line--See Note 4 of General Instructions.
- Remove the slip nut and gasket from the trap and install them on the cooler waste line making sure that the end of the waste line fits into the trap. Assemble the slip nut and gasket to the trap and tighten securely. Plug both power cords into duplex receptacle.

START UP

Also See General Instructions

- Stream height is factory set at 45-50 PSI. If supply pressure varies greatly from this, readjust stream height to approximately 1-1/2" (38mm) above the bubbler guard by turning adjustment screw, accessible by removing front panel, Item No.7 (see Fig.3 & 5).
- Replace the front panel and secure by retightening four (4) screws.
- If a taste, odor or sediment problem is prevalent, try installing our water filter module, part no 73-15242-51-550

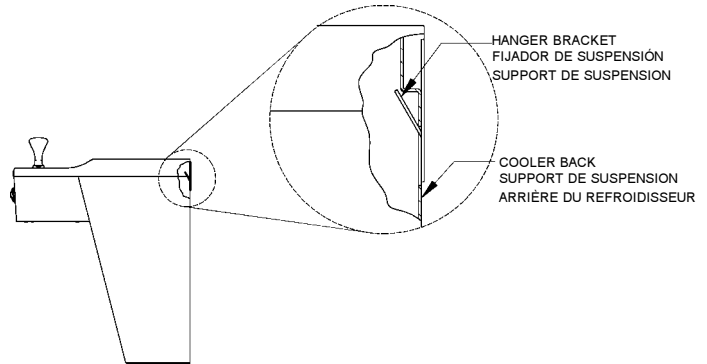
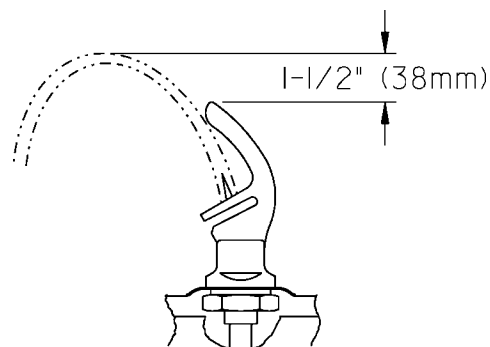

FIG. 4



CORRECT STREAM HEIGHT

FIG. 5

ITEMIZED PARTS LIST

ITEM NO	PART NO	DESCRIPTION
1	22897C	Panel - Bottom Dispenser
2	26729C	Bracket - Valve Mounting
3	31516C	Sensor - Clear (115V)
4	31272C	Solenoid Valve (115V)
5	See Color Table	Panel - Right Side
6	See Color Table	Panel - Left Side
7	See Color Table	Panel - Front
8	70817C	Elbow 1/4 Stem x 1/4 O.D.
9	75507C	Fitting 1/4 NPTF x 1/4 O.D.
10	56082C	Nut - Regulator
11	70644C	Screw #6-32 x 1/2" Lg. PHMS
12	75497C	Screw #10 x 1/2" Lg. PHSM
13	See Color Table	Panel - Right Rear (Refrig. Unit)
14	See Color Table	Panel - Left Rear (Refrig. Unit)
15	See Color Table	Panel - Front Lower
16	See Color Table	Panel - Right Rear (Left Unit)
17	See Color Table	Panel - Left Rear (Left Unit)
18	31483C	Power Cord
19	30699C	Fan Blade
20	70018C	Hex Nut - Fan Blade
21	31490C	Fan Motor
22	70009C	Screw - (Fan Motor)
23	22899C	Shroud - Fan
24	38417001	Screw - #8-18 x 3/8" Lg. (Fan Shroud)
25	75524C	Clip (Front and Rear Panels)
26	15012C	Nipple - Bubbler
27	51544C	Bubbler - Chrome
	45396C	Bubbler - Aztec Gold
	55905C	Bubbler - Flexible (Optional)
28	100322740560	Gasket - Bubbler (upper and lower)
29	62152C	Condenser
30	66202C	Drier
31	61314C	Regulator
32	70864C	Screw #8 x 5/8" Lg. Torx/Slot
33	40045C	Hex Nut
34	50986C	Holder - Regulator
35	70002C	Screw #10 x 1/2" Lg. HHSM
36	101516143550	Stud - Compressor Mtg.
37	100806740570	Grommet - Compressor Mtg.
38	19037000	Clip - Compressor Mtg.

ITEMIZED PARTS LIST

ITEM NO	PART NO	DESCRIPTION
39*	35960C	Compressor Serv. Pak EM65
40	35959C	Relay
41	35768C	Cover - Relay
42	35958C	Overload
43	66532C	Heat Exchanger
44	45351C	Waste Line Assembly
45	55884C	Fitting - Elbow 1-1/4
46	75588C	Nut - Slip Joint 1-1/4
47	100147140560	Gasket - Drain
48	102639931640	Drain Plug - Chrome
	45413C	Drain Plug - Aztec Gold
49	160270508640	Strainer Plate - Chrome
	45400C	Strainer Plate - Aztec Gold
50	22893C	Basin - Stainless Steel
	27594C	Basin - Aztec Gold
51	75532C	Screw - Basin Mtg. - Stainless Steel
	75573C	Screw - Basin Mtg. - Aztec Gold
52	100687608640	Plug Button - Chrome
	75571C	Plug Button - Aztec Gold
53	31513C	Cold Control
54	66534C	Evaporator Assembly
55	40022C	Waste Line Assembly
56	See Color Table	Cover - Dispenser Bottom
57	55996C	Strainer
58	45485C	Waste Line Assembly
59	31376C	Power Cord
60	70682C	Fitting - Tee 1/4
61	56092C	Tubing - Poly 48" (Cut To Length)
62	75589C	Gasket
NS	400660943730	Hanger Bracket

*REPLACE WITH SAME COMPRESSOR USED IN ORIGINAL ASSEMBLY.

NOTE: All correspondence pertaining to any of the above water coolers or orders for repair parts MUST include Model No. and Serial No. of cooler, name and part number of replacement part.

COLOR TABLE

PANEL COLOR	Item No. 5 Part No.	Item No. 6 Part No.	Item No. 7 Part No.	Item No. 13 Part No.	Item No. 14 Part No.	Item No. 15 Part No.	Item No. 16 Part No.	Item No. 17 Part No.	Item No. 56 Part No.
Platinum Vinyl	22820C	22812C	23135C	22860C	26798C	22844C	26806C	22852C	55931C
Almond Vinyl	23016C	23009C	23162C	22968C	26765C	22954C	26772C	22961C	55931C
Aztec Gold	27899C	27897C	27907C	27911C	27901C	27905C	27903C	27909C	55930C
Stainless Steel	22822C	22814C	23137C	22862C	26800C	22955C	26776C	22854C	55931C

WIRING DIAGRAM

This Drawing is merely for illustrating the components of the electrical system.

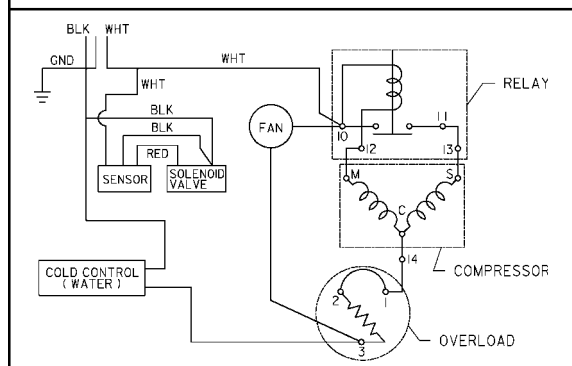

Halsey Taylor

2222 CAMDEN COURT
OAK BROOK, IL 60523
630.574.3500

PRINTED IN U.S.A.