

**HALSEY TAYLOR OWNERS MANUAL**

USES HFC-134A REFRIGERANT

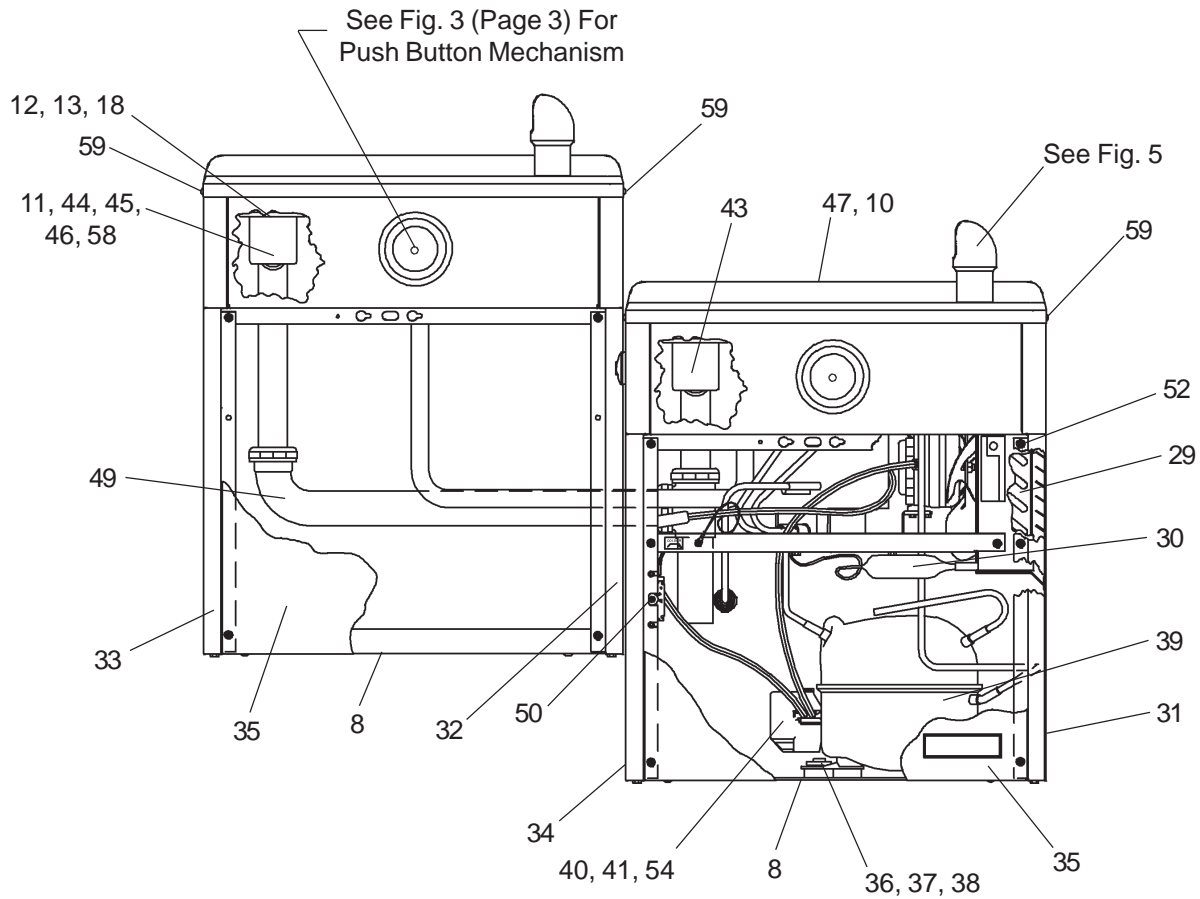

**FIG. 1**

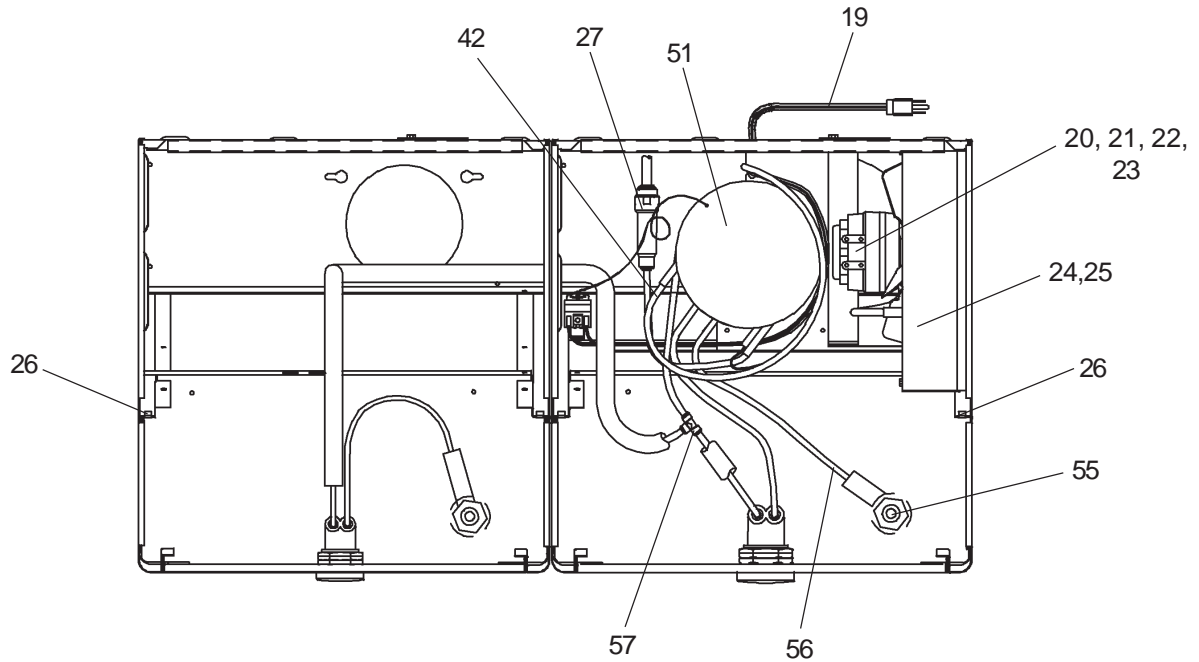
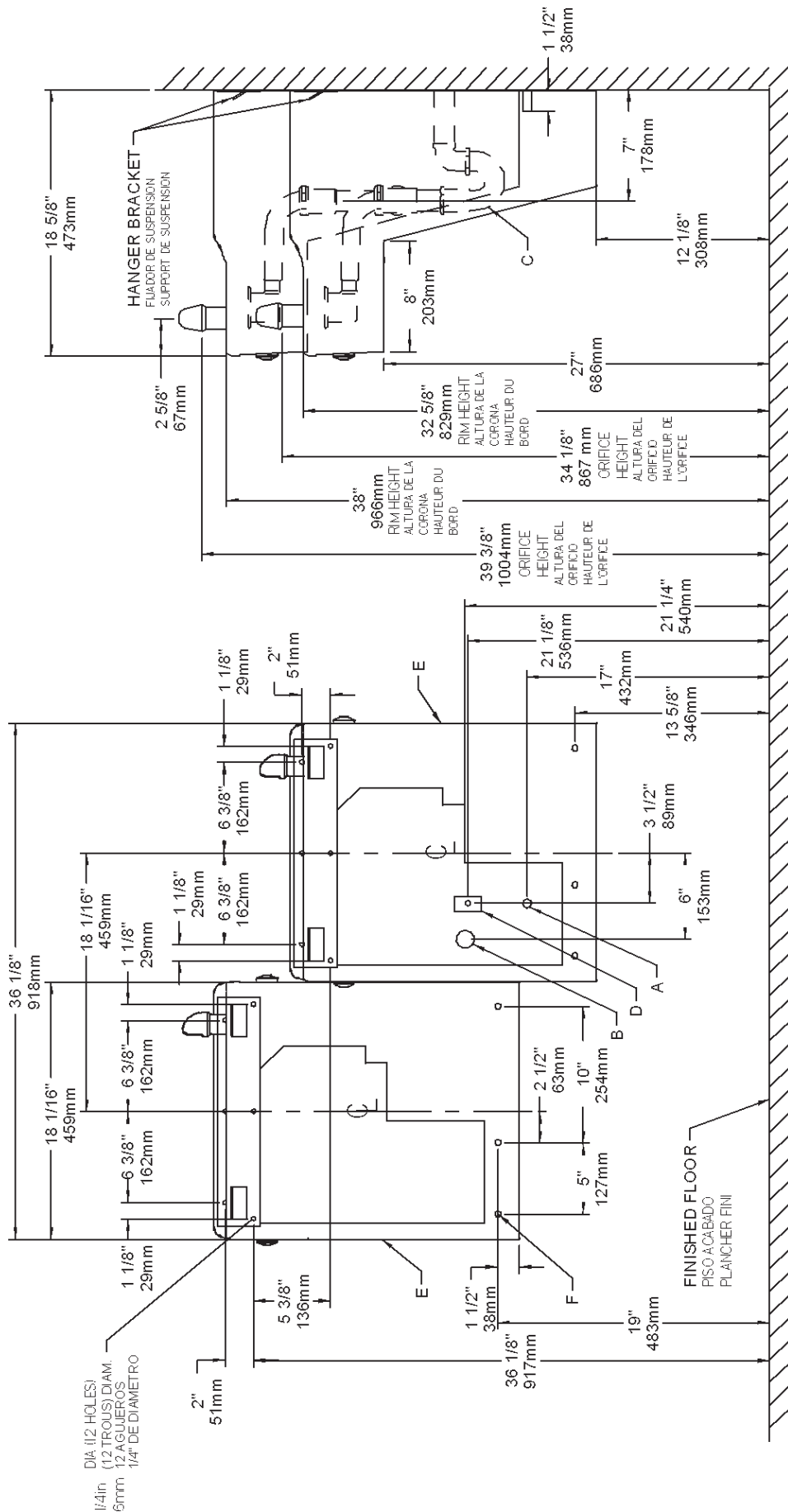

FIG. 2

**LEGEND/LEYENDA/LÉGENDE**

**A = RECOMMENDED WATER SUPPLY LOCATION 3/8 O.D. UNPLATED COPPER TUBE CONNECT STUB 1-1/2 IN. (38 mm) OUT FROM WALL SHUT OFF BY OTHERS**

SE RECOMIENDA UBICAR EL TUBO CORTO DE CONEXIÓN AL TUBO DE COBRE SINI CHAPAR DE 3/8" DE DIÁM. EXT. A 1-1/2" (38 mm) FUERA DE LA LLAVE DE PASO EN LA PARED COLOCADA POR TERCEROS.

**B = RECOMMENDED LOCATION FOR WASTE OUTLET 1-1/2" O.D. DRAIN**

EMPLACEMENT RECOMMANDÉ D'ALIMENTATION EN EAU PAR TUBE EN CUIVRE NON PLAQUÉ DE 3/8 PO. (9,5 mm) DE. CONNECTANT UNE TUYAUTERIE DE 1-1/2 PO. (38 mm) DEPUIS LE ROBINET D'ARRÊT FOURNI PAR D'AUTRES.

**C = 1-1/2 TRAP NOT FURNISHED\*\***

EMPLACEMENT RECOMMANDÉ POUR LE DRAIN DE D.E. 1-1/2" DE SORTIE D'EAU.

**D = ELECTRICAL SUPPLY (3) WIRE RECESSED BOX**

PURGADOR DE 1-1/2 NO PROPORCIONADO\*\*

**E = INSURE PROPER VENTILATION BY MAINTAINING 6" (152 mm) (MIN.) CLEARANCE FROM CABINET LOUVERS TO WALL.**

CAJA RECESIVA DE ALAMBRES (3) DE SUMINISTRO ELÉCTRICO

BOÎTE ENCASTRÉE D'ALIMENTATION ÉLECTRIQUE (3) FILS

**F = 7/16 BOLT HOLES FOR FASTENING UNIT TO WALL**

AGUJEROS DE LAS TUERCAS DE 7/16 PARA SUJETAR LA UNIDAD A LA PARED

TROUS D'ÉCROUS 7/16 POUR FIXER L'APPAREIL AU MUR

\*ADA REQUIREMENT

\*REQUISITO DE A.D.A.

\*EXIGENCE ADA

\*\*When replacing a Model "BFC" with a new unit Model "HAC", installer must cut 1-1/2 inches from length of cooler waste line before connecting to trap (see installation instruction No.7)

\*\*Cuando reemplaza un Modelo "BFC" con una unidad nueva Modelo "HAC" el instalador deberá cortar 1 1/2 pulgadas de largo del tubo de desague del enfriador antes de conectar al purgador (vea las instrucciones de instalación No. 7)

\*\*En remplaçant un modèle "BFC" avec un nouveau modèle "HAC", l'installateur doit couper 1 1/2 pouce de longueur de la canalisation résiduaire du refroidisseur avant de le raccorder au siphon (voir instruction d'installation no. 7)

## PUSH BAR MECHANISM

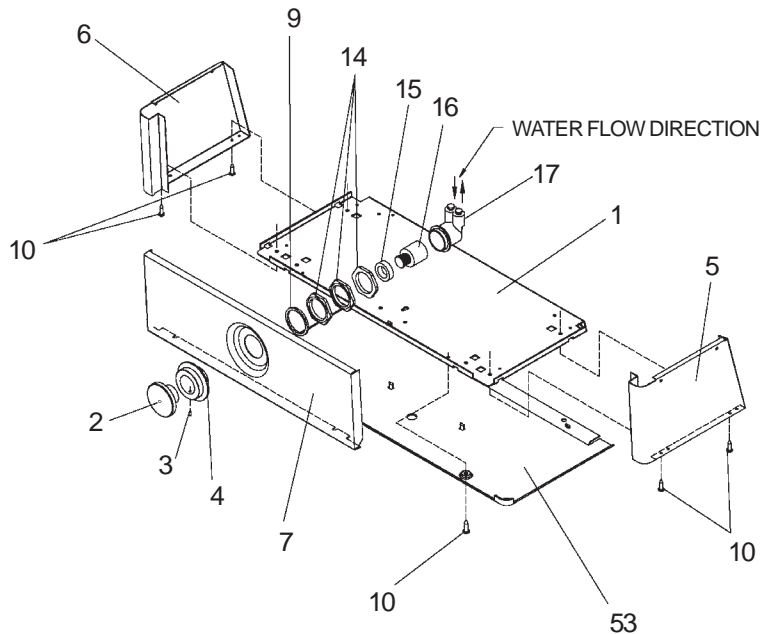

FIG. 3

**IMPORTANT**  
**ALL SERVICE TO BE PERFORMED BY AN**  
**AUTHORIZED SERVICE PERSON**

**CAUTION:** Cleaning of Bronzetone Models requires special care. Outer surfaces must be cleaned with a mild detergent or mixture of vinegar and water only, rinsed and wiped dry. Abrasive and Acidic cleaners may eventually damage the Bronzetone finish.

**HANGER BRACKETS & TRAP**  
**INSTALLATION**

- 1) Remove hanger bracket fastened to back of cooler by removing one (1) screw.
  - 2) Mount the hanger bracket and trap as shown in Figure 2.
- NOTE:** Hanger Bracket MUST be supported securely. Add fixture support carrier if wall will not provide adequate support.

**IMPORTANT:**

- 7 in. (178mm) dimension from wall to centerline of trap must be maintained for proper fit.
  - Anchor hanger securely to wall using all six (6) 1/4 in. dia. mounting holes.
- 3) Install straight valve for 3/8" O.D. tube.

**INSTALLATION OF COOLER**

- 4) Hang the cooler on the hanger bracket. Be certain the hanger bracket is engaged properly in the slots on the cooler back as shown in Fig. 4.
- 5) Loosen the two (2) screws holding the lower front panel at the bottom of cooler base and two (2) screws at the top. Remove the front panel and set aside.
- 6) Connect water inlet line--See Note 4 of General Instructions.
- 7) Remove the slip nut and gasket from the trap and install them on the cooler waste line making sure that the end of the waste line fits into the trap. Assemble the slip nut and gasket to the trap and tighten securely.

**STARTUP**

**Also See General Instructions**

- 8) Stream height is factory set at 45-50 PSI. If supply pressure varies greatly from this, adjust the screw on regulator item 16 by using a small screwdriver through the small hole in the push button item 2 (See Fig.3). CW adjustment will raise stream and CCW adjustment will lower stream. For best adjustment, stream should hit basin approximately 6-1/2" (165mm) from bubbler.

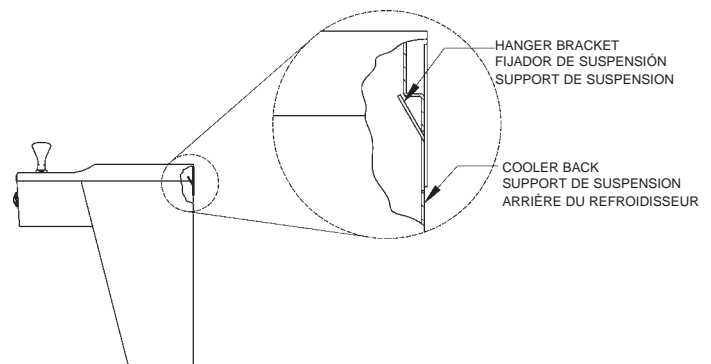

FIG. 4

ITEMIZED PARTS LIST

ITEM NO	PART NO	DESCRIPTION
1	22897C	Panel - Bottom Dispenser
2	45662C	Button - Push
3	75672C	Screw - Cap
4	45663C	Sleeve - Push Button
5	See Color Tbl	Panel - Right Side
6	See Color Tbl	Panel - Left Side
7	See Color Tbl	Panel - Front Push
8	26999C	Cover - Bottom
9	56033C	Washer
10	75570C	Screw - Torx
11	75589C	Gasket
12	160270508640	Strainer - Bright
13	600985451640	Plug - Drain 1-1/2CP
14	40045C	Hex Nut
15	15005C	Retaining - Nut
16	61313C	Regulator
17	50986C	Holder - Regulator
18	110868642550	Screw
19	31517C	Power Cord
20	30664C	Fan Blade
21	70018C	Hex Nut - Fan Blade
22	31490C	Fan Motor
23	70009C	Screw - (Fan Motor)
24	22899C	Shroud - Fan
25	38417001	Screw - #8-18 x 3/8" Lg. (Fan Shroud)
26	75524C	Clip (Front and Rear Panels)
27	55996C	Strainer (See "General Instructions")
28	98118C	Bubbler Assembly
29	62152C	Condenser
30	66703C	Drier
31	See Color Tbl	Panel - Right Rear (Refrig. Unit)
32	See Color Tbl	Panel - Right Rear (Left Unit)
33	See Color Tbl	Panel - Left Rear (Left Unit)
34	See Color Tbl	Panel - Left Rear (Refrig. Unit)
35	See Color Tbl	Panel - Front Lower
36	101516143550	Stud - Compressor Mtg.
37	100806740570	Grommet - Compressor Mtg.
38	19037000	Clip - Compressor Mtg.
*39	36094C	Compressor Serv. Pak EMI 70 HNR
40	35959C	Relay
41	35768C	Cover - Relay
42	66532C	Heat Exchanger
43	45351C	Wasteline Assy.
44	100147140560	Gasket - Drain
45	56121C	Fitting - Elbow
46	75588C	Nut - Slip Joint 1-1/4
47	28462C	Basin - Stainless Steel
48	100322740560	Washer
49	40022C	Wasteline Assy.
50	31513C	Cold Control
51	66534C	Evaporator Assembly
52	70002C	Screw - #10 x 1/2" Lg. HHSM
53	55931C	Cover-Dispenser Bottom Gray
54	36158C	Overload
55	15009C	Bubbler - Nipple
56	56092C	Tubing - Poly (Cut To Length)
57	70682C	Fitting - Tee 1/4
58	45485C	Tailpiece Assembly
59	75661C	Screw - Torx
NS	400660943730	Hanger Bracket (Not Shown)
NS	75583C	Fitting - Elbow 5/16" - 1/4" (Not Shown)
NS	75523C	Bit - Pinned Torx
NS	75520C	Bit - Pinned Torx
NS	75674C	Wrench - Allen 7/64

COLOR TABLE		
Item No.	Part No.	Panel Color
5	22822C	Stainless Steel
6	22814C	Stainless Steel
7	27295C	Stainless Steel
31	22862C	Stainless Steel
32	26776C	Stainless Steel
33	22854C	Stainless Steel
34	26800C	Stainless Steel
35	22955C	Stainless Steel

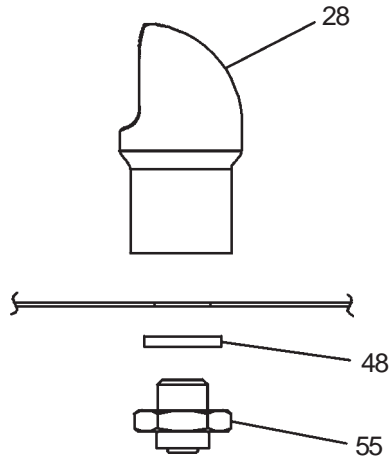

FIG. 5

**\*REPLACE WITH SAME COMPRESSOR USED IN ORIGINAL ASSEMBLY.**

**NOTE:** All correspondence pertaining to any of the above water coolers or orders for repair parts **MUST** include Model No. and Serial No. of cooler, name and part number of replacement part.