

**HALSEY TAYLOR OWNERS MANUAL**

USES HFC-134A REFRIGERANT

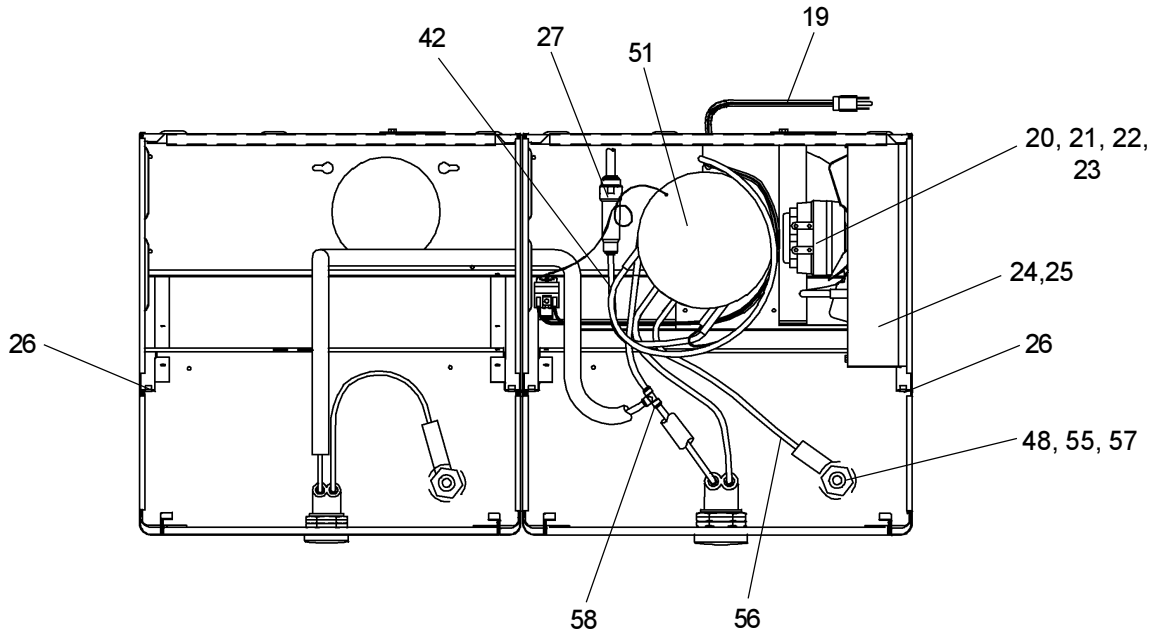

See Fig. 3 (Page 3) For Push Button Mechanism

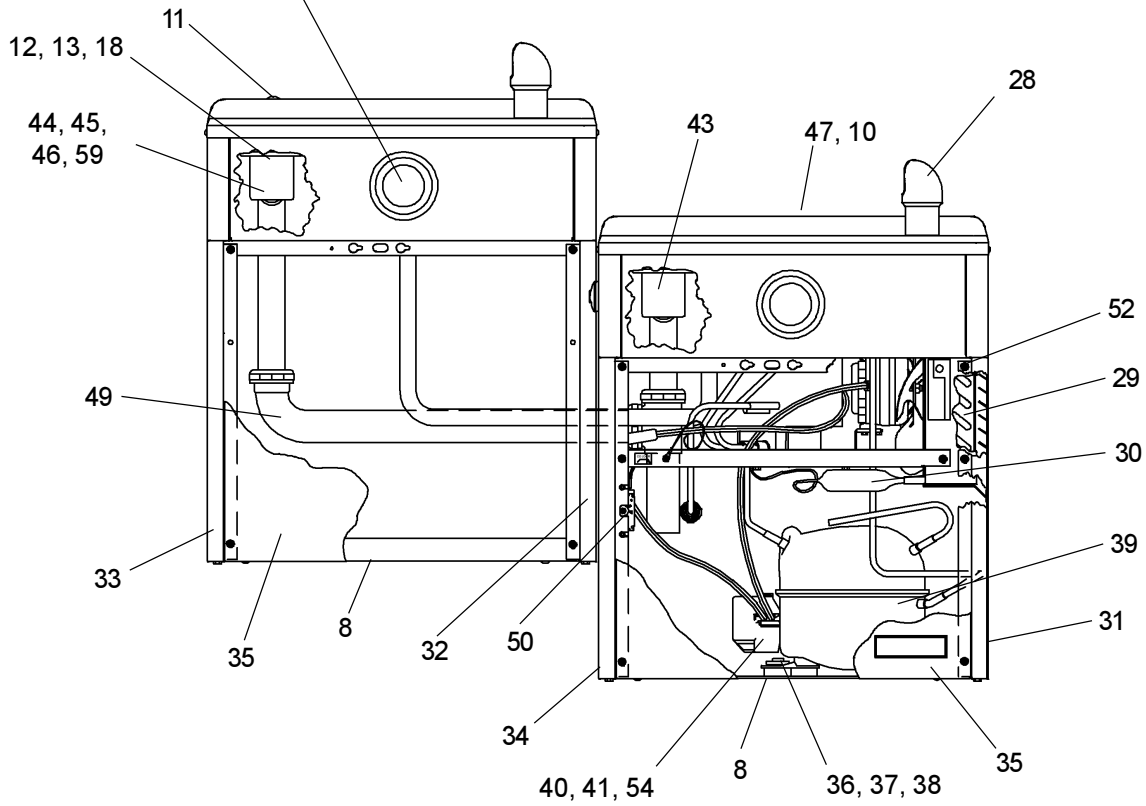

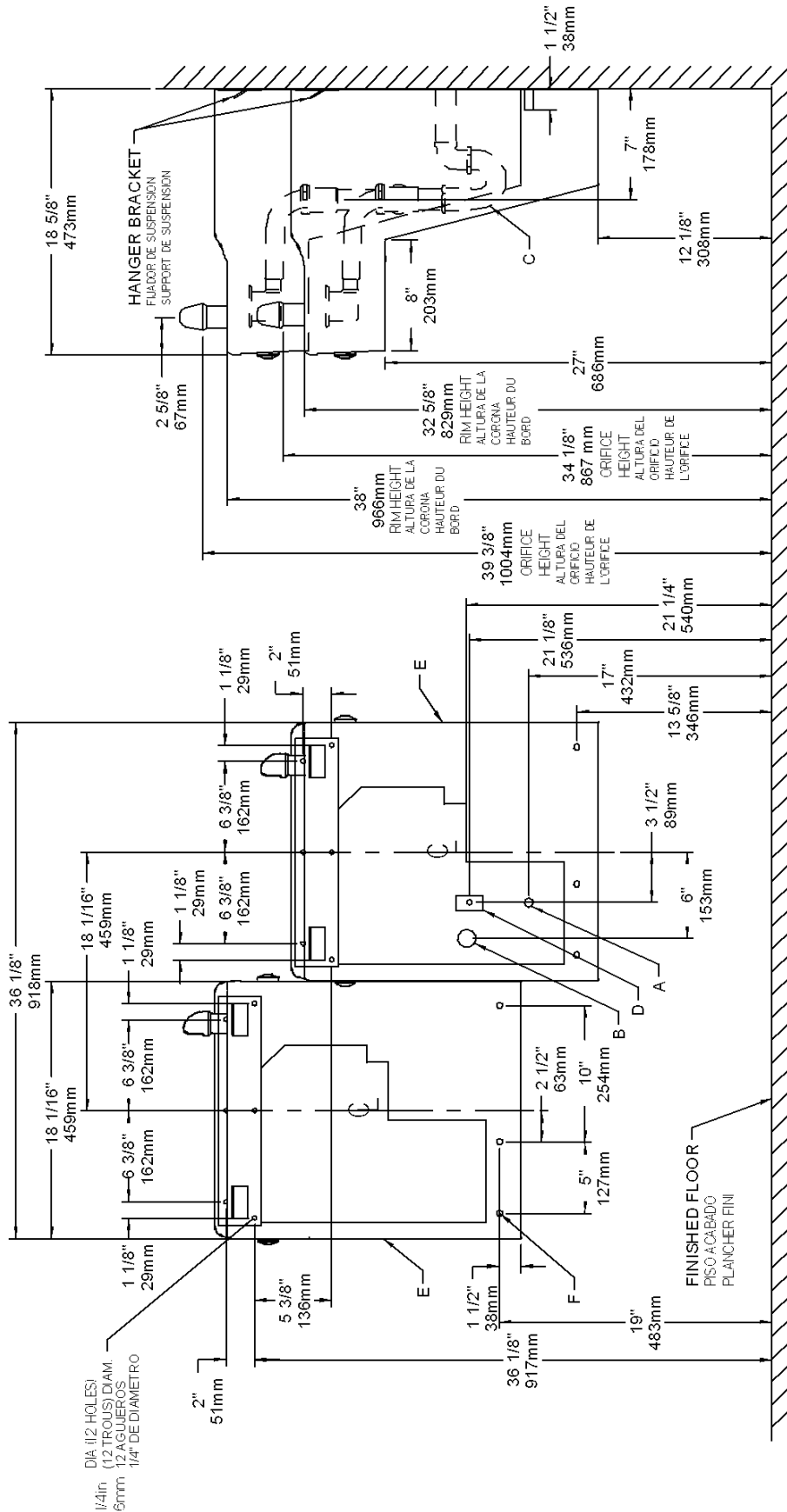

FIG. 2

- LEGEND/LEYENDA/LÉGENDE**
- A = RECOMMENDED WATER SUPPLY LOCATION 3/8 O.D. UNPLATED COPPER TUBE CONNECT STUB 1-1/2 IN. (38 mm) OUT FROM WALL SHUT OFF BY OTHERS**  
SE RECOMIENDA UBICAR EL TUBO CORTO DE CONEXIÓN AL TUBO DE COBRE SIN CHAPAR DE 3/8" DE DIAM. EXT. A 1-1/2" (38 mm) FUERA DE LA LAVE DE PASE EN LA PARED COLOCADA POR TERCEROS.
  - B = RECOMMENDED LOCATION FOR WASTE OUTLET 1-1/4" O.D. DRAIN**  
UBICACIÓN RECOMENDADA PARA EL DRENAJE DE SALIDA DE AGUA, DE 1 1/4" DE DIÁMETRO.
  - C = 1-1/4 TRAP NOT FURNISHED\*\***  
PURGADOR DE 1 1/4 NO PROPORCIONADO\*\*
  - D = ELECTRICAL SUPPLY (3) WIRE RECESSED BOX**  
CAJA RECESIVADA DE ALAMBRES (3) DE SUMINISTRO ELÉCTRICO
  - E = INSURE PROPER VENTILATION BY MAINTAINING 6" (152 mm) (MIN.) CLEARANCE FROM CABINET LOUVERS TO WALL.**  
ASEGURE UNA VENTILACIÓN ADECUADA MANTENIENDO UN ESPACIO E 6" (152 mm) (MÍN.) DE HOLGURA ENTRE LA REJILLA DE VENTILACIÓN DEL MUEBLE Y LA PARED
  - F = 7/16 BOLT HOLES FOR FASTENING UNIT TO WALL**  
TROS D'ECROUS 7/16 POUR FIXER L'APPAREIL AU MUR

\*ADA REQUIREMENT  
\*REQUISITO DE A.D.A.  
\*EXIGENCE ADA

\*\*When replacing a Model "BFC" with a new unit Model "HAC", installer must cut 1-1/2 inches from length of cooler waste line before connecting to trap (see installation instruction No. 7)

\*\*Cuando reemplaza un Modelo "BFC" con una unidad nueva Modelo "HAC", el instalador deberá cortar 1 1/2 pulgadas del largo del tubo de desague del enfriador antes de conectar al purgador (vea las instrucciones de instalación No. 7)

\*\*En remplaçant un modèle "BFC" avec un nouveau modèle "HAC", l'installateur doit couper 1 1/2 pouce de longueur de la canalisation résiduaire du refroidisseur avant de le raccorder au siphon (voir instruction d'installation no. 7)

**PUSH BAR MECHANISM**

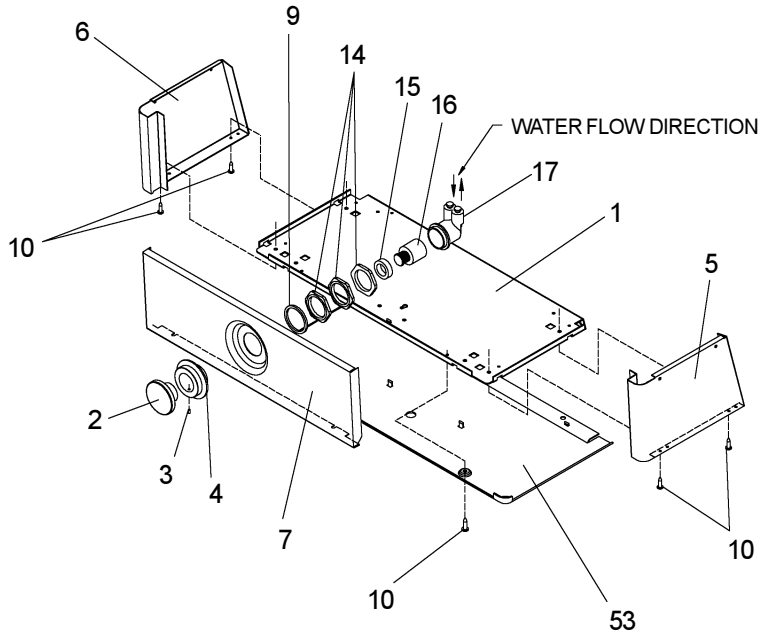

**FIG. 3**

**IMPORTANT  
ALL SERVICE TO BE PERFORMED BY AN  
AUTHORIZED SERVICE PERSON**

**CAUTION:** Cleaning of Bronzetone Models requires special care. Outer surfaces must be cleaned with a mild detergent or mixture of vinegar and water only, rinsed and wiped dry. Abrasive and Acidic cleaners may eventually damage the Bronzetone finish.

**HANGER BRACKETS & TRAP  
INSTALLATION**

- 1) Remove hanger bracket fastened to back of cooler by removing one (1) screw.
  - 2) Mount the hanger bracket and trap as shown in Figure 2.
- NOTE:** Hanger Bracket **MUST** be supported securely. Add fixture support carrier if wall will not provide adequate support.

**IMPORTANT:**

- 7 in. (178mm) dimension from wall to centerline of trap must be maintained for proper fit.
  - Anchor hanger securely to wall using all six (6) 1/4 in. dia. mounting holes.
- 3) Install straight valve for 3/8" O.D. tube.

**INSTALLATION OF COOLER**

- 4) Hang the cooler on the hanger bracket. Be certain the hanger bracket is engaged properly in the slots on the cooler back as shown in Fig. 4.
- 5) Loosen the two (2) screws holding the lower front panel at the bottom of cooler base and two (2) screws at the top. Remove the front panel and set aside.
- 6) Connect water inlet line--See Note 4 of General Instructions.
- 7) Remove the slip nut and gasket from the trap and install them on the cooler waste line making sure that the end of the waste line fits into the trap. Assemble the slip nut and gasket to the trap and tighten securely.

**START UP**

**Also See General Instructions**

- 8) Stream height is factory set at 45-50 PSI. If supply pressure varies greatly from this, adjust screw, accessible by removing Item 2, Fig. 3. CW adjustment will raise stream and CCW adjustment will lower stream. For best adjustment, stream should hit basin approximately 6-1/2" (165mm) from bubbler.

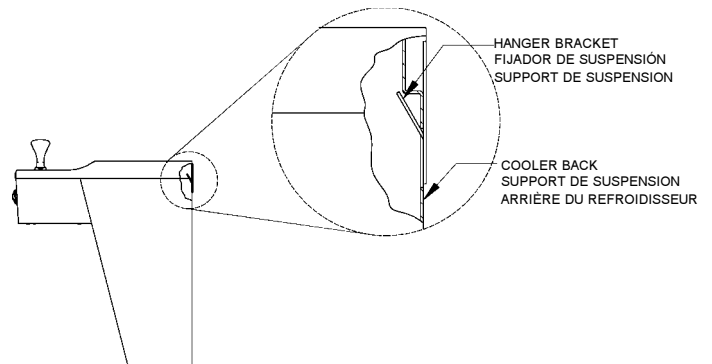

**FIG. 4**

ITEMIZED PARTS LIST

ITEM NO	PART NO	DESCRIPTION
1	22897C	Panel - Bottom Dispenser
2	45662C	Button - Push
3	70022C	Screw - Set
4	45663C	Sleeve - Push Button
5	See Color Tbl	Panel - Right Side
6	See Color Tbl	Panel - Left Side
7	See Color Tbl	Panel - Front Push
8	26999C	Cover - Bottom
9	56033C	Washer
10	75500C	Screw - Torx
11	100687608640	Button - Plug
12	160270508640	Strainer - Bright
13	600985451640	Plug - Drain 1-1/2CP
14	40045C	Hex Nut
15	15005C	Retaining - Nut
16	61313C	Regulator
17	50986C	Holder - Regulator
18	110868642550	Screw
19	31517C	Power Cord
20	30699C	Fan Blade
21	70018C	Hex Nut - Fan Blade
22	31490C	Fan Motor
23	70009C	Screw - (Fan Motor)
24	22899C	Shroud - Fan
25	38417001	Screw - #8-18 x 3/8" Lg. (Fan Shroud)
26	75524C	Clip (Front and Rear Panels)
27	55996C	Strainer (See "General Instructions")
28	45392C	Bubbler
29	62152C	Condenser
30	66202C	Drier
31	See Color Tbl	Panel - Right Rear (Refrig. Unit)
32	See Color Tbl	Panel - Right Rear (Left Unit)
33	See Color Tbl	Panel - Left Rear (Left Unit)
34	See Color Tbl	Panel - Left Rear (Refrig. Unit)
35	See Color Tbl	Panel - Front Lower
36	101516143550	Stud - Compressor Mtg.
37	100806740570	Grommet - Compressor Mtg.
38	19037000	Clip - Compressor Mtg.
*39	35960C	Compressor Serv. Pak EM65
40	35959C	Relay
41	35768C	Cover - Relay
42	66532C	Heat Exchanger
43	45351C	Wasteline Assy.
44	100147140560	Gasket - Drain
45	55884C	Fitting - Elbow
46	75588C	Nut - Slip Joint 1-1/4
47	22893C	Basin - Stainless Steel
48	75564C	Washer-Locking
49	40022C	Wasteline Assy.
50	31513C	Cold Control
51	66534C	Evaporator Assembly
52	70002C	Screw - #10 x 1/2" Lg. HHSM
53	55931C	Cover-Dispenser Bottom Gray
54	35958C	Overload
55	15009C	Bubbler - Nipple
56	56092C	Tubing - Poly 48" (Cut To Length)
NS	400660943730	Hanger Bracket (Not Shown)
57	100322740560	Gasket
58	70682C	Fitting - Tee 1/4
59	45485C	Tailpiece Assembly
60	75589C	Gasket
NS	75583C	Fitting - Elbow 5/16" - 1/4"

COLOR TABLE		
Item No.	Part No.	Panel Color
5	22822C	Stainless Steel
6	22814C	Stainless Steel
7	27295C	Stainless Steel
31	22862C	Stainless Steel
32	26776C	Stainless Steel
33	22854C	Stainless Steel
34	26800C	Stainless Steel
35	22955C	Stainless Steel

**\*REPLACE WITH SAME COMPRESSOR USED IN ORIGINAL ASSEMBLY.**

**NOTE:** All correspondence pertaining to any of the above water coolers or orders for repair parts **MUST** include Model No. and Serial No. of cooler, name and part number of replacement part.

*Halsey Taylor*

2222 CAMDEN COURT  
OAK BROOK, IL 60523  
630.574.3500

PRINTED IN U.S.A.

www.DrinkingFountainDoctor.com

800-518-5388