

# HALSEY TAYLOR OWNERS MANUAL

USES HFC-134A REFRIGERANT

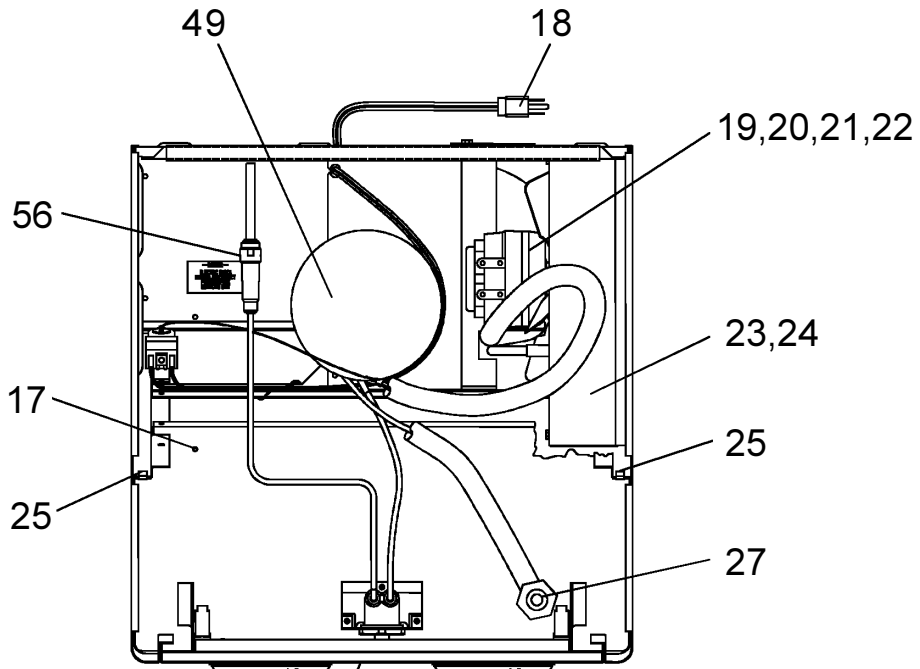

See Fig. 3 (on Page 3)  
For Push Bar Mechanism

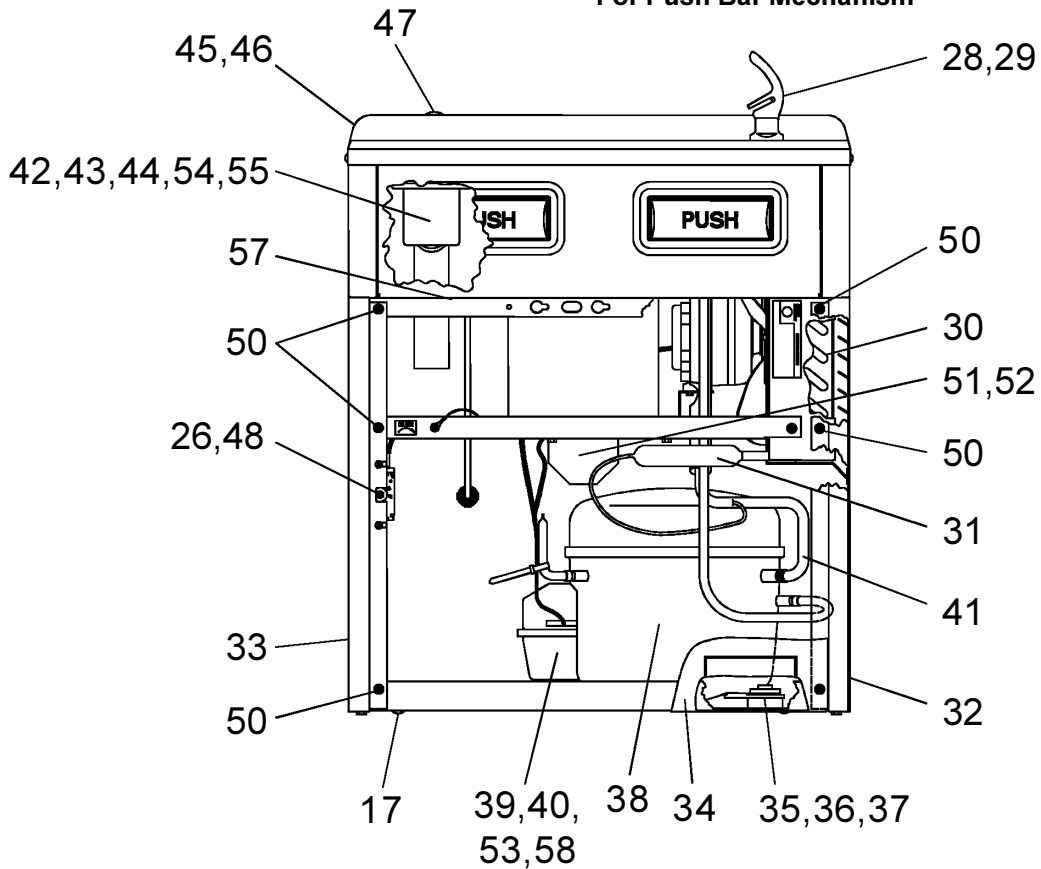

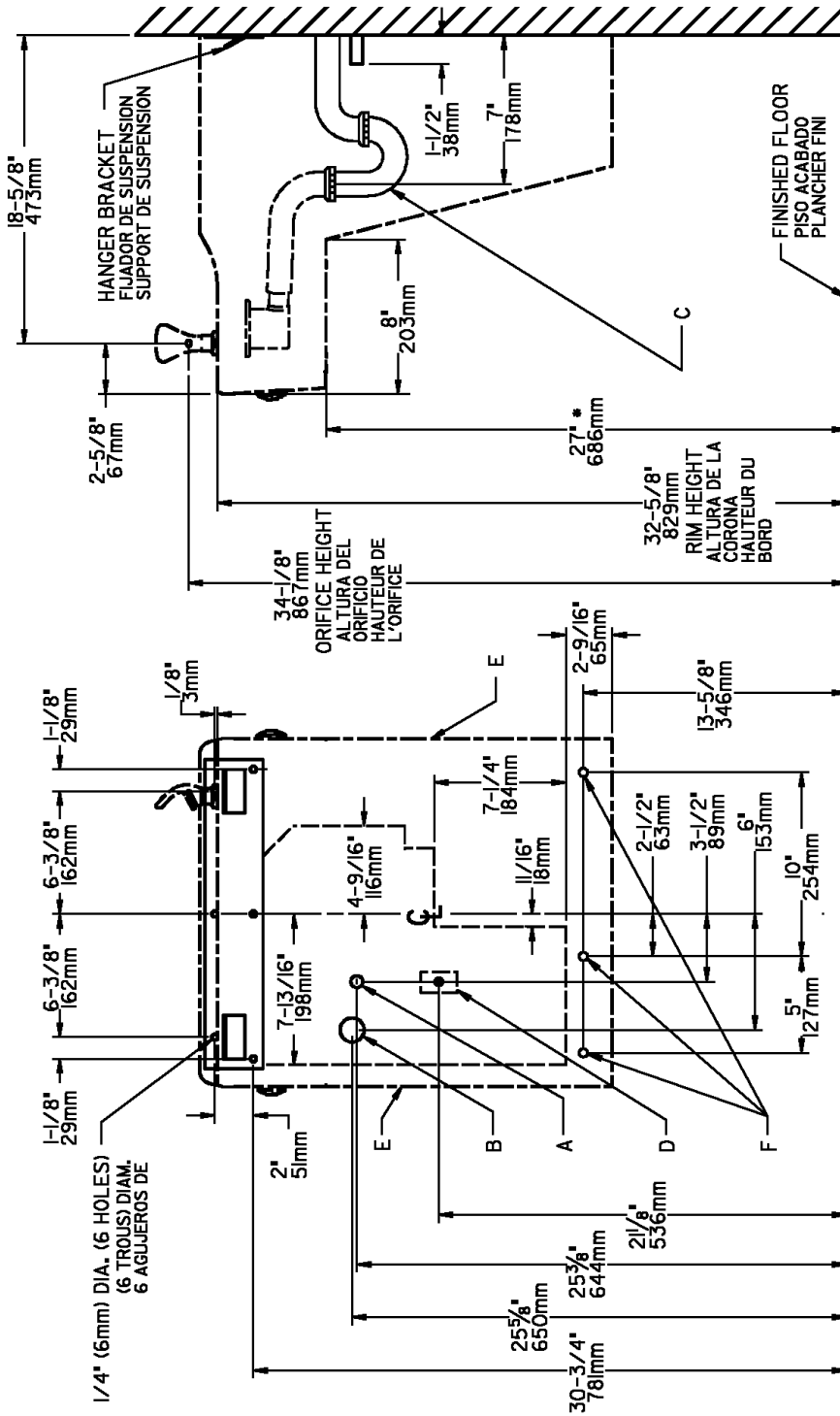

FIG. 2

**LEGEND/LEYENDA/LÉGENDE**  
**A = RECOMMENDED WATER SUPPLY LOCATION 3/8 O.D. UNPLATED COPPER TUBE CONNECT STUB 1-1/2 IN. (38 mm) OUT FROM WALL SHUT OFF BY OTHERS**  
 SE RECOMIENDA UBICAR EL TUBO CORTO DE CONEXIÓN AL TUBO DE COBRE SIN CHAPAR DE 3/8" DE DIÁM. EXT. A 1-1/2" (38 mm) FUERA DE LA LLAVE DE PASO EN LA PARED COLOCADO POR TERCEROS.  
**B = RECOMMENDED LOCATION FOR WASTE OUTLET 1-1/4" O.D. DRAIN**  
 UBICACION RECOMENDADA PARA EL DRENAJE DE SALIDA DE AGUA DE 1-1/4" DE DIÁMETRO.  
**C = 1-1/4" TRAP NOT FURNISHED\***  
 PURGADOR DE 1-1/4" NO PROPORCIONADO\*\*  
**D = ELECTRICAL SUPPLY (3) WIRE RECESSED BOX WITH GROUND FAULT CIRCUIT INTERRUPTER (GFCI)**  
 CAJA RECESIVADA DE ALAMBRES (3) DE SUMINISTRO ELÉCTRICO  
**E = INSURE PROPER VENTILATION BY MAINTAINING 6" (152 mm) (MIN.) CLEARANCE FROM CABINET LOUVERS TO WALL.**  
 ASEGURE UNA VENTILACIÓN ADECUADA MANTENIENDO UN ESPACIO E 6" (152 mm) (MÍN.) DE HOLGURA ENTRE LA REJILLA DE VENTILACIÓN DEL MUEBLE Y LA PARED  
**F = 7/16 BOLT HOLES FOR FASTENING UNIT TO WALL**  
 TROUS D'ÉCROUS 7/16 POUR FIXER L'APPAREIL AU MUR

\*ADA REQUIREMENT  
 \*REQUISITO DE A.D.A.  
 \*EXIGENCE ADA

\*\*When replacing a Model "BFC" with a new unit Model "HAC", install must cut 1-1/2 inches from length of cooler waste line before connecting to trap (see installation instruction No.7)  
 \*\*Cuando reemplace un Modelo "BFC" con una unidad nueva Modelo "HAC" el instalador deberá cortar 1 1/2 pulgadas del largo del tubo de desagüe del enfriador antes de conectar el purgador (vea las instrucciones de instalación No. 7)  
 \*\*En remplaçant un modèle "BFC" avec un nouveau modèle "HAC", l'installateur doit couper 1 1/2 pouce de longueur de la canalisation résiduaire du refroidisseur avant de le raccorder au siphon (voir instruction d'installation no. 7)

**PUSH BAR MECHANISM**

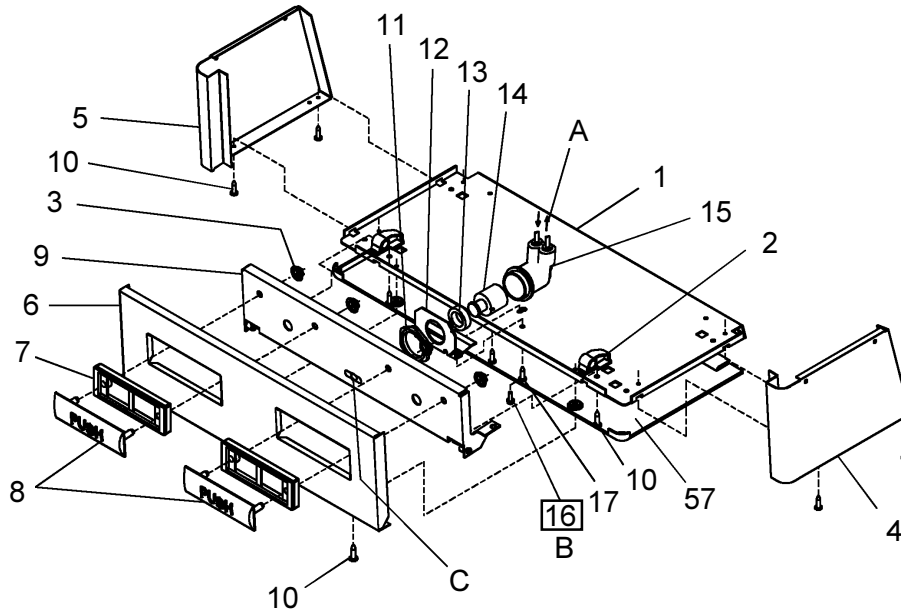

FIG. 3

**Water Valve Mechanism - ADJUSTMENT PROCEDURE:**

- Turn adjustment screw (Item 16) "Counter-Clockwise" until water flow from bubbler starts.
- Turn adjustment screw "Clockwise" until water flow stops, THEN turn an additional 1/2 turn.

**NOTE:** Adjustments stated above are viewed from underneath unit (bottom side of dispenser panel Item 1)

**NOTE:** If continuous flow occurs at the end of the compressor cycle, turn cold control (Item 48) counterclockwise 1/4 turn.

**LEGEND**

- A) Note: Water flow direction
- B) Adjust this screw to eliminate mechanism "Free Play" or continuous flow from bubbler conditions. (See ADJUSTMENT PROCEDURE)
- C) Stream height adjustment (see note #8)

**IMPORTANT  
ALL SERVICE TO BE PERFORMED BY AN  
AUTHORIZED SERVICE PERSON  
HANGER BRACKETS & TRAP  
INSTALLATION**

- 1) Remove hanger bracket fastened to back of cooler by removing one (1) screw.
  - 2) Mount the hanger bracket and trap as shown in Figure 2.
- NOTE:** Hanger Bracket **MUST** be supported securely. Add fixture support carrier if wall will not provide adequate support.

**IMPORTANT:**

- 7 in. (178mm) dimension from wall to centerline of trap must be maintained for proper fit.
  - Anchor hanger securely to wall using all six (6) 1/4 in. dia. mounting holes.
- 3) Install straight valve for 3/8" O.D. tube.

**INSTALLATION OF COOLER**

- 4) Hang the cooler on the hanger bracket. Be certain the hanger bracket is engaged properly in the slots on the cooler back as shown in Fig. 4.
- 5) Loosen the two (2) screws holding the lower front panel at the bottom of cooler base and two (2) screws at the top. Remove the front panel and set aside.
- 6) Connect water inlet line--See Note 4 of General Instructions.
- 7) Remove the slip nut and gasket from the trap and install them on the cooler waste line making sure that the end of the waste line fits into the trap. Assemble the slip nut and gasket to the trap and tighten securely.

**START UP**

**Also See General Instructions**

- 8) Stream height is factory set at 45-50 PSI. If supply pressure varies greatly from this, readjust stream height to approximately 1-1/2" (38mm) above the bubbler guard by turning adjustment screw, accessible by removing front push panel, Item No.6 (see Fig.3 & 5).
- 9) Connect to electrical supply with a ground fault circuit interrupter (GFCI) installed.
- 10) Replace the front panel and secure by retightening four (4) screws.
- 11) If a taste, odor or sediment problem is prevalent, try installing our water filter module, part no 73-15242-51-550

**PROTECT FROM FREEZING**

- 12) If the ambient air temperature drops below freezing, the cooler needs to be drained of all water by blowing out all water lines and draining the evaporator (Item #49) and the drain trap.
- 13) To drain the evaporator, remove styrofoam cap on bottom of evaporator and then remove drain plug (Item #52). See Fig.1 on the General Instructions.

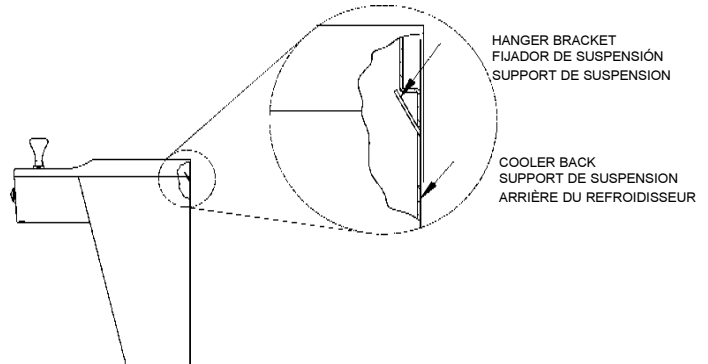
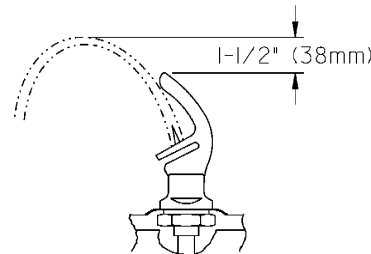

FIG. 4



**CORRECT STREAM HEIGHT**

FIG. 5

ITEMIZED PARTS LIST		
ITEM NO	PART NO	DESCRIPTION
1	22897C	Panel - Bottom Dispenser
2	51531C	Block - Pivot
3	11-14117-43-620	Nut - 1/4 - Self-Threading
4	22822C	Panel - Right Side
5	22814C	Panel - Left Side
6	22806C	Panel - Front Push
7	55859C	Pushbar - Side & Front
8	10-15143-31-640	Insert - Push Bar, Chrome
9	22900C	Bracket - Front Push
10	75499C	Screw #8 x 5/8" Lg. Torx
11	40045C	Hex Nut
12	23003C	Bracket - Regulator Mounting
13	15005C	Retaining Nut
14	61314C	Regulator
15	50986C	Holder - Regulator
16	70935C	Screw - Shoulder x 1/2" Lg.
17	75500C	Screw #10 x 1/2" Lg. Torx
18	35870C	Power Cord
19, 19a	31475C	Fan Blade
19b	30664C	Fan Blade
20	70018C	Hex Nut - Fan Blade
21, 21a	31490C	Fan Motor
21b	31491C	Fan Motor
22	70009C	Screw - (Fan Motor)
23	22899C	Shroud - Fan
24	38417001	Screw - #8-18 x 3/8" Lg. (Fan Shroud)
25	75524C	Clip (Front and Rear Panels)
26	27124C	Cover - Cold Control
27	15009C	Bubbler Nipple Assy
28	45709C	Bubbler
29	75564C	Washer - Locking
30	62152C	Condenser
31	66202C	Drier
32	22862C	Panel - Right Rear
33	22854C	Panel - Left Rear
34	22955C	Panel - Front Lower
35	10-15161-43-550	Stud - Compressor Mtg.
36	10-08067-40-570	Grommet - Compressor Mtg.
37	19037000	Clip - Compressor Mtg.
38*	35767C	Compressor Serv. Pak FF7.5HBK
38a*	35761C	Compressor Serv. Pak FF6HBK
38b*	35807C	Compressor Serv. Pak AE3425Y
38c*	35947C	Compressor Serv. Pak EM65
39	31025C	Overload/Relay 1.350.358
39a	31026C	Overload/Relay 1.350.356
39b	35801C	Relay 9660-42-166
39b	35795C	Overload MRP26ALL-69
39c	31039C	Overload/Relay P600B/427NFBYY
40, 40a	35766C	Cover - Relay
40b	30181C	Cover - Terminal
40b	30180C	Overload Spring
40b	30182C	Bale Strap
40c	35768C	Cover - Relay
41, 41b	66214C	Heat Exchanger
41a	66215C	Heat Exchanger
41c	66386C	Heat Exchanger
42	45351C	Waste Line
43	10-01471-40-560	Gasket - Drain
44	10-26399-31-640	Drain Plug
45	16-02705-08-640	Strainer Plate
46	22893C	Basin
47	10-06876-08-640	Plug Button
48	31513C	Cold Control
49	62220C	Evaporator Assembly
50	70002C	Screw - #10 x 1/2" Lg. HHSM
51	70767C	Clip - Evaporator Retaining
52	70772C	Plug - Drain
53	19-42439-01-550	Cover - Electrical Shield
54	55884C	Elbow-Drain
55	55885C	Nut 1-1/4 Slip Joint
56	55996C	Strainer
57	55931C	Cover - Dispenser Bottom
58c	35935C	Capacitor - Run
NS	40-06609-43-730	Hanger Bracket
NS	75519C	Bit-Pinned Torx T-15
NS	75520C	Bit-Pinned Torx T-25

\*REPLACE WITH SAME COMPRESSOR USED IN ORIGINAL ASSEMBLY.  
 NOTE: All correspondence pertaining to any of the above water coolers or orders for repair parts MUST include Model No. and Serial No. of cooler, name and part number of replacement part.

**Halsey Taylor**  
 2222 CAMDEN COURT  
 OAKBROOK, IL 60523  
 630.574.3500

www.DrinkingFountainDoctor.com

800-518-5388

PRINTED IN U.S.A.