

Halsey Taylor Owners Manual

Non-Refrigerated Fountains with Back Panel

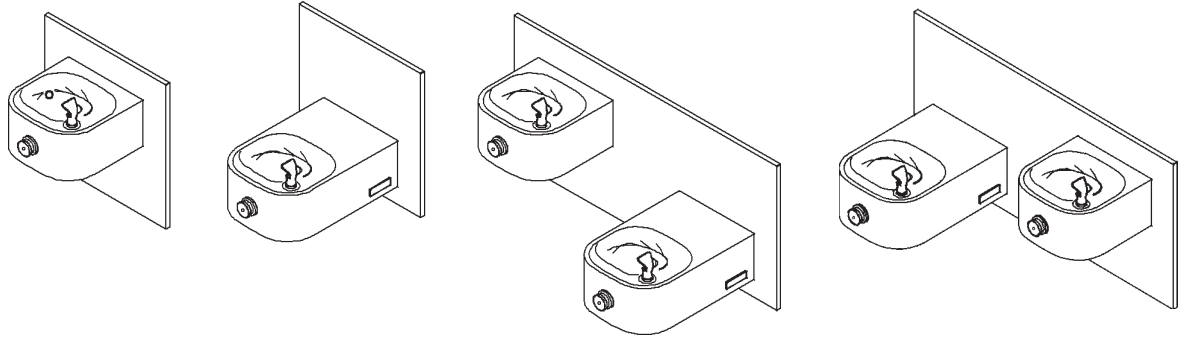

Installer

To assure you install this model easily and correctly, PLEASE READ THESE SIMPLE INSTRUCTIONS BEFORE STARTING THE INSTALLATION. CHECK YOUR INSTALLATION FOR COMPLIANCE WITH PLUMBING, ELECTRICAL AND OTHER APPLICABLE CODES. After installation, leave these instructions inside the fountain for future reference.

IMPORTANT

ALL SERVICE TO BE PERFORMED BY AN AUTHORIZED SERVICE PERSON

IMPORTANT! INSTALLER PLEASE NOTE.

THE GROUNDING OF ELECTRICAL EQUIPMENT SUCH AS TELEPHONE, COMPUTERS, ETC. TO WATER LINES IS A COMMON PROCEDURE. THIS GROUNDING MAY BE IN THE BUILDING OR MAY OCCUR AWAY FROM THE BUILDING. THIS GROUNDING CAN CAUSE ELECTRICAL FEEDBACK INTO A FOUNTAIN, CREATING AN ELECTROLYSIS WHICH CAUSES A METALLIC TASTE OR AN INCREASE IN THE METAL CONTENT OF THE WATER. THIS CONDITION IS AVOIDABLE BY USING THE PROPER MATERIALS AS INDICATED. ANY DRAIN FITTINGS PROVIDED BY THE INSTALLER SHOULD BE MADE OF PLASTIC TO ELECTRICALLY ISOLATE THE FOUNTAIN FROM THE BUILDING PLUMBING SYSTEM.

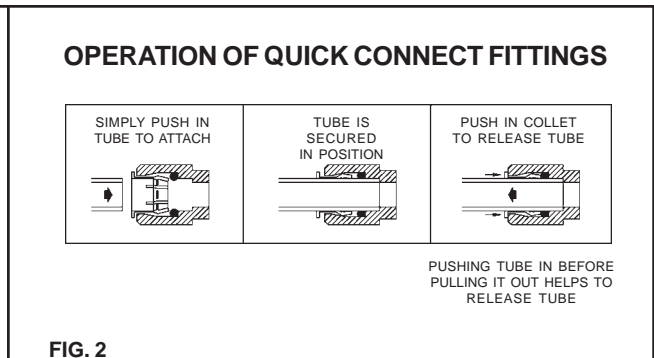
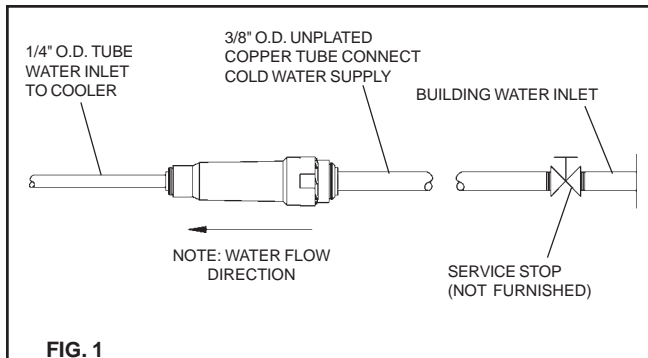

HRF - EBP / SBP / SEBP / ESBP INSTALLATION INSTRUCTIONS

1. **Wall should already be framed for the fountain** using the positioning dimensions shown in Fig's. 3, 4, 5, or 6. Shown dimensions pertain to installation location (framing must support up to 150 lbs. weight). These dimensions are required for compliance with ANSI Standard A117.0.
2. **Attach wall plate assembly to wall** as shown in Fig's. 3, 4, 5 or 6 using 5/16" x 2" long bolts and flat washers (not provided). Tighten securely. (Fastener must match wall type, i.e. lag screws for wood studs, bolts and anchors for masonry construction.)
3. **Install back panel.** Place the upper edge of the panel above hanger on the wall. Slide the panel down until it engages the hanger. Be sure back panel is firmly engaged before releasing it.
4. **Install rough-in plumbing** as shown in Fig. 3, 4, 5, or 6. Waste line should extend a minimum of 2" (51mm) thru the back panel. Run supply water inlet line thru back panel. Install a service stop (not provided). Turn on supply water and flush thoroughly.
5. **Remove bottom access panel** from fountain basin and save the screws. Install the fountain to the back panel and wall using (4) 5/16" x 3/4" long bolts and washers (provided) thru holes in back panel. Tighten securely.
4. **Cut waste tube to required length** using plumbing hardware and a trap (provided) as a guide. Install hardware and trap. Tighten securely.
5. **Make water supply connections** from service stop to the fountain strainer (See Fig. 1). Turn on water supply and check for leaks. Newly installed water supply line should be insulated after leak check is completed. **DO NOT SOLDER TUBES INSERTED INTO THE STRAINER AS DAMAGE TO THE O-RINGS MAY RESULT.**
6. **These products are designed** to operate on 20-105 PSIG supply line pressure. If inlet pressure is above 105 PSIG, a pressure regulator must be installed in the supply line. Any damage caused by reason of connecting these products to supply line pressure lower than 20 PSIG or higher than 105 PSIG is not covered by warranty.
7. **Check stream height from bubbler.** Stream height is factory set at 45-50 PSI. If supply pressure varies greatly from this, adjust the screw on regulator item 9 by using a small screwdriver through the small hole in the push button item 5 (See Fig.7). Clockwise adjustment will raise stream height and counter-clockwise adjustment will lower stream height. For best adjustment stream height should be approximately 1-1/2" (38mm) above the bubbler guard. (See Fig. 8).
8. **Replace bottom access panel** to fountain basin using screws provided. Tighten securely.

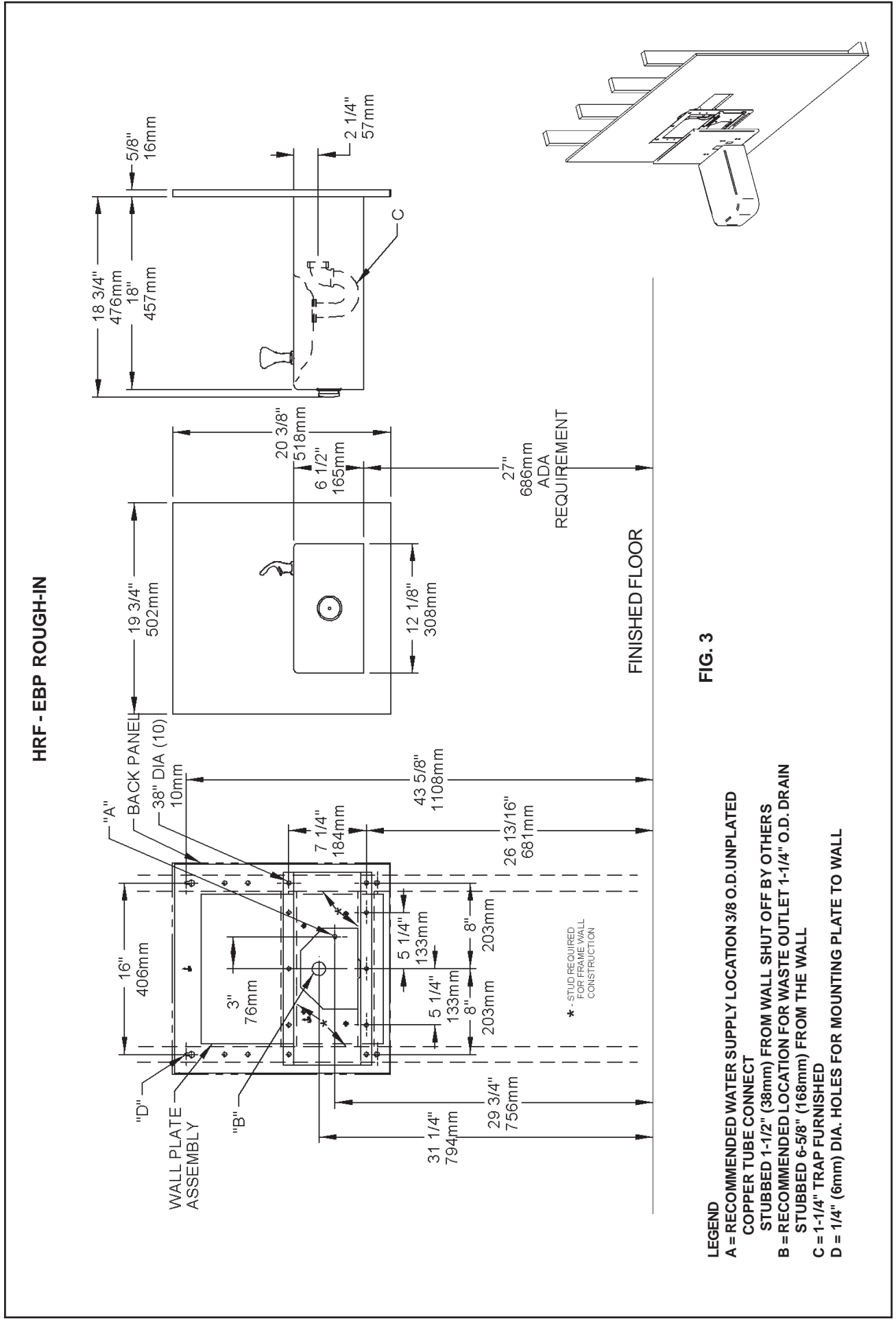

FIG. 3

LEGEND

- A = RECOMMENDED WATER SUPPLY LOCATION 3/8" O.D. UNPLATED COPPER TUBE CONNECT STUBBED 1-1/2" (38mm) FROM WALL SHUT OFF BY OTHERS
- B = RECOMMENDED LOCATION FOR WASTE OUTLET 1-1/4" O.D. DRAIN STUBBED 6-5/8" (168mm) FROM THE WALL
- C = 1-1/4" TRAP FURNISHED
- D = 1/4" (6mm) DIA. HOLES FOR MOUNTING PLATE TO WALL

HRF - SBP ROUGH-IN

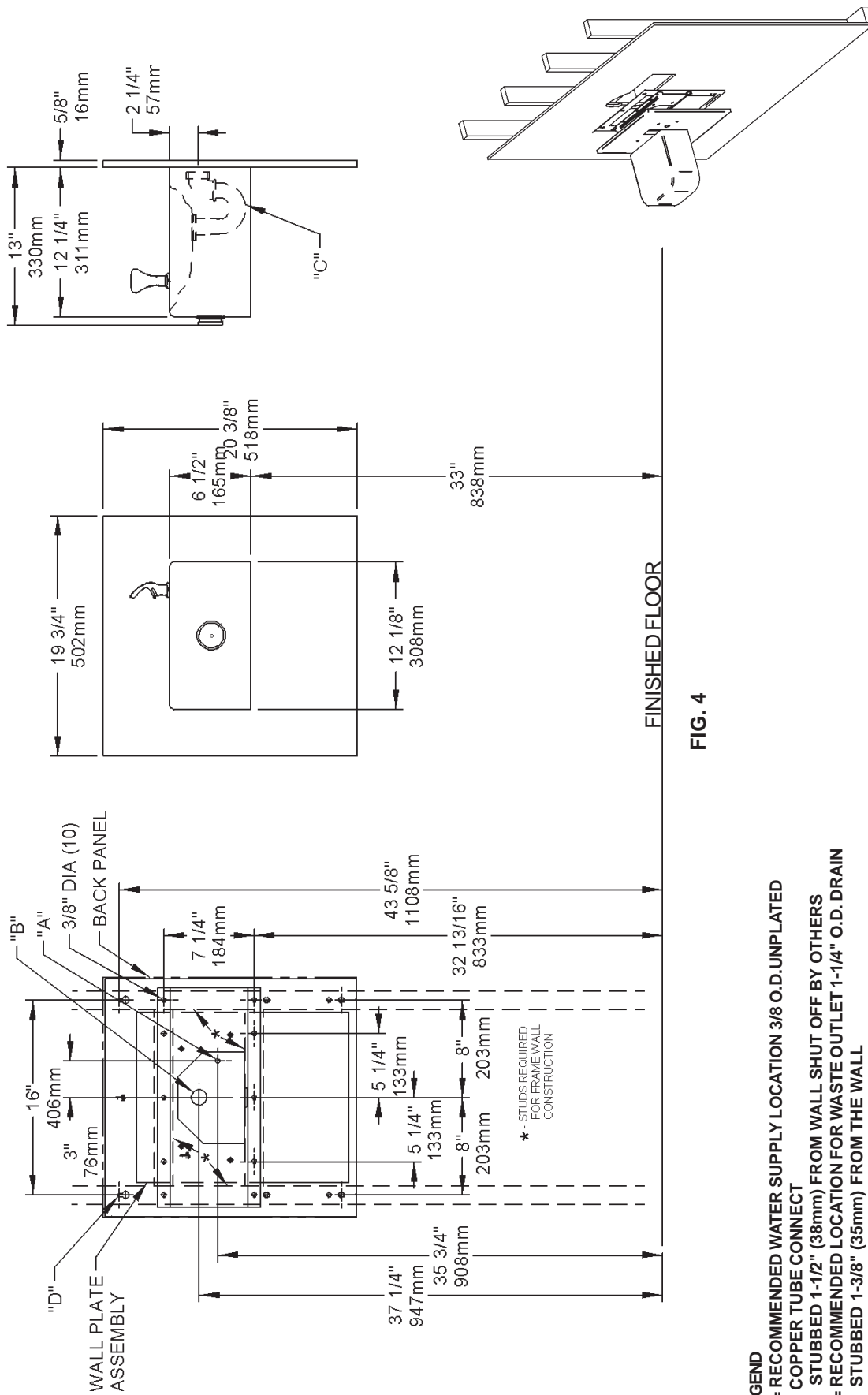
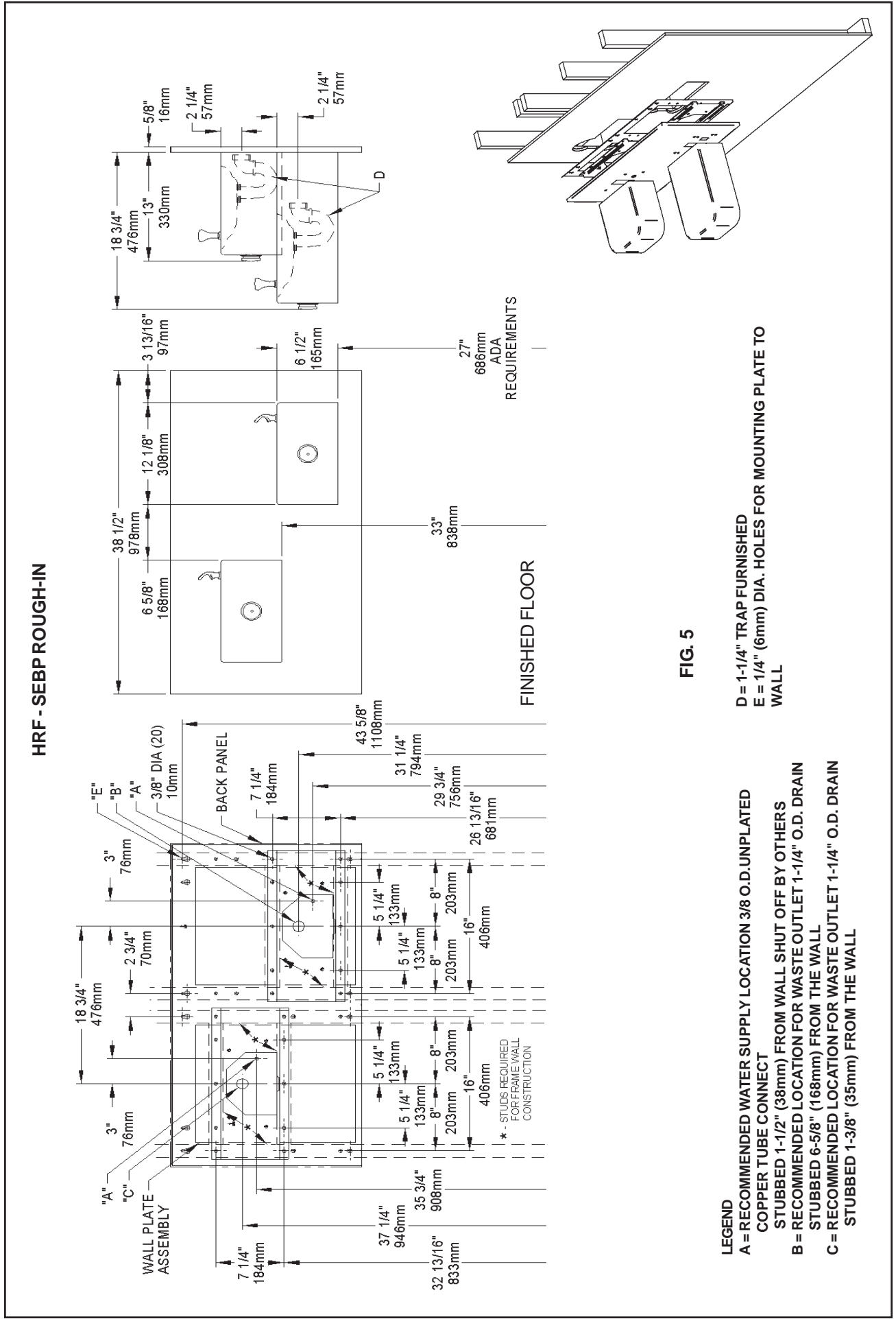

FIG. 4

- LEGEND**
- A = RECOMMENDED WATER SUPPLY LOCATION 3/8" O.D. UNPLATED COPPER TUBE CONNECT STUBBED 1-1/2" (38mm) FROM WALL SHUT OFF BY OTHERS
 - B = RECOMMENDED LOCATION FOR WASTE OUTLET 1-1/4" O.D. DRAIN STUBBED 1-3/8" (35mm) FROM THE WALL
 - C = 1-1/4" TRAP FURNISHED
 - D = 1/4" DIA. HOLES FOR MOUNTING PLATE TO WALL



HRF - SEBP ROUGH-IN

FIG. 5

D = 1-1/4" TRAP FURNISHED
 E = 1/4" (6mm) DIA. HOLES FOR MOUNTING PLATE TO WALL

LEGEND
 A = RECOMMENDED WATER SUPPLY LOCATION 3/8 O.D. UNPLATED COPPER TUBE CONNECT STUBBED 1-1/2" (38mm) FROM WALL SHUT OFF BY OTHERS
 B = RECOMMENDED LOCATION FOR WASTE OUTLET 1-1/4" O.D. DRAIN STUBBED 6-5/8" (168mm) FROM THE WALL
 C = RECOMMENDED LOCATION FOR WASTE OUTLET 1-1/4" O.D. DRAIN STUBBED 1-3/8" (35mm) FROM THE WALL

HRF-EBP*B HRF-SBP*B HRF-SEBP*B HRF-ESBP*B

PARTS LIST		
ITEM NO.	PARTNO.	DESCRIPTION
1	LK464	Drain
	LK464AG	Drain-Aztec Gold
2	15005C	Retaining Nut
3	40038C	Strainer-Beehive
	45364C	Strainer-Beehive Aztec Gold
4	40619C	Ferrule-Tailpipe
	45360C	Ferrule-Tailpipe Aztec Gold
5	45662C	Push Button
	45408C	Push Button-Aztec Gold
6	45663C	Push Button Sleeve
	45411C	Push Button Sleeve-Aztec Gold
7	50986C	Regulator Holder
8	51544C	Bubbler Assy
	45396C	Bubbler Assy-Aztec Gold
9	61313C	Regulator
10	75672C	Cap Screw
11	112627543890	Screw - #10-24 X .50 PHTC
12	55996C	Strainer
13	55001035	Fountain Arm-Short
	27571C	Fountain Arm-Short Aztec Gold
	55001038	Fountain Arm-Long
	27573C	Fountain Arm-Long Aztec Gold
14	55000661	Bottom Cover Plate-Short
	55000665	Bottom Cover Plate-Long
15	23187C	Back Panel HRF-SBP
	27583C	Back Panel HRF-SBP Aztec Gold
	23189C	Back Panel HRF-EBP
	27576C	Back Panel HRF-EBP Aztec Gold
	27043C	Back Panel HRF-SEBP
	27561C	Back Panel HRF-SEBP Aztec Gold
	27261C	Back Panel HRF-ESBP
16	40045C	Hex Nut
17	27057C	Bracket-Regulator Mounting
18	56092C	Tube-Poly (Cut to Length)
19	56159C	Assy-Bubbler Nipple
20	28158C	Wall Plate Assembly - HRF-SBP
	28159C	Wall Plate Assembly - HRF-SEBP
	28170C	Wall Plate Assembly - HRF-EBP
	28171C	Wall Plate Assembly - HRF-ESBP
21	56280C	Edge Trim
NS	75541C	Washer-Flat .339/.359ID Steel
NS	111577243890	Screw-Mach. 5/16-18 x 3/4

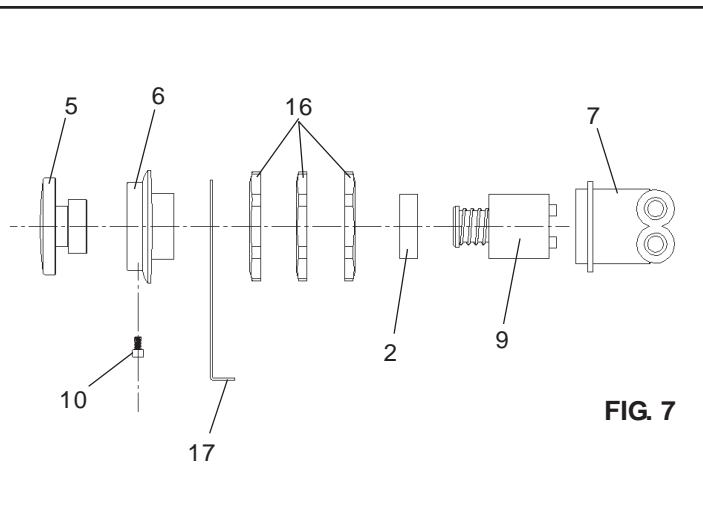

FIG. 7

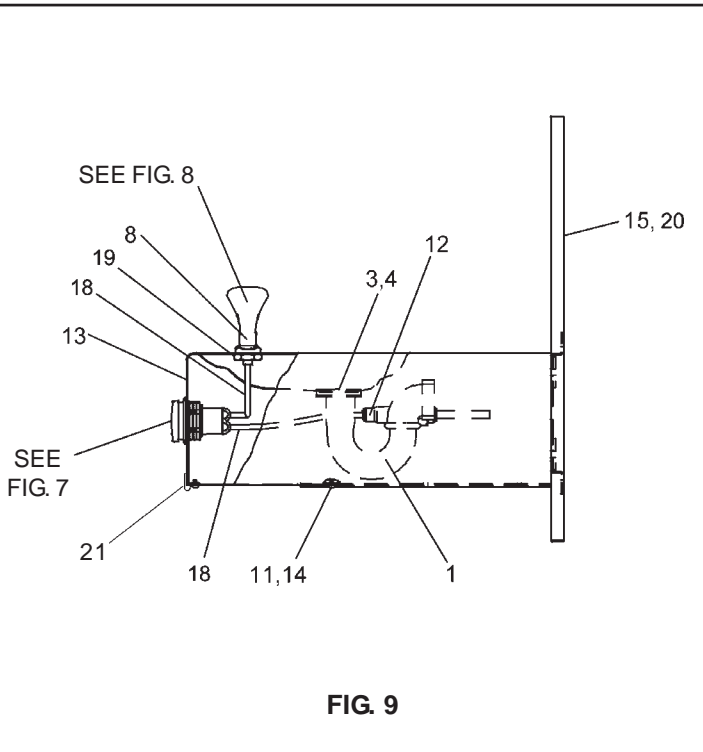

FIG. 9

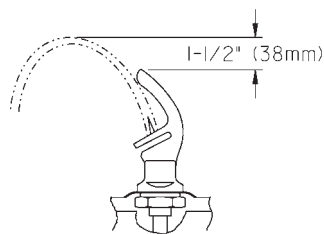

FIG. 8

TROUBLE SHOOTING & MAINTENANCE

Orifice Assy: Mineral deposits on orifice can cause water flow to spurt or not regulate. Mineral deposits may be removed from the orifice with a small round file not over 1/8" diameter or small diameter wire.

CAUTION: DO NOT file or cut orifice material.

Stream Regulator: If orifice is clean, regulate flow as in "START UP" instructions above. If replacement is necessary, see parts list for correct regulator part number.

Actuation of Quick Connect Water Fittings: Cooler is provided with lead-free connectors which utilize an o-ring water seal. To remove tubing from the fitting, relieve water pressure, push in on the gray collar while pulling on the tubing. (See Fig. 2) To insert tubing, push tube straight into fitting until it reaches a positive stop, approximately 3/4".

CAUTION: Cleaning of Aztec Gold Models requires special care. Outer surfaces must be cleaned with mild detergent or a mixture of vinegar and water only, rinsed and wiped dry. Abrasive and acidic cleaners may eventually damage the Aztec Gold finish.

Halsey Taylor
2222 CAMDEN COURT
OAK BROOK, IL 60523

www.DrinkingFountainDoctor.com

800-518-5388

PRINTED IN U.S.A.