

HALSEY TAYLOR OWNERS MANUAL

CONTOUR™ Series Electronic Eye Barrier-Free Water Coolers Refrigerated Fountains with Back Panel

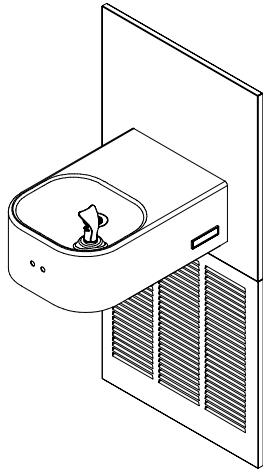

Fig.1 – HRFER-EE-Q

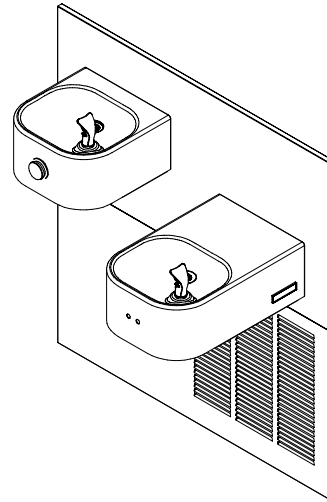

Fig. 2 – HRFSE-EE-Q

Figure	Model	Description
1	HRFER-EE-Q	Contour Series - Extended Reach
2	HRFSE-EE-Q	Contour Series - Dual Installation

INSTALLER

CAUTION: Review these instructions before beginning installation. Be sure that installation conforms to all plumbing, electrical and other applicable codes.

WARNING: When installation is complete, ensure these instructions are left in the plastic bag provided inside the installed unit for future reference.

WARNING: Service to be performed by authorized service personnel only.

NOTE: It is common practice to ground electrical hardware such as telephones, computers and other devices to available water lines. This can, however, cause electrical feedback in the plumbing circuit, which results in an “electrolysis” effect occurring in the fountain. This may result in water which has a metallic taste to it or has a noticeable increase in the metallic content of the water.

When inspecting plumbing circuit, remember the line may be grounded some distance from the installation, and may occur outside the building or area in which the unit is being installed.

This condition can be avoided (in most cases) by using recommended materials during installation. Any drain fittings provided by the installer should be made of **plastic** which will electronically isolate the fountain from the remainder of the building’s plumbing circuits.

Installation Package

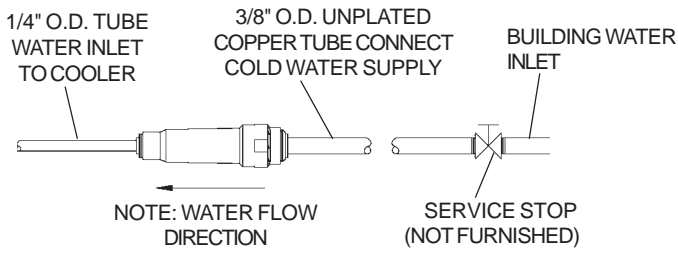

Figure 3 – Water Supply Connections

The components for installation are packed in three separate boxes, regardless of the type of unit being installed. The boxes contain the following:

- Box No. 1: Wall Frame(s)
- Box No. 2: Remote Chiller, SJ8-Q
- Box No. 3: Fountain(s), Arm(s) and Panels

Additional materials, as noted in the Parts List, are also shipped in these boxes.

Parts List Number Required

Item	Part No.	Description	HRFER-EE-Q	HRFSER-EE-Q	See Fig.
1	26837C	Upper Panel (HRFER-EE)	1	-	11, 22
	26839C	Upper Panel (HRFSER-EE)	-	1	11, 22
2	26833C	Lower Panel (HRFER-EE)	1	-	13, 22
	27026C	Lower Panel (HRFSER-EE)	-	1	13, 22
3	55001035	Standard Reach Arm	-	1	22
4	27624C	Extended Reach Arm (EE)	1	1	22
5	55000661	Bottom Cover - Standard Reach	-	1	22
	55000665	Bottom Cover - Extended Reach (EE)	1	1	22
6	100322740560	Bubbler Gasket	2	4	19
7	111008343890	Screw #10-24 x .62 HHMS	4	5	5, 8
8	111577243890	Screw 5/16-18 x .75	4	8	5, 8
9	111577343890	Hex Nut 5/16-18	4	8	5, 8
10	112627543890	Screw #10-24 x .50 PHTC	7	12	22
11	15005C	Regulator Retaining Nut	-	1	20
12	22525C	Regulator Mounting Bracket	1	1	21
13	27057C	Regulator Mounting Bracket	-	1	20
14	27240C	Support Bracket	1	1	21
15	31375C	Solenoid Valve Assy.	1	1	18
16	31376C	Power Cord	1	1	18
17	31384C	Sensor Assy.	1	1	21
18	38417001	Screw #8-18 x .37 HHSM	2	2	5, 8
19	40045C	Hex Nut	1	4	20, 21
20	45662C	Push Button	-	1	20
21	45663C	Push Button Sleeve	-	1	20
22	50203C	Strain Relief Bushing	1	1	21
23	50986C	Regulator Holder	1	2	20, 21
24	51409C	Spacer	2	2	21
25	51544C	Bubbler	1	2	19
	55905C	Bubbler - EasyFlex (Option)	1	2	19
26	56082C	Regulator Nut	1	1	26
27	56092C	Poly Tubing 1/4" (Cut To Length)	1	1	15, 16
28	56159C	Bubbler Nipple	1	2	19
29	61313C	Regulator - W/Red Spring	1	2	20, 21
30	70016C	Nut	2	2	21
31	70208C	Screw	2	2	21
32	70682C	Fitting - Tee 1/4"	-	1	16
33	70683C	Fitting - Union 1/4"	1	-	15
34	70817C	Fitting - Elbow 1/4"	1	1	18
35	70989C	Ground Screw #8-36 x .37	1	1	18

Parts List Continued

Item	Part No.	Description	HRFER-EE-Q	HRFSER-EE-Q	See Fig.
36	75507C	Fitting - 1/4" NPTF	2	2	18
37	75672C	Cap Screw #6-32 x .25	-	1	20
38	LK464	Drain Assy. (Includes items 39 thru 43)	1	2	22
39	45336C	Strainer & Ferrule Assy.	1	2	22
40	45784C	Drain Trap	1	2	22
41	45796C	Fitting - Elbow 1/4"	1	2	22
42	50074C	Tailpipe Gasket	1	2	22
43	72001527	Rubber Washer	1	2	22
44	55996C	Strainer (Supplied with Chiller)	1	1	15, 16
N-S	75674C	Allen Wrench 7/64	1	1	-

N-S means not shown

Models HRFSER-EE-Q

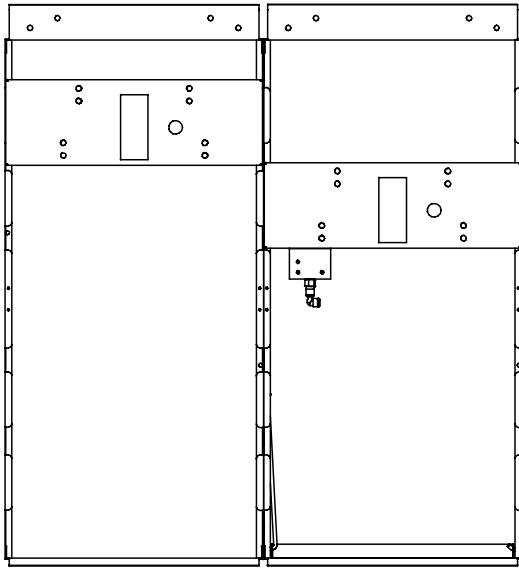

Figure 4 – HRFSER-EE-Q Rough-In

1. **Cut a rectangular wall opening** 37-1/2" (953 mm) W x 37-3/4" H (959 mm) and 4-1/2" (114 mm) above the floor line (see Figure 5). The dimensions are required to obtain proper rim and bubbler heights for compliance with ANSI standard A117.1.
2. **Reinforce the wall opening** on all sides to adequately support the water fountain. This reinforcement must support up to 150 lbs. static load and provide a means for securing the frame assembly in place.

NOTE: Building construction must allow for adequate air flow on both sides and top of remote chiller unit a minimum of 4" (102 mm) is required.
3. **Install plumbing and electrical rough-ins.** A junction box for a (3) wire, 10 amp branch circuit is provided on the inside of the chiller. (Standard 120 Volts, 60 Hz, and single phase.)
4. **Remove frames and related hardware** from packaging. Release the two shelf rods by cutting cable ties. Attach the two frames together through the upright supports with (4) 5/16" x 3/4" (19 mm) long bolts and nuts (provided). Tighten securely.

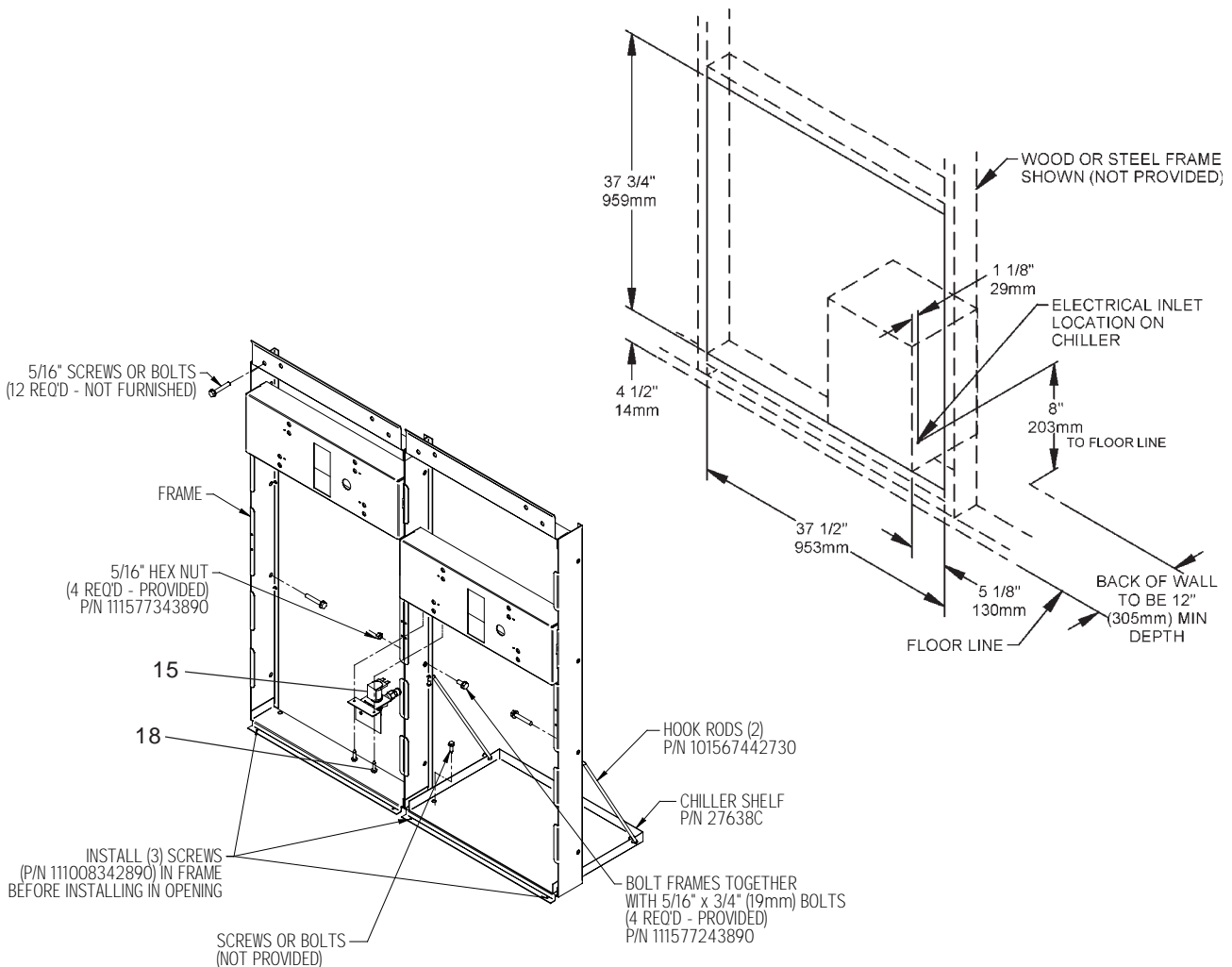

Figure 5 – Rough-In Assembly
Dual-Station Mounting Frame

5. **Install the frame assembly squarely in wall** opening with frame upright support edges flush with the finished wall face. Secure the frame to the wall through holes with (12) 5/16" bolts or screws (not provided). Tighten securely.

NOTE: Be sure that frame is squared in location. Do not use less than required screw quantity and size.

6. **Attach the chiller shelf support rods** to the right side of the frame uprights at the second set of holes counting from the bottom and to the shelf at the (2) side holes. Line up the other shelf holes with the frame bottom holes and fasten the assembly to the wall opening using appropriately sized screws or bolts and nuts (not provided).

MODEL HRFSER-EE-Q

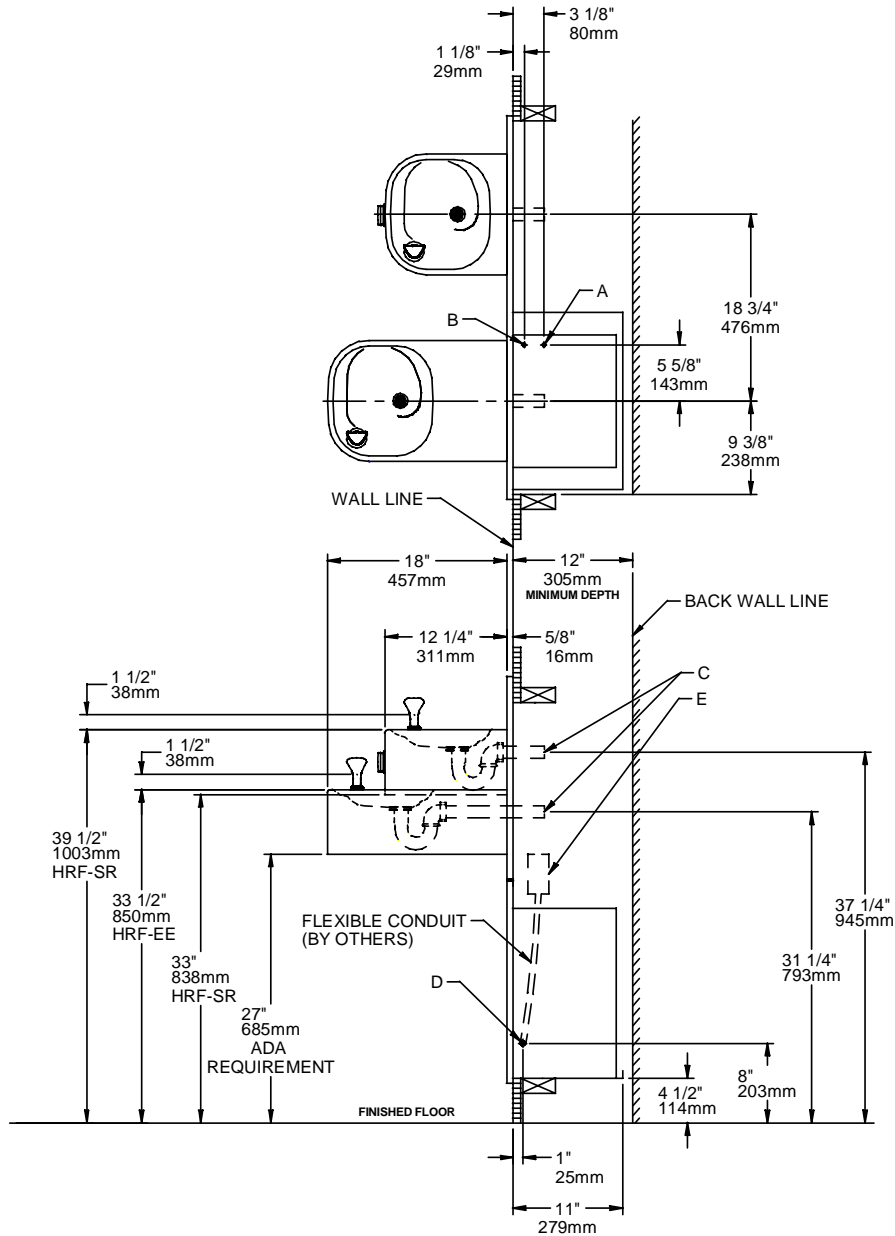

Legend

Item	Description
A	1/4" O.D. Tube - Water Outlet Connection
B	3/8" O.D. Tube - Water Inlet Connection
C	1-1/4" O.D. Waste Tube
D	Electrical Inlet on Chiller
E	Electrical Outlet Location. Additional UL/CSA listed grounded outlet (By others) required for 115 Volt, 60Hz.

Figure 6 – HRFSER-EE-Q Rough-In Dimensions

Models HRFER-EE-Q

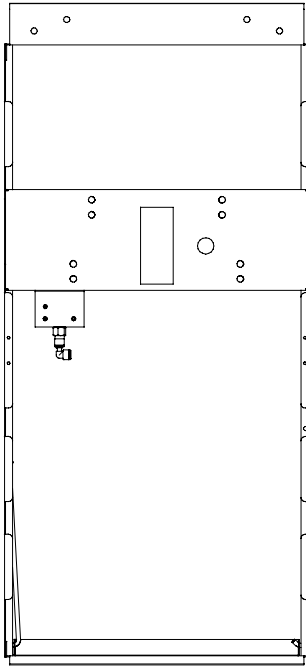

Figure 7 – HRFER-EE-Q Rough-In

1. **Cut a rectangular wall opening** 18-3/4" (475 mm) W x 37-3/4" H (959 mm) and 4-1/2" (114 mm) above the floor line (see Figure 8). The dimensions are required to obtain proper rim and bubbler heights for compliance with ANSI standard A117.1.
2. **Reinforce the wall opening** on all sides to adequately support the water fountain. This reinforcement must support up to 150 lbs. static load and provide a means for securing the frame assembly in place.
NOTE: Building construction must allow for adequate air flow on both sides and top of remote chiller unit. Minimum of 4" (102 mm) is required.
3. **Install plumbing and electrical rough-ins.** A junction box for a (3) wire, 10 amp branch circuit is provided on the inside of the chiller. (Standard 120 Volts, 60 Hz, and single phase.)
4. **Remove frame and related hardware** from packaging. Release the two shelf rods by cutting cable ties.

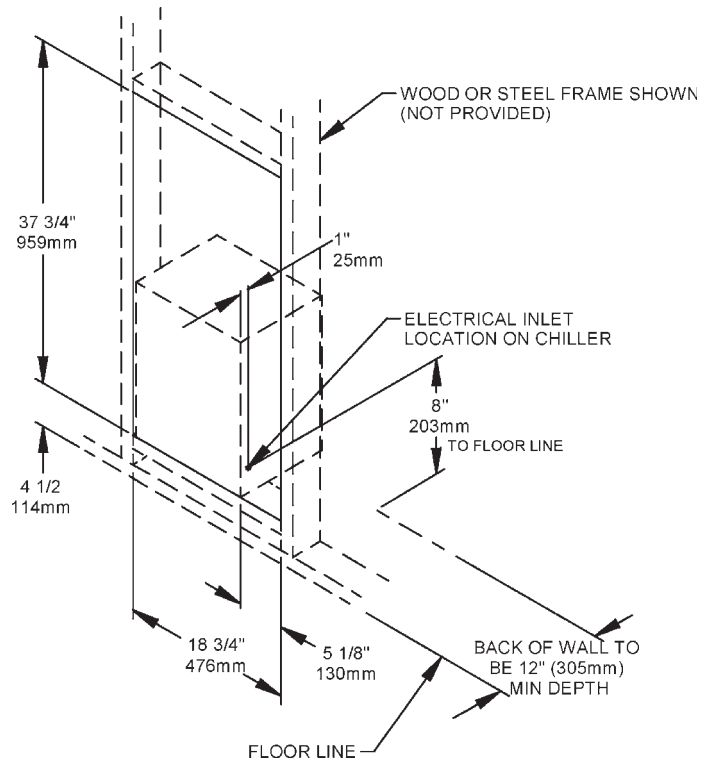
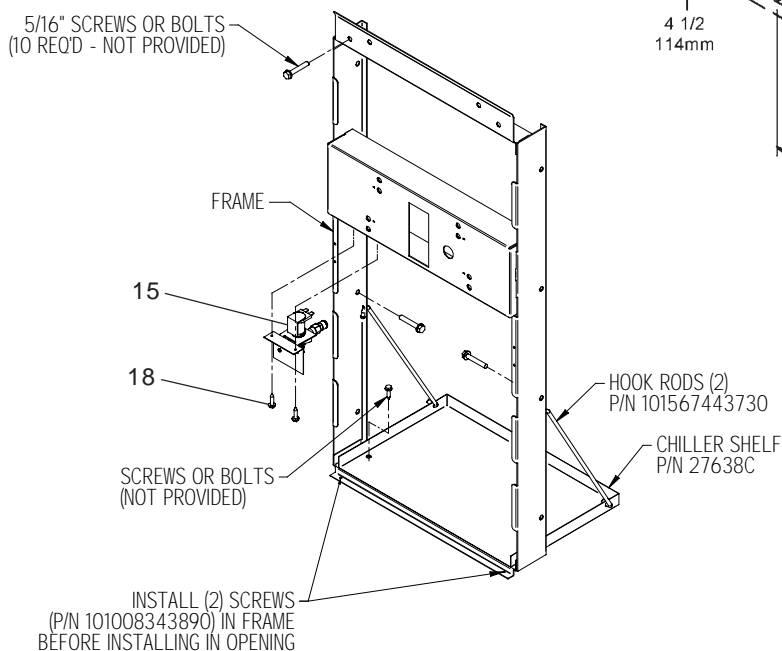

Figure 8 – Rough-In Assembly
Single-Station Mounting Frame

5. **Install the frame squarely in wall** opening with frame upright edges flush with the finished wall surface. Place shelf inside frame and line up the (2) holes on each. Insert loose ends of rods into holes on sides of shelf panel. Using appropriately sized screws or bolts (not provided), fasten the shelf and frame to the bottom of wall opening.

Secure the frame sides and top to the wall opening using (10) 5/16" bolts or screws (not provided).

NOTE: Be sure that frame is squared in location. Do not use less than the required screw quantity and size.

MODEL HRFER-EE-Q

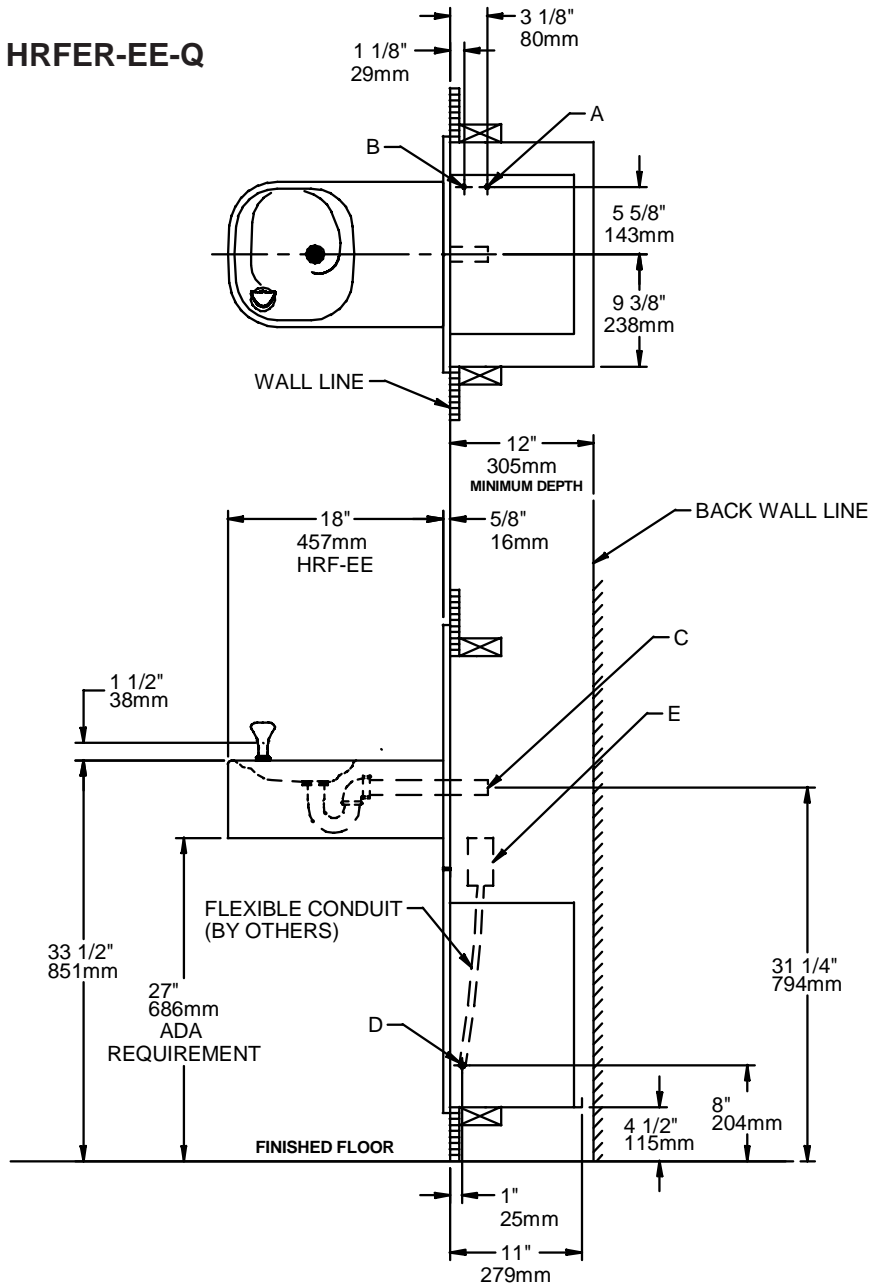

Legend

Item	Description
A	1/4" O.D. Tube - Water Outlet Connection
B	3/8" O.D. Tube - Water Inlet Connection
C	1-1/4" O.D. Waste Tube
D	Electrical Inlet on Chiller
E	Electrical Outlet Location. Additional UL/CSA listed grounded outlet (By others) required for 115 Volt, 60Hz.

Figure 9 – HRFER-EE-Q Rough-In Dimensions

REQUIRED TOOLS AND MATERIALS

These tables show special tools and/or additional materials (not provided) which are necessary to complete installation of these units:

Special Tools

Item	Description	Quantity
	None	

Additional Materials

Item	Description	Quantity
1	Unplated copper inlet pipe	
2	Service Stop	

HRFER-EE-Q/SER-EE-Q INSTALLATION

1. **Assemble and** place frame in wall as shown on preceding pages.
2. **Install chiller:** Remove front panel of chiller. **Remove and discard cardboard inner pack from between compressor and side panel.** Slide chiller onto the shelf and position it to the left on the shelf.

NOTE: Building construction must allow for adequate air flow on both sides, top and back of chiller. A minimum of 4" (102mm) on both sides and top is required. See chiller installation for additional instructions.

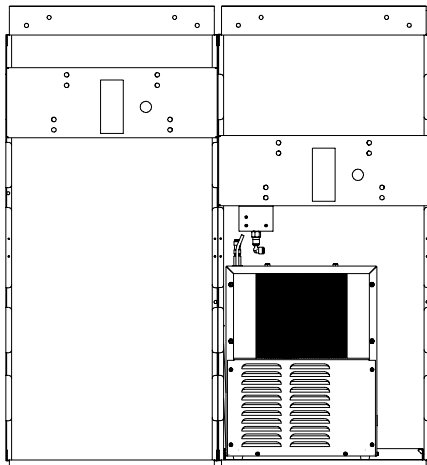

Figure 10 – Chiller Installation

3. **Attach solenoid valve assembly to the underside of cross member of mounting frame on electronic sensor unit.** (See Figs. 5 and 8).
4. **Make water supply connections.** Inlet port is marked on the chiller (1/4" O.D. copper tube). Bend the copper tube (provided) at an appropriate length from the chiller to opening in frame. Install the in-line strainer (provided with chiller) by pushing it in until it reaches a positive stop, approximately 3/4" (19mm) on the marked chiller inlet port (See Figs. 15 & 16). Attach an unplated and deburred copper water inlet line and a service stop (not provided) to the chiller. Turn on the water supply and flush the line thoroughly.
5. **Make connection between remote chiller outlet tube and solenoid valve assembly.** Outlet port is marked on the chiller (1/4" O.D. copper tube). Install a 1/4" union/tee (provided) on the marked chiller outlet port. Insert one end of 1/4" poly tubing into the union/tee and the other end into the straight fitting on the solenoid valve assy (See Figs. 15 & 16)
6. **Hang the upper panel on the mounting frame hanger.** Align holes in the panel with the holes in the mounting frame. Be sure that panel is engaged with hanger at top of frame before releasing it.

7. **Install fountain.** Remove bottom access panel on underside of fountains and **SAVE** the screws. Mount the fountains to the upper panel and frame with (4) 5/16" x 3/4" (19mm) long bolts and nuts provided. Tighten securely.

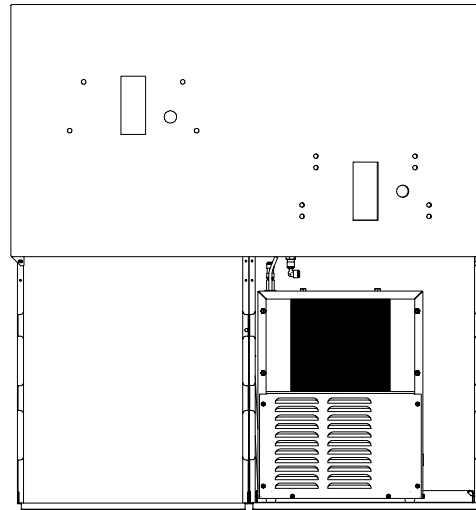

Figure 11 – Upper Panel Installation

Note: With the HRFSER-EE-Q model, the standard reach fountain must be mounted at the upper position on panel.

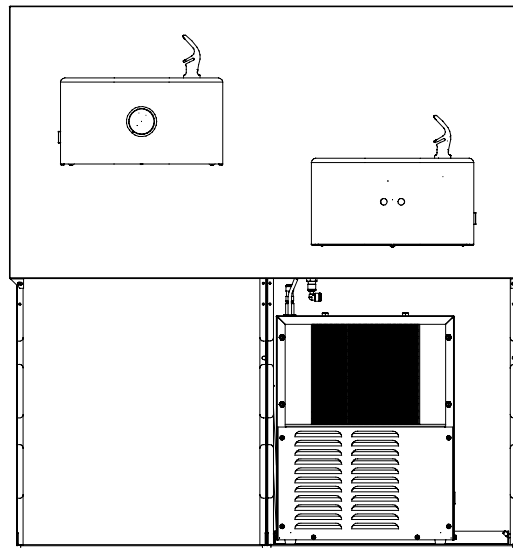

Figure 12 – Fountain Installation

8. **Connect the fountain drain waste tube to the building sanitary sewer system.** Connection should be made in compliance with local plumbing code requirements. (Note: Plumbing trap is not included with the fountain).
9. **Make connection between solenoid valve assembly and fountain(s).** Insert the 1/4" poly tubing coming from the fountain with sensor into the solenoid valve. Insert the 1/4" poly tubing coming from the fountain with push button into the tee (See Figs. 15 & 16).
10. **Connect power cord of sensor to solenoid valve by running it through the back panel and connecting it as shown in Fig. 18.** Connectors may be connected to either terminal on solenoid valve. Attach ground wire to solenoid valve bracket with green ground screw.

11. **Turn on water supply and check for leaks.** Release air from tank by interrupting infrared beam; a steady stream of water assures all air is removed. The sensor has a 30 second maximum **ON** time. It may be necessary to step away from beam a few times to allow chiller tank to fill.

CAUTION: **DO NOT SOLDER** tubes while inserted into the strainer as damage to o-rings may result.

12. **These products are designed to operate on 20-105 PSIG supply line pressure.** If inlet pressure is above 105 PSIG, a pressure regulator must be installed in the supply line.

CAUTION: Any damage caused by connecting these products to a supply line with pressure lower than 20 PSIG or higher than 105 PSIG **IS NOT** covered under warranty.

13. **Make electrical connections to the chiller.** See chiller instructions.
14. **Check stream height from bubbler.** Stream height is factory set at 35-40 PSI. If supply pressure varies greatly from this, please do the following. For **Pushbutton units only**, adjust the screw on regulator (Item 29) by using a small screwdriver through the small hole in the push button (Item 20). See Figure 20. Clockwise adjustment will raise stream height and counterclockwise movement will lower stream height. For **Electronic sensor units only**, remove bottom access panel and turn adjustment screw on the regulator (Item 29 - Fig. 21). Clockwise adjustment will raise stream height and counterclockwise movement will lower stream height. For best adjustment, stream height should be approximately 1-1/2" (38mm) above the bubbler guard. (See Figure 14).
15. **Mount lower panel.** Loosen the two (2) #10-24 x 5/8" (16mm) screws at frame bottom lip. Slide upper tongue of lower panel under lower edge of already installed upper panel. Tighten previously loosened screws securely.
16. **Replace bottom access panel** to fountain basin using screws provided. Tighten securely.

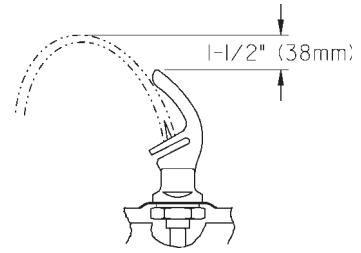

Figure 14 – Stream Height

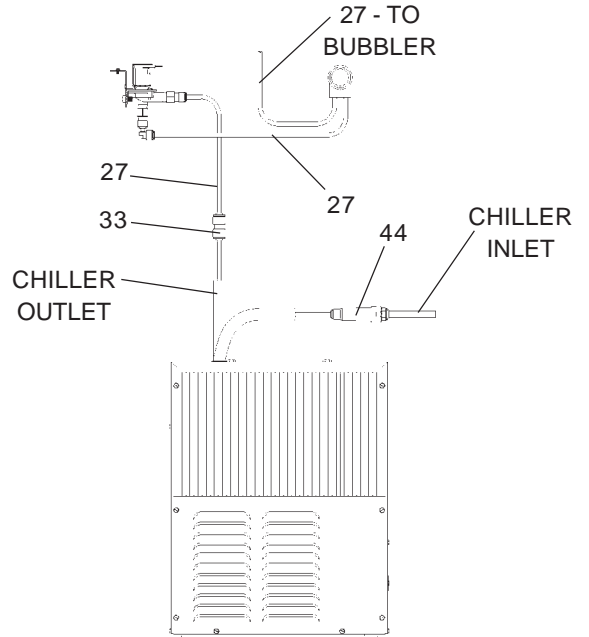

Figure 15 – HRFER-EE-Q Tube Routing

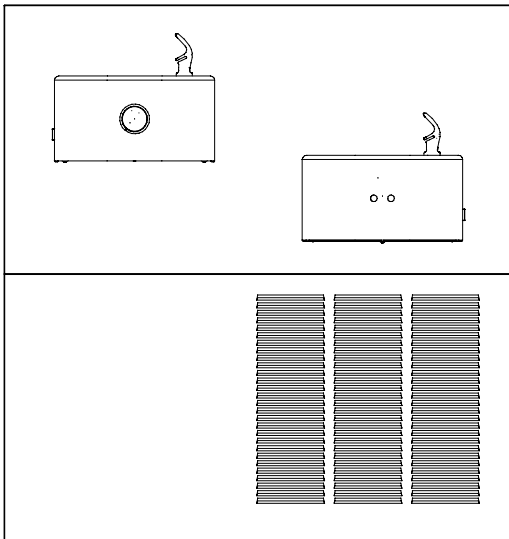

Figure 13 – Lower Panel Installation

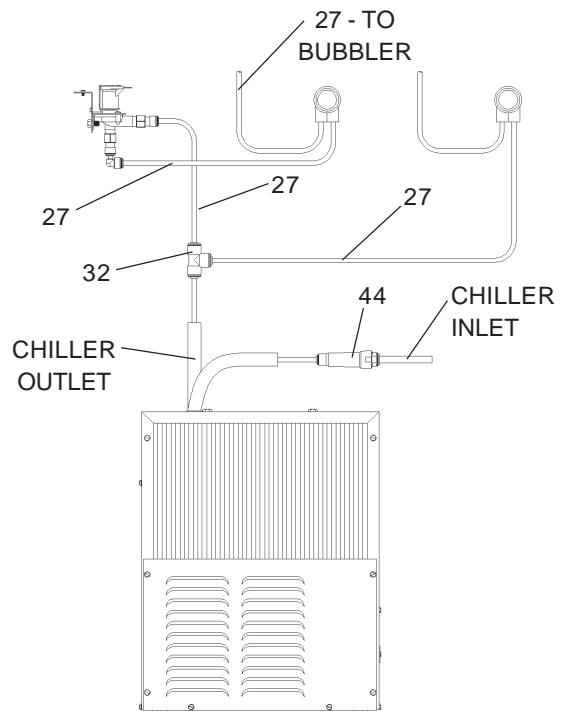

Figure 16 – HRFSER-EE-Q Tube Routing

TROUBLESHOOTING & MAINTENANCE

Orifice Assembly: Mineral deposits on orifice can cause water flow to spurt or not regulate. Mineral deposits may be removed from the orifice by poking with a small round file not over 1/8" diameter, or using a small diameter wire.

CAUTION: DO NOT file or cut orifice material.

Stream Regulator: If orifice is clean, regulate flow as in Step 14 of the installation instructions. If replacement is necessary, see parts list for correct regulator part number.

CAUTION: Cleaning of Aztec Gold Models requires special care. Outer surfaces must be cleaned with mild detergent or a mixture of vinegar and water only, rinsed and wiped dry. Abrasive and acidic cleaners may eventually damage the Aztec Gold finish.

Sensor Control: The sensor has a 2 second delay time. If sensor fails to operate valve mechanism or operates erratically, check the following:

- a) Ensure there are no obstructions within a 40 inch radius from the front of fountain.
- b) Check wire connections at the solenoid valve and at the sensor. **CAUTION:** Make sure unit is unplugged before checking any wiring.
- c) Ensure proper operation of solenoid valve. If there is an audible clicking sound yet no water flows, look for a obstruction in the valve itself or elsewhere in the water supply line. **WARNING:** Do not expose sensor to direct sunlight.

Sensor Range Adjustment: The electronic sensor used in this fountain is factory pre-set for a "visual" range of 36 inches. If actual range varies greatly from this, or a different setting is desired, follow the range adjustment procedure below:

- a) Remove bottom cover of fountain.
- b) Remove sensor by removing washers and nuts that secure sensor on studs.
- c) Locate range adjustment screw between the red lenses of the sensor, then with a small tip screwdriver, rotate the range adjusting screw clockwise to increase range or counter-clockwise to decrease range. 1/4 turn of screw is equal to approximately 12 - 18 inches of range. **CAUTION:** Complete range of sensor (24 - 46 inches) is only one turn of the adjusting screw.
- d) Remount sensor on studs and replace bottom cover.

Actuation of Quick Connect Water Fittings: Cooler is provided with lead-free connectors which utilize an o-ring water seal. To remove tubing from the fitting, relieve water pressure, push in on the gray collar while pulling on the tubing (See Figure 17). To insert tubing, push tube straight into fitting until it reaches a positive stop (approximately 3/4").

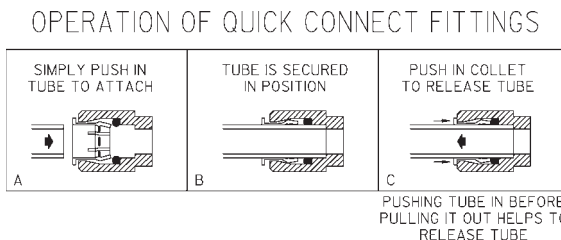

Figure 17 – Quick Connect Fittings

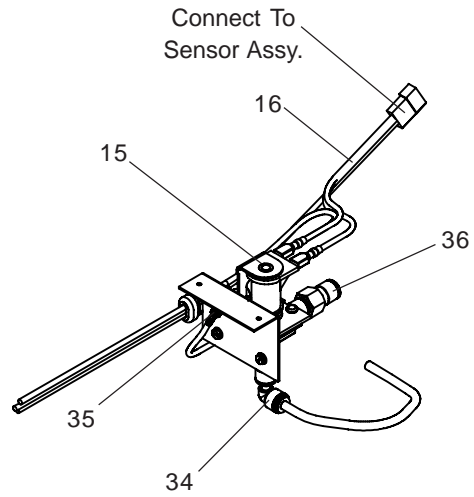

Figure 18 – View of Solenoid Valve

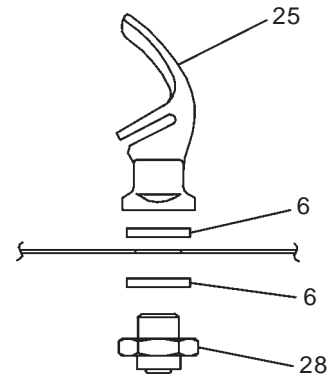

Figure 19 – View of Bubbler Assembly

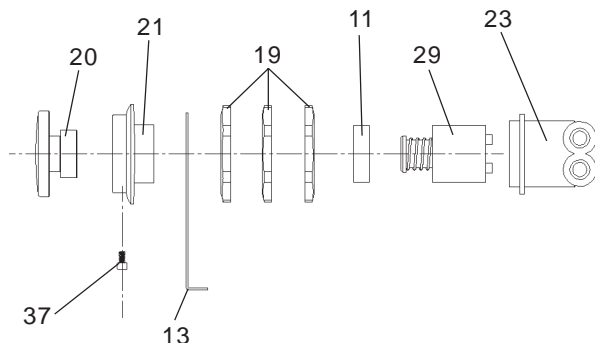

Figure 20 – Push Button/Regulator Assembly

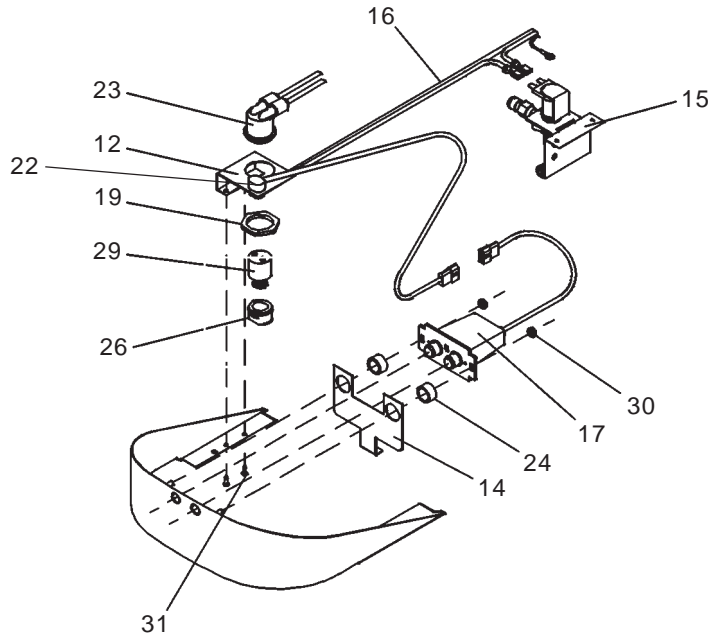

Figure 21 – Electronic Sensor Fountain Assembly

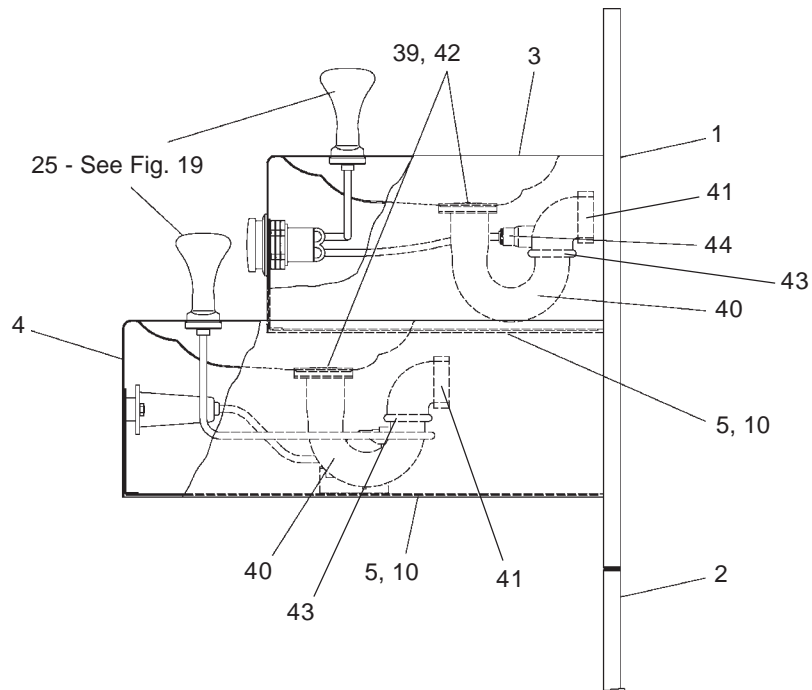

Figure 22 – Fountain Assembly - Side View

Halsey Taylor
 2222 CAMDEN COURT
 OAK BROOK, IL 60523
 630.574.3500
 PRINTED IN U.S.A.

www.DrinkingFountainDoctor.com

800-518-5388