

# Halsey Taylor Owners Manual

## Non-Refrigerated Marblyte Fountain with Back Panel

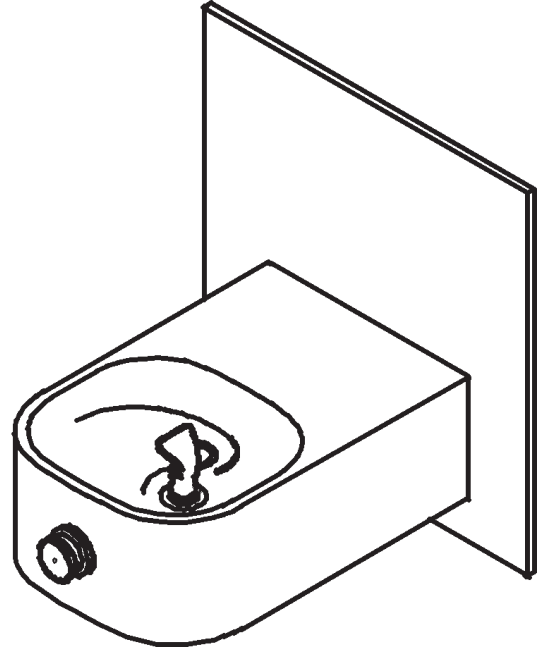

### Installer

To assure you install this model easily and correctly, PLEASE READ THESE SIMPLE INSTRUCTIONS BEFORE STARTING THE INSTALLATION. CHECK YOUR INSTALLATION FOR COMPLIANCE WITH PLUMBING, ELECTRICAL AND OTHER APPLICABLE CODES. After installation, leave these instructions inside the fountain for future reference.

### IMPORTANT

ALL SERVICE TO BE PERFORMED BY AN AUTHORIZED SERVICE PERSON

### IMPORTANT! INSTALLER PLEASE NOTE.

THE GROUNDING OF ELECTRICAL EQUIPMENT SUCH AS TELEPHONE, COMPUTERS, ETC. TO WATER LINES IS A COMMON PROCEDURE. THIS GROUNDING MAY BE IN THE BUILDING OR MAY OCCUR AWAY FROM THE BUILDING. THIS GROUNDING CAN CAUSE ELECTRICAL FEEDBACK INTO A FOUNTAIN, CREATING AN ELECTROLYSIS WHICH CAUSES A METALLIC TASTE OR AN INCREASE IN THE METAL CONTENT OF THE WATER. THIS CONDITION IS AVOIDABLE BY USING THE PROPER MATERIALS AS INDICATED. ANY DRAIN FITTINGS PROVIDED BY THE INSTALLER SHOULD BE MADE OF PLASTIC TO ELECTRICALLY ISOLATE THE FOUNTAIN FROM THE BUILDING PLUMBING SYSTEM.

HRFG-EBP, HRFG-SBP ROUGH-IN  
MARBLYTE BACK PANEL

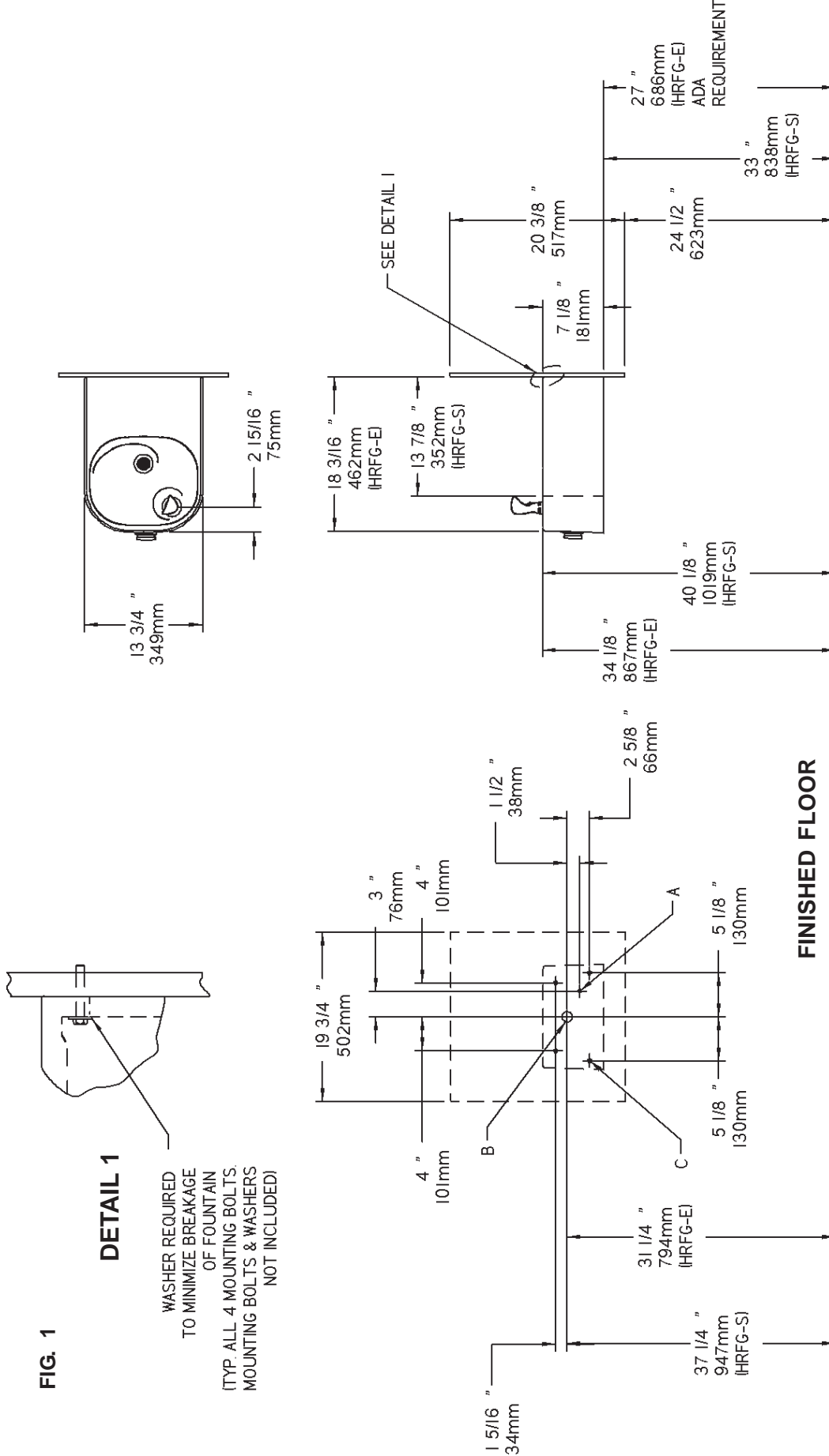

**LEGEND:**  
 A = RECOMMENDED WATER SUPPLY LOCATION 3/8 O.D. UNPLATED COPPER TUBE CONNECT  
 B = RECOMMENDED LOCATION FOR WASTE OUTLET 1-1/4" O.D. DRAIN  
 C = MOUNTING HOLES FOR SECURING FOUNTAIN TO WALL

## INSTALLATION INSTRUCTIONS MARBLYTE BACK PANEL

1. **Wall should already be framed for the fountain** using the positioning dimensions shown in Fig. 1. Shown dimensions pertain to installation location (framing must support up to 150 lbs. weight).
2. **Install rough-in plumbing** as shown in Fig. 1. Run supply water inlet line and connect to a service stop (not provided). Turn on supply water and flush thoroughly. Close water supply.
3. **Remove bottom access panel** from fountain basin and save the screws. Install the fountain to the back panel and wall using (4) 5/16" bolts and washers (not provided). Bolts should be long enough to securely fasten the fountain to the wall. Tighten securely, but do not over tighten. Over tightening will crack the Marblyte Fountain.
4. **Remove elbow from end of p-trap** (item 1) and attach it to drain tube. Re-attach elbow to p-trap and cut waste tube to required length using plumbing hardware and trap as guide.
5. **Make water supply connections** from service stop to the fountain strainer (item 16) by inserting the water inlet line into the inlet side of strainer until it reaches a positive stop about 3/4", (See Figure 6, Page 7). Turn on water supply and check for leaks. Newly installed water supply line should be insulated after leak check is completed. **DO NOT SOLDER TUBES INSERTED INTO THE STRAINER AS DAMAGE TO THE O-RINGS MAY RESULT.**
6. **These products are designed** to operate on 20-105 PSIG supply line pressure. If inlet pressure is above 105 PSIG, a pressure regulator must be installed in the supply line. Any damage caused by reason of connecting these products to supply line pressure lower than 20 PSIG or higher than 105 PSIG is not covered by warranty.
7. **Check stream height from bubbler.** Stream height is factory set at 45-50 PSI. If supply pressure varies greatly from this, adjust the screw on regulator item 14 by using a small screwdriver through the small hole in the push button item 8 (See Fig.3). Clockwise adjustment will raise stream height and counter-clockwise adjustment will lower stream height. For best adjustment stream height should be approximately 1-1/2" (38mm) above the bubbler guard (See Figure 7, Page 7).
8. **Replace bottom access panel** to fountain basin using screws provided. Tighten securely.

### Care and Maintenance of Halsey Taylor Marblyte Fountains

Marblyte provides an extremely durable, nonporous surface which resists staining. Care is very simple. Routine cleaning with a soft sponge or cloth, or with water or non-abrasive aerosol foam cleaner, is all that is normally needed to give many years of trouble free service. Cleaners left standing on the fountain surface can dull the surface finish. Be certain to rinse all cleaning agents completely and polish with a soft cloth.

Harsh abrasive cleaners are not required and should not be used.

Mild abrasives such as liquid automotive cleaning compound or baking soda paste will remove simple scratches and stains. Cigarette burns can normally be removed without noticeable effect. Deeper scratches or gouges can be corrected with fine grit sandpaper (240 grit then 400 grit) or a green Scotchbrite pad.

To maintain or regain luster and make cleaning easier, periodic applications of automobile wax or like products will keep the finish looking like new.

**HRFG-EBP, HRFGBP ROUGH-IN  
STAINLESS STEEL BACK PANEL**

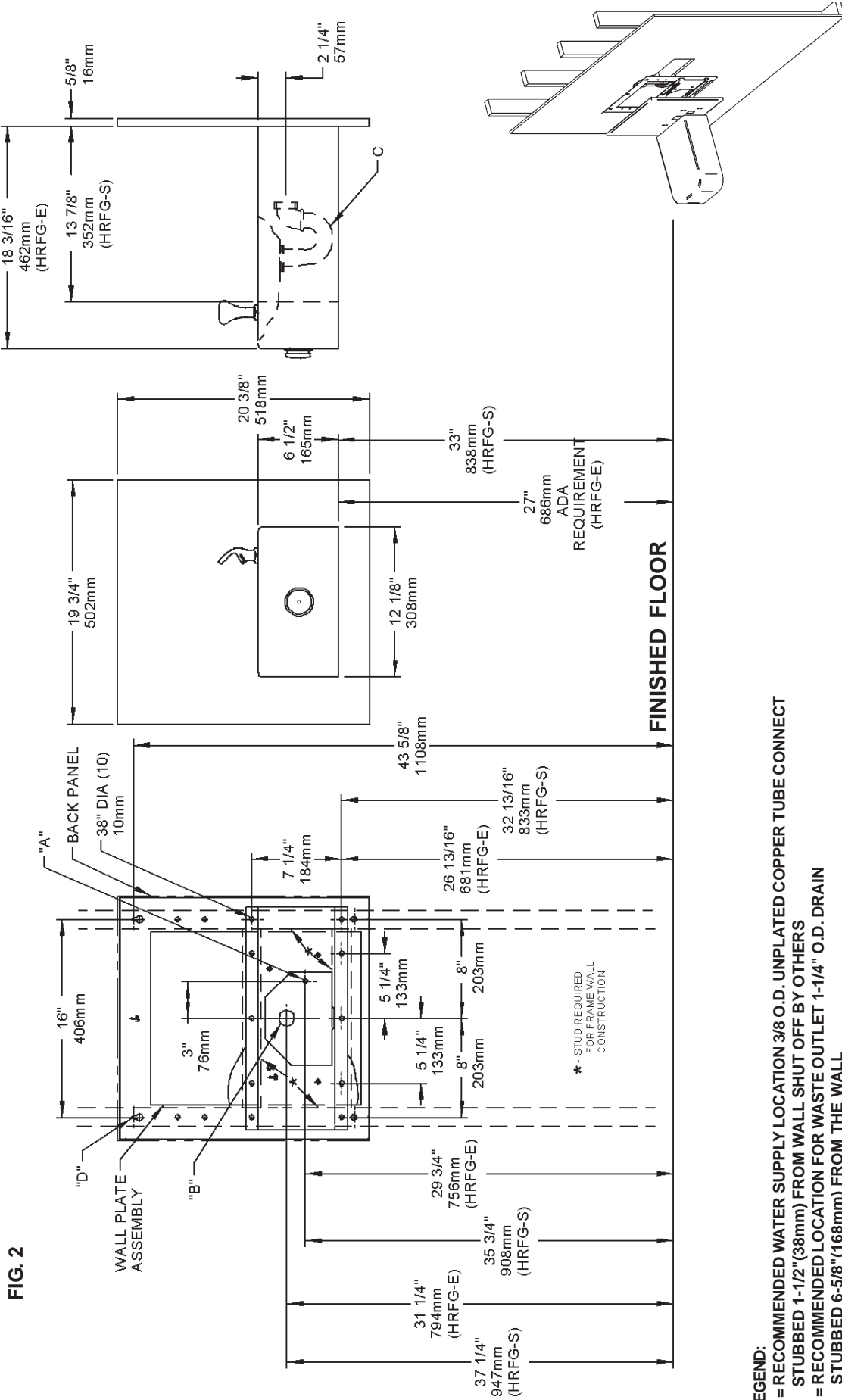

- LEGEND:**
- A = RECOMMENDED WATER SUPPLY LOCATION 3/8 O.D. UNPLATED COPPER TUBE CONNECT STUBBED 1-1/2" (38mm) FROM WALL SHUT OFF BY OTHERS
  - B = RECOMMENDED LOCATION FOR WASTE OUTLET 1-1/4" O.D. DRAIN STUBBED 6-5/8" (168mm) FROM THE WALL
  - C = 1-1/4" TRAP FURNISHED
  - D = MOUNTING HOLES FOR SECURING FOUNTAIN TO WALL (BLOCKING & WALL SUPPORT IS REQUIRED IN THESE AREA FOR PROPER SUPPORT OF FOUNTAINS)

## INSTALLATION INSTRUCTIONS STAINLESS STEEL BACK PANEL

1. **Wall should already be framed for the fountain** using the positioning dimensions shown in Fig's. 2. Shown dimensions pertain to installation location (framing must support up to 150 lbs. weight). These dimensions are required for compliance with ANSI Standard A117.0.
2. **Attach wall plate assembly to wall** as shown in Fig's. 2 using 5/16" x 2" long bolts and flat washers (not provided). Tighten securely. (Fastener must match wall type, i.e. lag screws for wood studs, bolts and anchors for masonry construction.)
3. **Install back panel.** Place the upper edge of the panel above hanger on the wall. Slide the panel down until it engages the hanger. Be sure back panel is firmly engaged before releasing it.
4. **Install rough-in plumbing** as shown in Fig. 2. Waste line should extend a minimum of 2" (51mm) thru the back panel. Run supply water inlet line thru back panel. Install a service stop (not provided). Turn on supply water and flush thoroughly.
5. **Remove bottom access panel** from fountain basin and save the screws. Install the fountain to the back panel and wall using (4) 5/16" x 1-1/4" long bolts and washers thru holes in back panel. Bolts should be long enough to securely fasten the fountain to the wall. Tighten securely, but do not over tighten. Over tightening will crack the Marblyte Fountain.
6. **Remove elbow from end of p-trap** (item 1) and attach it to drain tube. Re-attach elbow to p-trap and cut waste tube to required length using plumbing hardware and trap as guide.
7. **Make water supply connections** from service stop to the fountain strainer (item 16) by inserting the water inlet line into the inlet side of strainer until it reaches a positive stop about 3/4", (See Figure 6, Page 7). Turn on water supply and check for leaks. Newly installed water supply line should be insulated after leak check is completed. **DO NOT SOLDER TUBES INSERTED INTO THE STRAINER AS DAMAGE TO THE O-RINGS MAY RESULT.**
8. **These products are designed** to operate on 20-105 PSIG supply line pressure. If inlet pressure is above 105 PSIG, a pressure regulator must be installed in the supply line. Any damage caused by reason of connecting these products to supply line pressure lower than 20 PSIG or higher than 105 PSIG is not covered by warranty.
9. **Check stream height from bubbler.** Stream height is factory set at 45-50 PSI. If supply pressure varies greatly from this, adjust the screw on regulator item 14 by using a small screwdriver through the small hole in the push button item 8 (See Fig.3). Clockwise adjustment will raise stream height and counter-clockwise adjustment will lower stream height. For best adjustment stream height should be approximately 1-1/2" (38mm) above the bubbler guard (See Figure 7, Page 7).
8. **Replace bottom access panel** to fountain basin using screws provided. Tighten securely.

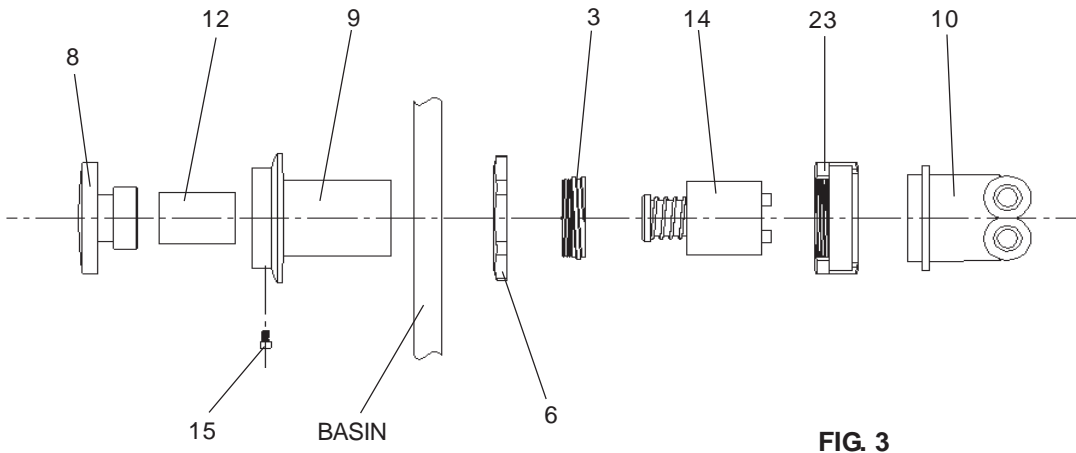

TOP VIEW

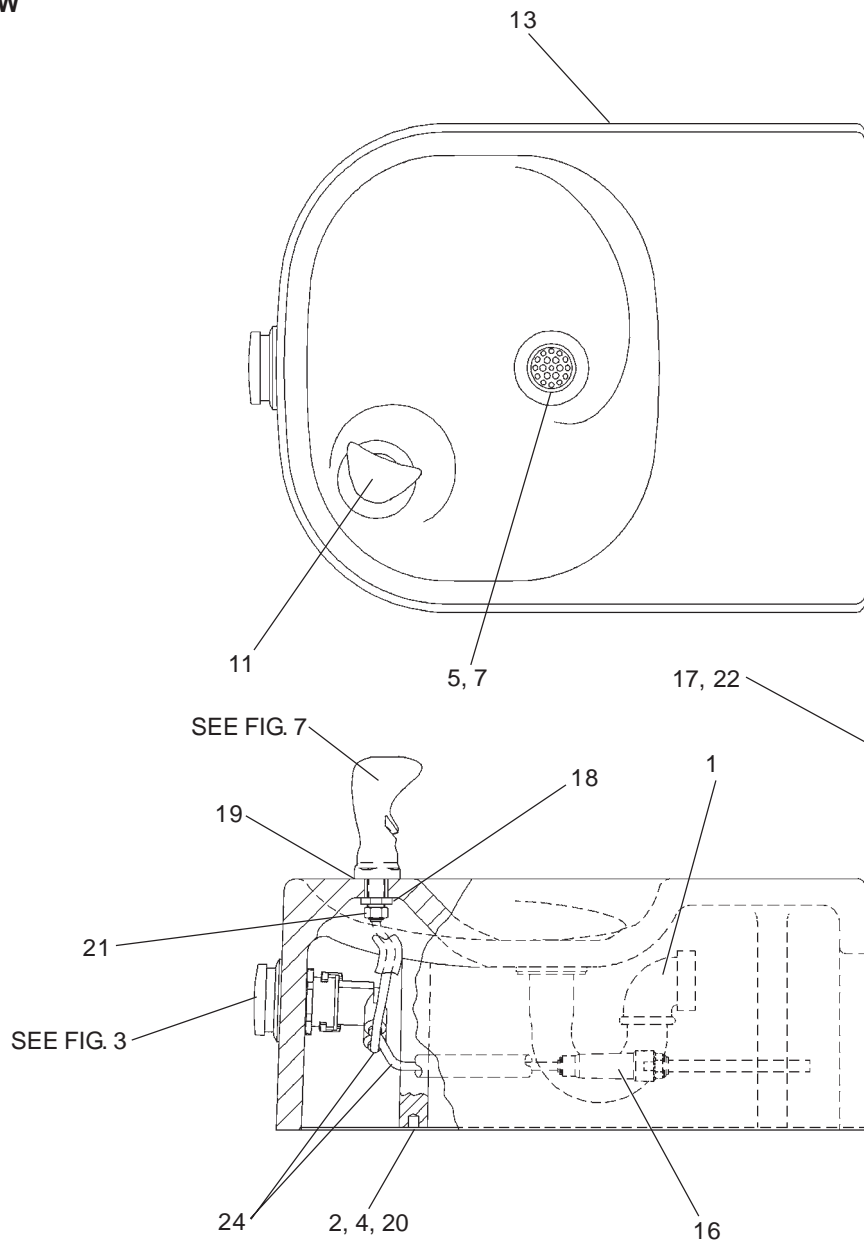

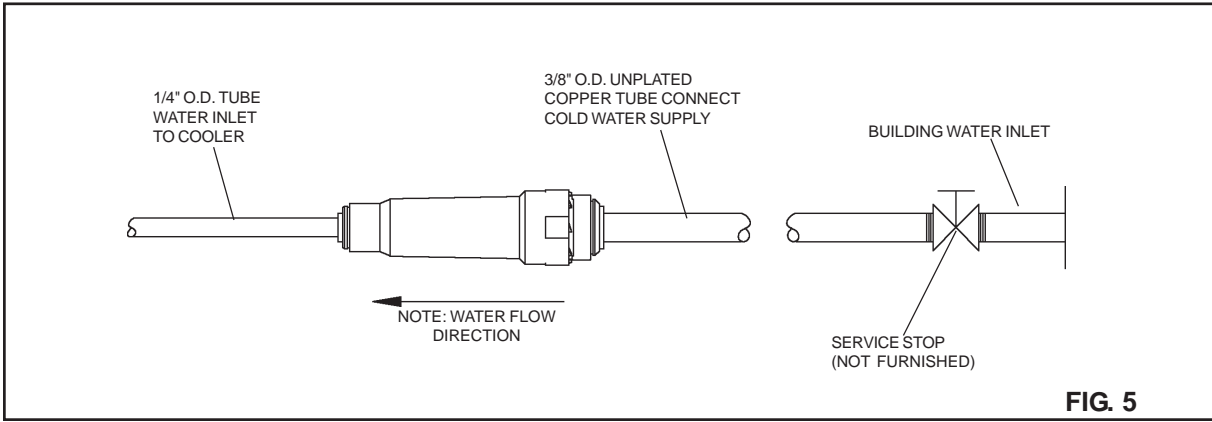

**OPERATION OF QUICK CONNECT FITTINGS**

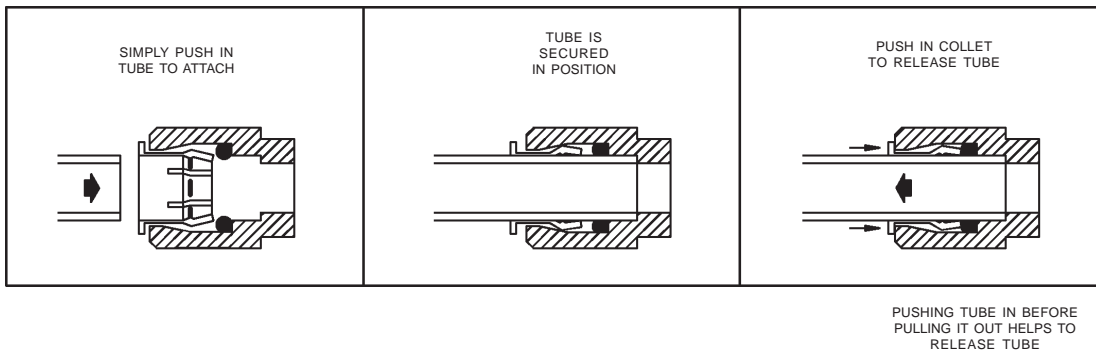

**FIG. 6**

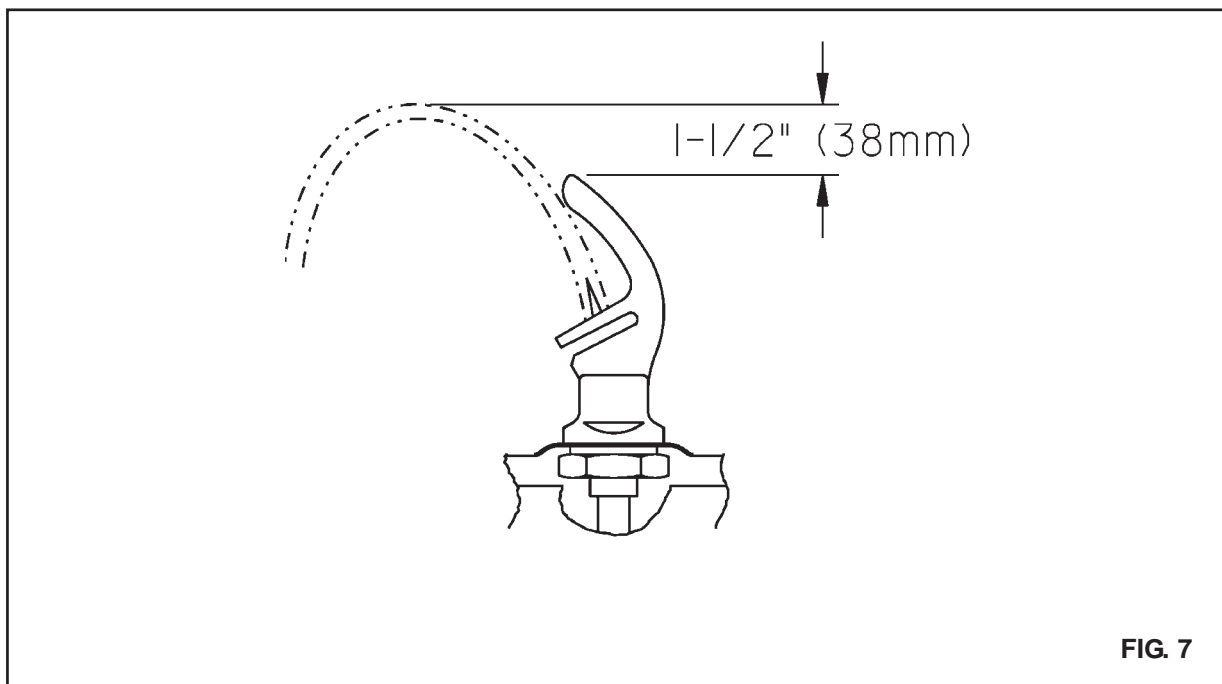

PARTS LIST		
ITEM NO.	PART NO.	DESCRIPTION
1	LK464	Drain
	LK464AG	Drain-Aztec Gold
2	112627543890	Scr, 10-24 x 1/2 PH TR HD-Z
3	15005C	Nut-reg. retain 1-1/8 - 24
4	27658C	Bottom - Plate (HRFG-E)
	27201C	Bottom - Plate (HRFG-S)
5	40038C	Strainer-Beehive
	45364C	Strainer-Beehive Aztec Gold
6	40045C	Hex - Nut
7	40619C	Ferrule-Tailpipe
	45360C	Ferrule-Tailpipe Aztec Gold
8	45662C	Push Button
	45408C	Push Button-Aztec Gold
9	45738C	Push Button Sleeve
	45750C	Push Button Sleeve-Aztec Gold
10	50986C	Regulator Holder
11	51544C	Bubbler Assy
	45396C	Bubbler Assy-Aztec Gold
12	56087C	Push Button - Extension
13	56053C	Fountain - Galaxy Gray (HRFG-E)
	55969C	Fountain - Galaxy Gray (HRFG-S)
	56057C	Fountain - Golden Sand (HRFG-E)
	55970C	Fountain - Golden Sand (HRFG-S)
	56056C	Fountain - Black (HRFG-E)
	56025C	Fountain - Black (HRFG-S)
14	61313C	Regulator
15	75672C	Cap Screw
16	55996C	Strainer
17	56028C	Panel - Back Galaxy Gray (E)
	56031C	Panel - Back Galaxy Gray (S)
	56027C	Panel - Back Black (E)
	56030C	Panel - Back Black (S)
	56029C	Panel - Back Golden Sand (E)
	56032C	Panel - Back Golden Sand (S)
	23187C	Panel - Back Stainless Steel(S)
	23189C	Panel - Back Stainless Steel(E)
18	70012C	Bubbler Locknut
19	100322740560	Gasket - Black
20	75554C	Insert - Threaded
21	15029C	Nipple Assembly
22	28158C	Wall Plate Assy HRF-SBP
	28170C	Wall Plate Assy HRF-EBP
23	45736C	Nut - Regulator Mounting
24	56092C	Poly Tubing (Cut To Length)
NS	75674C	Wrench - Allen 7/64

### TROUBLE SHOOTING & MAINTENANCE

**Orifice Assy:** Mineral deposits on orifice can cause water flow to spurt or not regulate. Mineral deposits may be removed from the orifice with a small round file not over 1/8" diameter or small diameter wire. **CAUTION: DO NOT** file or cut orifice material.

**Stream Regulator:** If orifice is free of material deposits, regulate flow as in instructions on page 3(Step 7) or page 5(Step 9). If replacement is necessary, see parts list for correct regulator part number.

**Actuation of Quick Connect Water Fittings:** Cooler is provided with lead-free connectors which utilize an o-ring water seal. To remove tubing from the fitting, relieve water pressure, push in on the gray collar while pulling on the tubing.(See Figure 6, Page 7). To insert tubing, push tube straight into fitting until it reaches a positive stop, approximately 3/4".

**CAUTION: Cleaning of Aztec Gold Models requires special care.** Outer surfaces must be cleaned with detergent or mixture of vinegar and water only, rinsed and wiped dry. Abrasive and acidic cleaners may eventually damage the Aztec Gold finish.

*Halsey Taylor*

2222 CAMDEN COURT  
OAK BROOK, IL 60523

[www.DrinkingFountainDoctor.com](http://www.DrinkingFountainDoctor.com)

800-518-5388