

# Halsey Taylor Owners Manual

Models: HT-EBP-FR    HT-SEBP-FR  
Frost Resistant Fountains

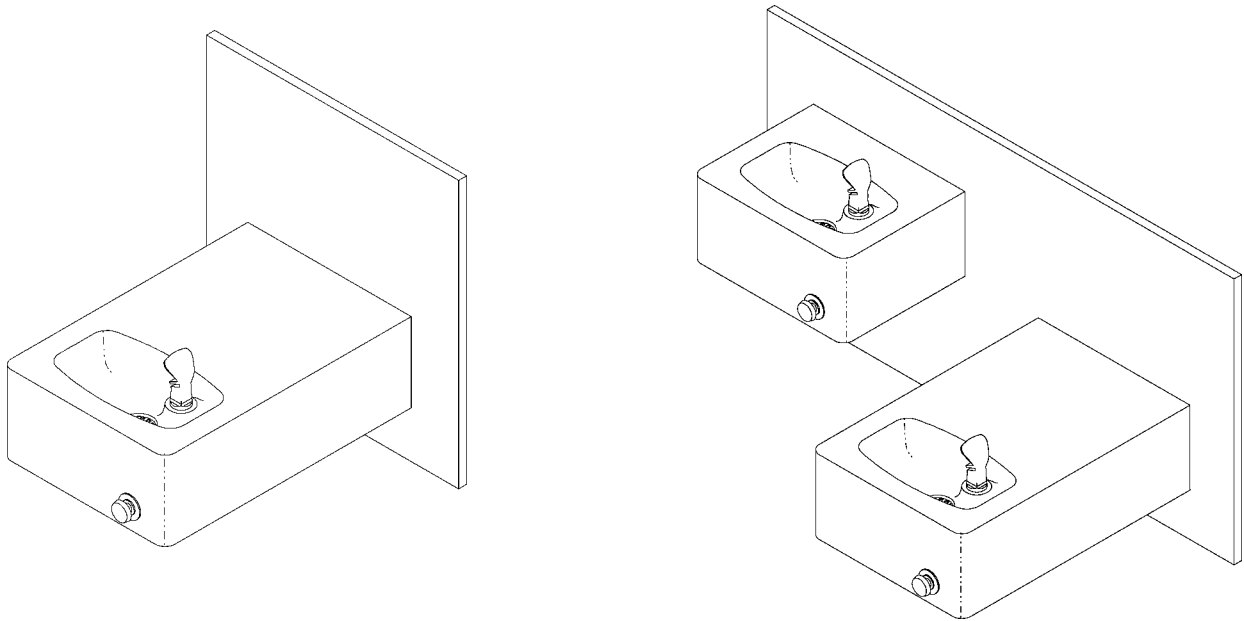

## Installer

To assure you install this model easily and correctly, PLEASE READ THESE SIMPLE INSTRUCTIONS BEFORE STARTING THE INSTALLATION. CHECK YOUR INSTALLATION FOR COMPLIANCE WITH PLUMBING, ELECTRICAL AND OTHER APPLICABLE CODES. After installation, leave these instructions inside the fountain for future reference. This Freeze Resistant Fountain is shipped in two separate cartons. The second carton contains the Freeze Resistant Package that is installed on an interior heated wall. Refer to the Freeze Resistant Package for the rough-in dimensions for installation.

## IMPORTANT

ALL SERVICE TO BE PERFORMED BY AN AUTHORIZED SERVICE PERSON

## IMPORTANT! INSTALLER PLEASE NOTE.

THE GROUNDING OF ELECTRICAL EQUIPMENT SUCH AS TELEPHONE, COMPUTERS, ETC. TO WATER LINES IS A COMMON PROCEDURE. THIS GROUNDING MAY BE IN THE BUILDING OR MAY OCCUR AWAY FROM THE BUILDING. THIS GROUNDING CAN CAUSE ELECTRICAL FEEDBACK INTO A FOUNTAIN, CREATING AN ELECTROLYSIS WHICH CAUSES A METALLIC TASTE OR AN INCREASE IN THE METAL CONTENT OF THE WATER. THIS CONDITION IS AVOIDABLE BY USING THE PROPER MATERIALS AS INDICATED. ANY DRAIN FITTINGS PROVIDED BY THE INSTALLER SHOULD BE MADE OF PLASTIC TO ELECTRICALLY ISOLATE THE FOUNTAIN FROM THE BUILDING PLUMBING SYSTEM.



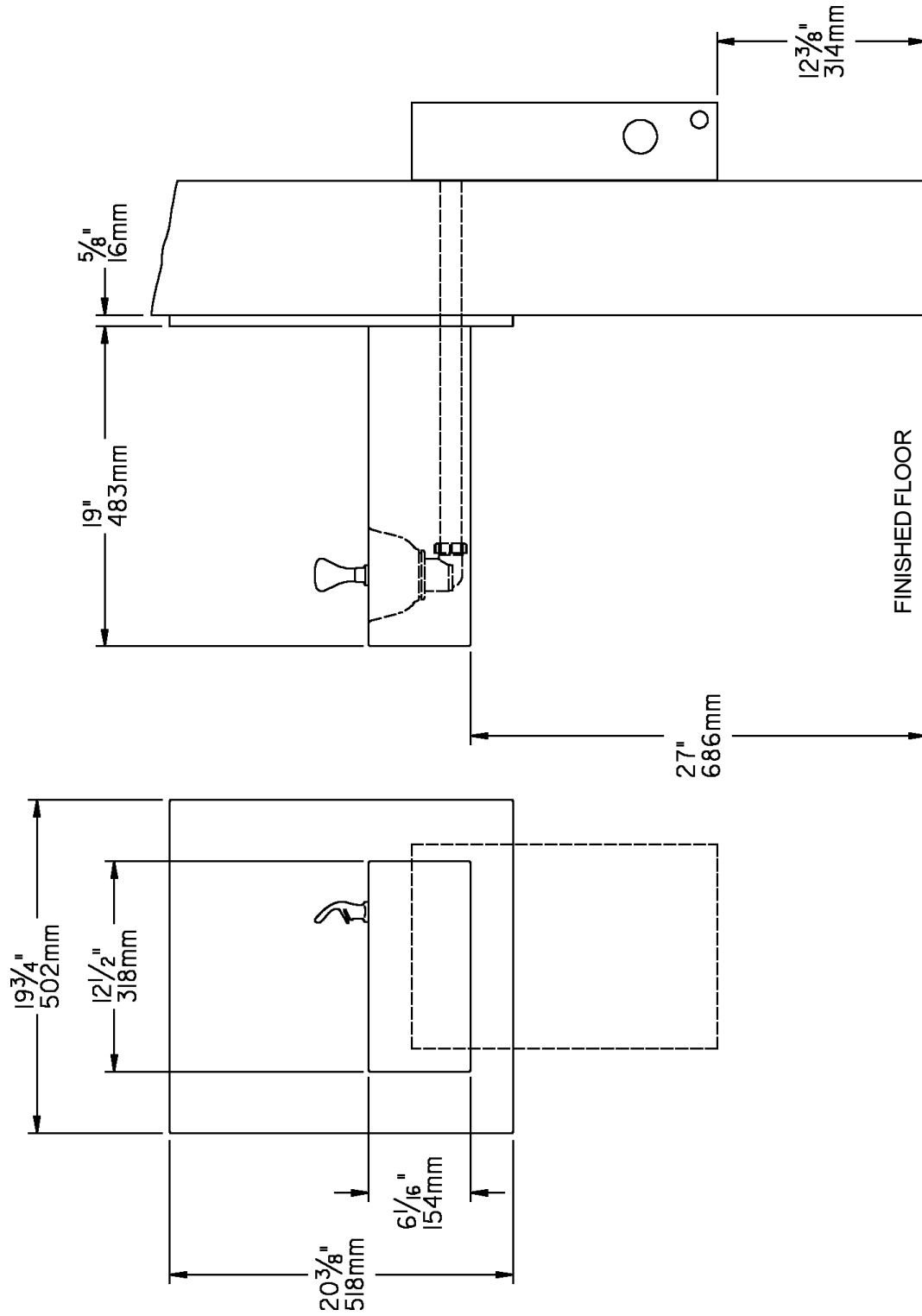

FIG 2

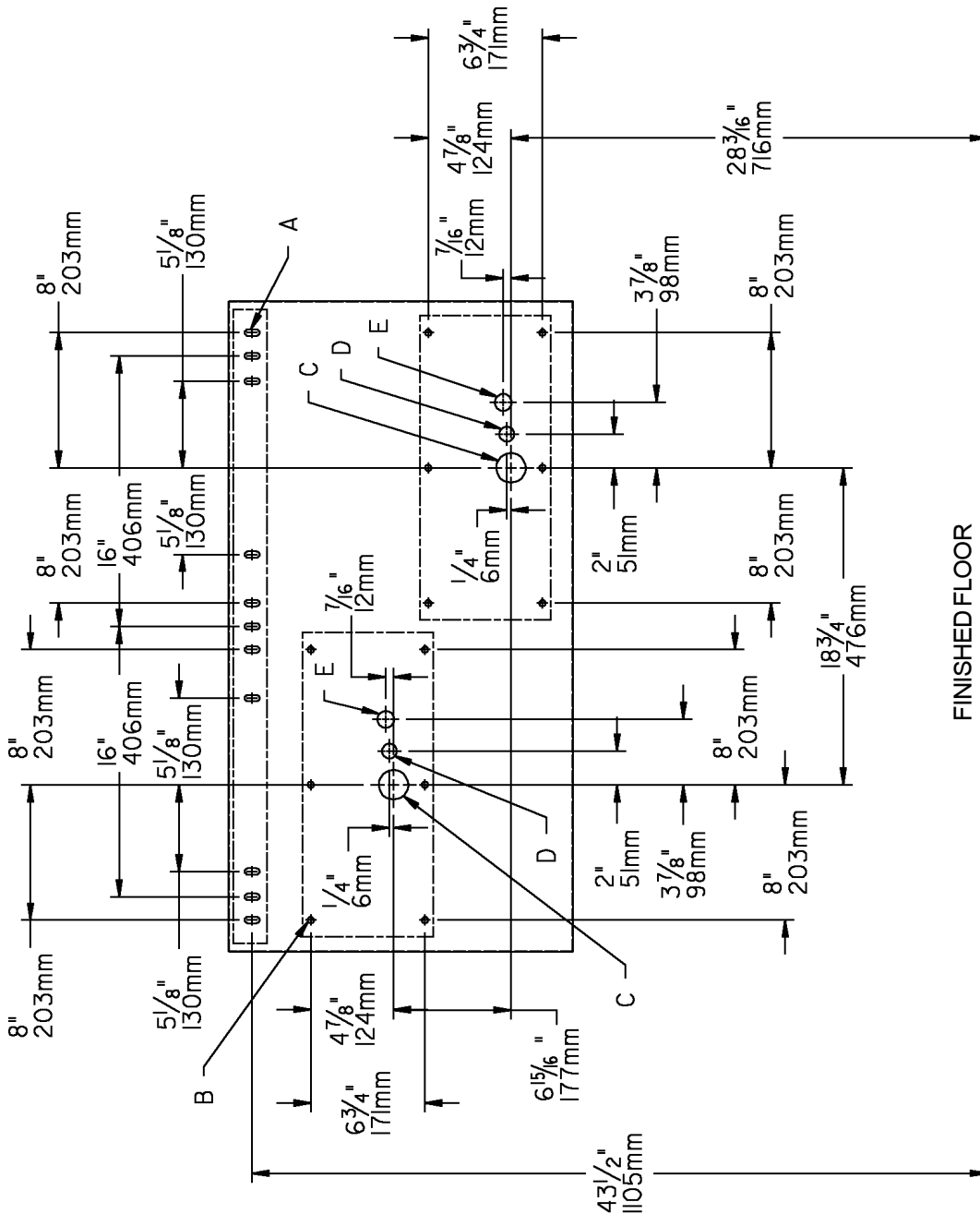

FIG. 3

- LEGEND**  
**A = 3/8" DIA. (10mm) SLOT**  
**B = 3/8" DIA. (10mm) HOLE**  
**C = 1-3/4" (44mm) HOLE FOR WASTE LINE**  
**D = 7/8" DIA. (22mm) HOLE FOR WATER INLET**  
**E = 1" DIA. (25mm) HOLE FOR PUSH ROD**

1. Wall should already be framed for the fountains using dimensions shown in Fig. 3. Shown dimensions pertain to installation location. These dimensions are required for compliance with ANSI Standard A117.1. (and ADA) (Framing shown for reference only).
2. Remove bottom covers from fountains and save the screws. Assemble push rods to fountains. (Push rods provided with frost-resistant boxes)
3. Install the fountains using bolts and washers (not provided). Tighten securely.
4. Attach drain tubes to fountains and cut to required length using the frost resistant boxes as guides.
5. Install frost-resistant boxes - see box instructions.
6. Install a service stops (not provided) and make water supply connections from the stops to the strainers in the frost-resistant boxes.
7. Connect fountain water lines to frost-resistant boxes - see box instructions. Replace bottom covers.

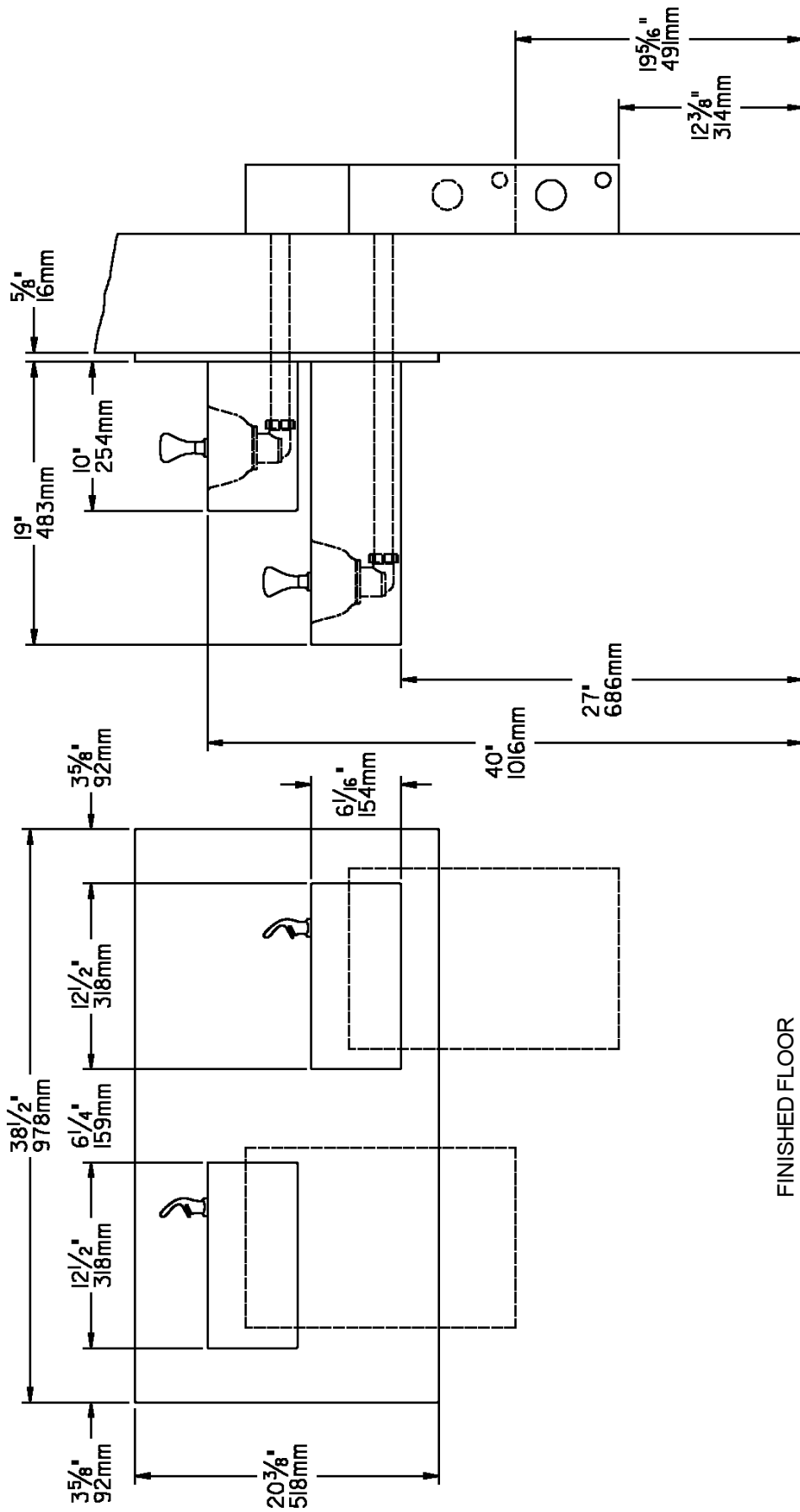
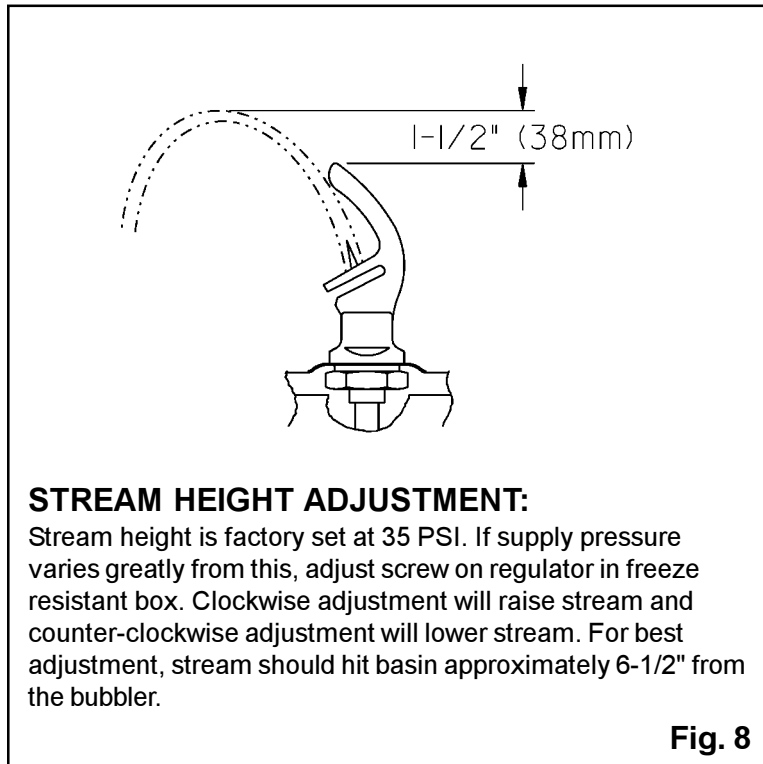
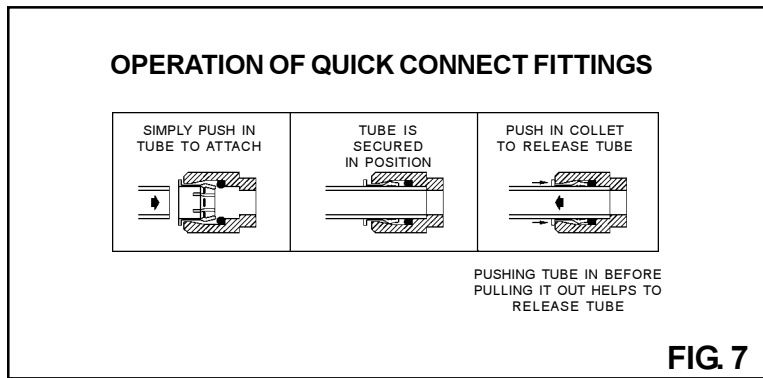
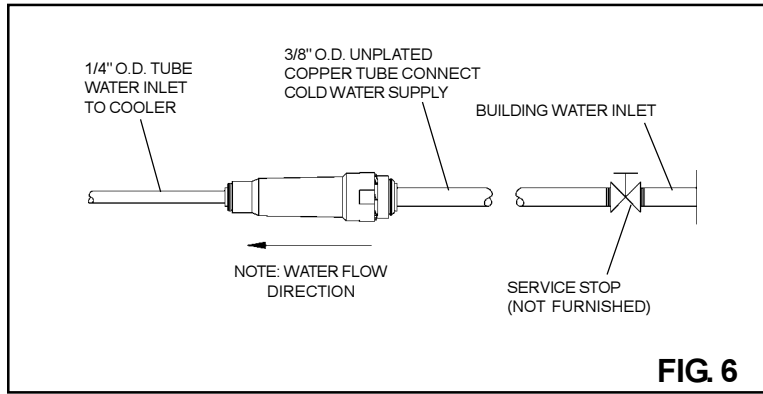

FIG. 4





## PARTS LIST

ITEM NO.	PART NO.	DESCRIPTION
1	51546C	Bubbler
2	100322740560	Gasket - Bubbler
3	66354C	Tube Assy - Bubbler (Long Ftn)
	66355C	Tube Assy - Bubbler (Short Ftn)
4	160270508640	Strainer Plate
5	161637308650	Drain Plug
6	100147140560	Gasket-Drain
7	66346C	Tube - Waste (Long Ftn)
	66343C	Tube - Waste (Short Ftn)
8	22913C	Basin (Long Ftn)
	22915C	Basin (Short Ftn)
9	23001C	Cover - Bottom (Long Ftn)
	23002C	Cover - Bottom (Short Ftn)
10	55864C	Bushing - Snap 1/2" I.D.
11	*55000458	Push Button Assy
12	*100813731870	Bushing - Snap
13	*70054C	Nut - Speed
14	55884C	Elbow-Drain
15	55885C	Nut-Slip Joint
NS	28016C	Panel - Single
NS	28017C	Panel - Double
NS	27083C	Mounting Bracket
NS	27090C	Hanger Bracket

\* PARTS SUPPLIED WITH FREEZE-RESISTANT BOX

*Halsey Taylor*  
 2222 CAMDEN COURT  
 OAK BROOK, IL 60521