

HALSEY TAYLOR OWNERS MANUAL

Classic™ Series Barrier-Free Water Coolers Refrigerated Fountains with Back Panel



Figure 1 – HTER-Q



Figure 2 – HTSR-Q

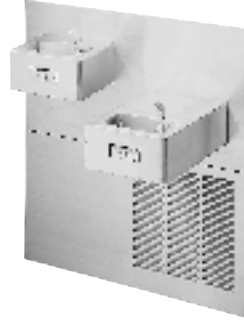

Figure 3 – HTSER-Q



Figure 4 – HTESR-Q

Figure	Model	Description
1	HTER-Q	Classic™ Series - Extended Reach
2	HTSR-Q	Classic™ Series - Standard Reach
3	HTSER-Q	Classic™ Series - Dual Installation
4	HTESR-Q	Classic™ Series - Dual Installation

INSTALLER



CAUTION:

Review these instructions before beginning installation. Be sure that installation conforms to all plumbing, electrical and other applicable codes.



WARNING:

When installation is complete, ensure these instructions are left in the plastic bag provided inside the installed unit for future reference.



WARNING:

Service to be performed by authorized service personnel only.

NOTE: It is common practice to ground electrical hardware such as telephones, computers and other devices to available water lines. This can, however, cause electrical feedback in the plumbing circuit, which results in an “electrolysis” effect occurring in the fountain. This may result in water which has a metallic taste to it or has a noticeable increase in the metallic content of the water.

When inspecting plumbing circuit, remember the line may be grounded some distance from the installation, and may occur outside the building or area in which the unit is being installed.

This condition can be avoided (in most cases) by using recommended materials during installation. Any drain fittings provided by the installer should be made of **plastic** which will electronically isolate the fountain from the remainder of the building’s plumbing circuits.

HTERQ*E HTSRQ*E HTESRQ*K HTSERQ*K

Installation Package

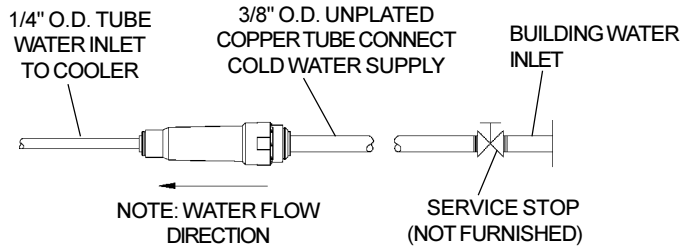

The components for installation are packed in three separate boxes, regardless of the type of unit being installed. The boxes contain the following:

- Box No. 1: Wall Frame(s)
- Box No. 2: Remote Chiller, SJ8-Q
- Box No. 3: Fountain(s), Arm(s) and Panels

Additional materials, as noted in the Parts List, are also shipped in these boxes.

Figure 5 – Water Supply Connections

Parts List **Number Required**

Item	Part No.	Description	HTER-Q	HTSR-Q	HTESR-Q	HTSER-Q	See Fig.
1	51546C	Bubbler	1	1	2	2	17, 18
2	66318C	Bubbler Tube Assembly	1	1	2	2	18
3	10080C	Bubbler Nipple (Included w/Item 2)	1	1	2	2	18
4	100322740560	Bubbler Gasket	2	2	4	4	18
5	160270508640	Strainer Plate	1	1	2	2	18
6	161637308640	Drain Plug	1	1	2	2	18
7	100147140560	Drain Gasket	1	1	2	2	18
8	66346C	Waste Tube (HT-ER)	1	-	1	1	18
	66343C	Waste Tube (HT-SR)	-	1	1	1	18
9	28316C	Basin - Stainless Steel (HT-ER)	1	-	1	1	18
	28317C	Basin - Stainless Steel (HT-SR)	-	1	1	1	18
10	23001C	Bottom Cover (HT-ER)	1	-	1	1	18
	23002C	Bottom Cover (HT-SR)	-	1	1	1	18
11	26837C	Upper Panel (HT-ER)	1	-	-	-	18
	26835C	Upper Panel (HT-SR)	-	1	-	-	18
	27028C	Upper Panel (HT-ESR)	-	-	1	-	18
	26839C	Upper Panel (HT-SER)	-	-	-	1	18
12	26833C	Lower Panel (HT-ER/SR)	1	1	-	-	18
	27026C	Lower Panel(HT-ESR/SER)	-	-	1	1	18
13	56121C	Drain Elbow	1	1	2	2	18
14	75588C	Nut - 1-1/4" Slip Joint	1	1	2	2	18
15	75589C	Washer - Seal	1	1	2	2	18
16	55996C	Strainer (Supplied with Chiller)	1	1	1	1	5, 19, 20
17	70682C	Tee - 1/4"	-	-	1	1	20
18	70683C	Union - 1/4"	1	1	-	-	19
19	56092C	Poly Tubing (Cut To Length)	1	1	1	1	19, 20
20	26901C	Push Lever	1	1	2	2	15
21	26935C	Mounting Bracket Assy	1	1	2	2	15
22	27237C	Bracket - Pushbar	1	1	2	2	15
23	75517C	Lever Rod	1	1	2	2	15
24	70378C	Pushbar Rod	1	1	2	2	15
25	75555C	Spring Clip	1	1	4	4	15
26	75504C	Screw - #10-24 x .38 PHMS	1	1	2	2	15
27	55859C	Pushbar - Side & Front	1	1	2	2	15
28	101514331640	Pushbar Insert	1	1	2	2	15
29	111411743620	Nut - 1/4 Self Thread	2	2	4	4	15
30	40045C	Regulator Hex Nut	1	1	2	2	15
31	15005C	Regulator Retaining Nut	1	1	2	2	15
32	61313C	Regulator	1	1	2	2	15
33	50986C	Regulator Holder	1	1	2	2	15

HTERQ*E HTSRQ*E HTESRQ*K HTSERQ*K

Item	Part No.	Description	HTER-Q	HTSR-Q	HTESR-Q	HTSER-Q	See Fig.
34	50198C	Snap Bushing	8	8	16	16	15
35	55899C	Pad - Window Filler	1	1	2	2	15
36	27073C	Backing Plate	1	1	2	2	15
37	70055C	Speed Nut	1	1	2	2	15
NS	112627543890	Screw 10-24 x 1/2 PHTC	10	10	20	20	-

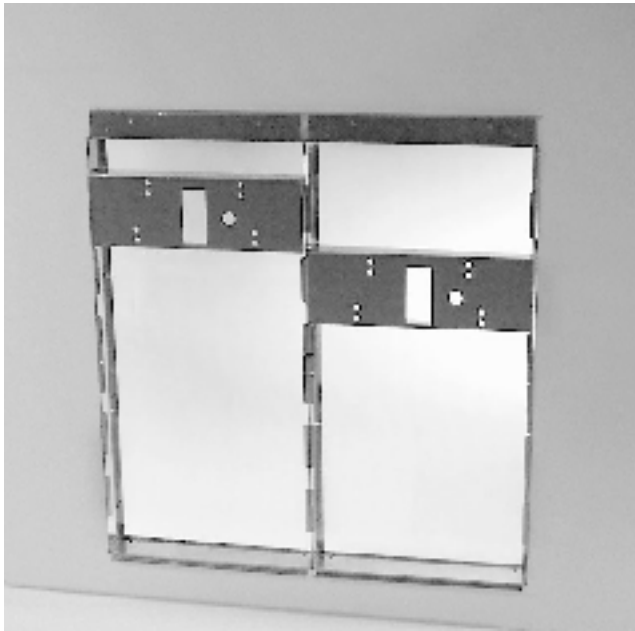

Figure 6 – HTSER-Q Rough-In

1. **Cut a rectangular wall opening** 37-1/2" (953 mm) W x 37-3/4" H (959 mm) and 4-1/2" (114 mm) above the floor line (see Figure 7). The dimensions are required to obtain proper rim and bubbler heights for compliance with ANSI standard A117.1.
2. **Reinforce the wall opening** on all sides to adequately support the water fountain. This reinforcement must support up to 150 lbs. static load and provide a means for securing the frame assembly in place.
NOTE: Building construction must allow for adequate air flow on both sides and top of remote chiller unit a minimum of 4" (102 mm) is required. See chiller installation for additional instructions.
3. **Install plumbing and electrical rough-ins.** A junction box for a (3) wire, 10 amp branch circuit is provided on the inside of the chiller. (Standard 120 Volts, 60 Hz, and single phase.)
4. **Remove frames and related hardware** from packaging. Release the two shelf rods by cutting cable ties. Attach the two frames together through the upright supports with (4) 5/16" x 3/4" (19 mm) long bolts and nuts (provided). Tighten securely.

MAKE SURE FRAME CONFIGURATION MATCHES THE COOLER TO BE INSTALLED

**REVERSED CONFIGURATION:
HIGHER UNIT ON THE RIGHT**

5/16" SCREWS OR BOLTS
(12 REQ'D-NOT FURNISHED)

5/16" HEX NUT
(4 REQ'D - PROVIDED)
P/N 111577343890

SCREWS OR BOLTS
(NOT PROVIDED)

INSTALL (3) SCREWS
(P/N 111008343890) IN FRAME
BEFORE INSTALLING IN OPENING

FRAME

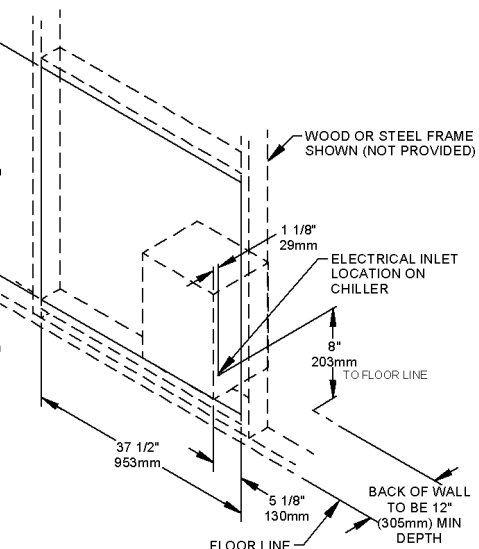

HOOK RODS (2)
P/N 101567443730

BOLT FRAMES TOGETHER
WITH 5/16" X 3/4" (19mm) BOLTS
(4 REQ'D- PROVIDED)
P/N 111577243890

**STANDARD CONFIGURATION:
HIGHER UNIT ON THE LEFT**

Figure 7 – Rough-In Assembly Dual-Station Mounting Frames

5. **Install the frame assembly squarely in wall opening** with frame upright support edges flush with the finished wall face. Secure the frame to the wall through holes with (12) 5/16" bolts or screws (not provided). Tighten securely.

NOTE: Be sure that frame is squared in location. Do not use less than required screw quantity and size.

6. **Attach the chiller shelf support rods** to the right side of the frame uprights at the second set of holes counting from the bottom and to the shelf at the (2) side holes. Line up the other shelf holes with the frame bottom holes and fasten the assembly to the wall opening using appropriately sized screws or bolts and nuts (not provided).

MODEL HT-SER SHOWN

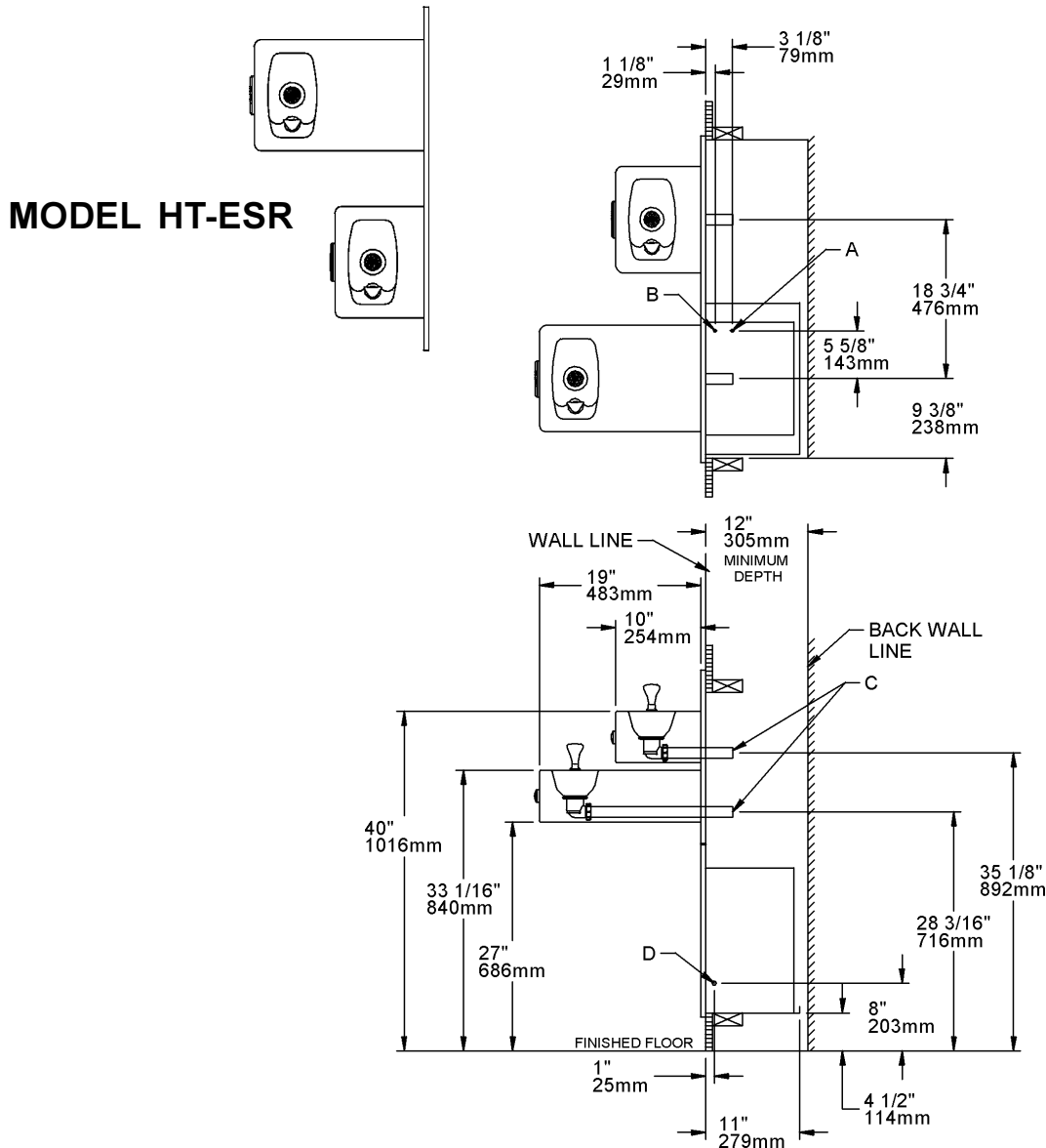

Legend

Item	Description
A	1/4" O.D. Tube - Water Outlet Connection
B	3/8" O.D. Tube - Water Inlet Connection
C	1-1/4" O.D. Waste Tube
D	Electrical Inlet on Chiller

Figure 8 - HTSER-Q Rough-In Dimensions

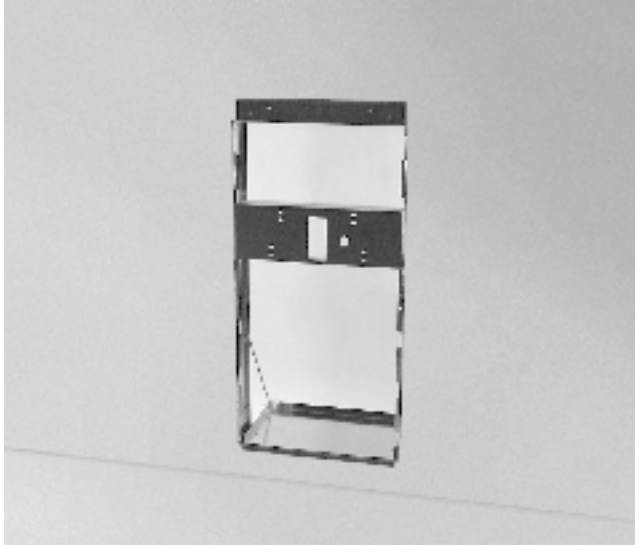

Figure 9 – HTER-Q/HTSR-Q Rough-In

1. **Cut a rectangular wall opening** 18-3/4" (475 mm) W x 37-3/4" H (959 mm) and 4-1/2" (114 mm) above the floor line (see Figure 10). The dimensions are required to obtain proper rim and bubbler heights for compliance with ANSI standard A117.1.
2. **Reinforce the wall opening** on all sides to adequately support the water fountain. This reinforcement must support up to 150 lbs. static load and provide a means for securing the frame assembly in place.
NOTE: Building construction must allow for adequate air flow on both sides and top of remote chiller unit. Minimum of 4" (102 mm) is required. See chiller installation for additional instructions.
3. **Install plumbing and electrical rough-ins.** A junction box for a (3) wire, 10 amp branch circuit is provided on the inside of the chiller. (Standard 120 Volts, 60 Hz, and single phase.)
4. **Remove frame and related hardware** from packaging. Release the two shelf rods by cutting cable ties.

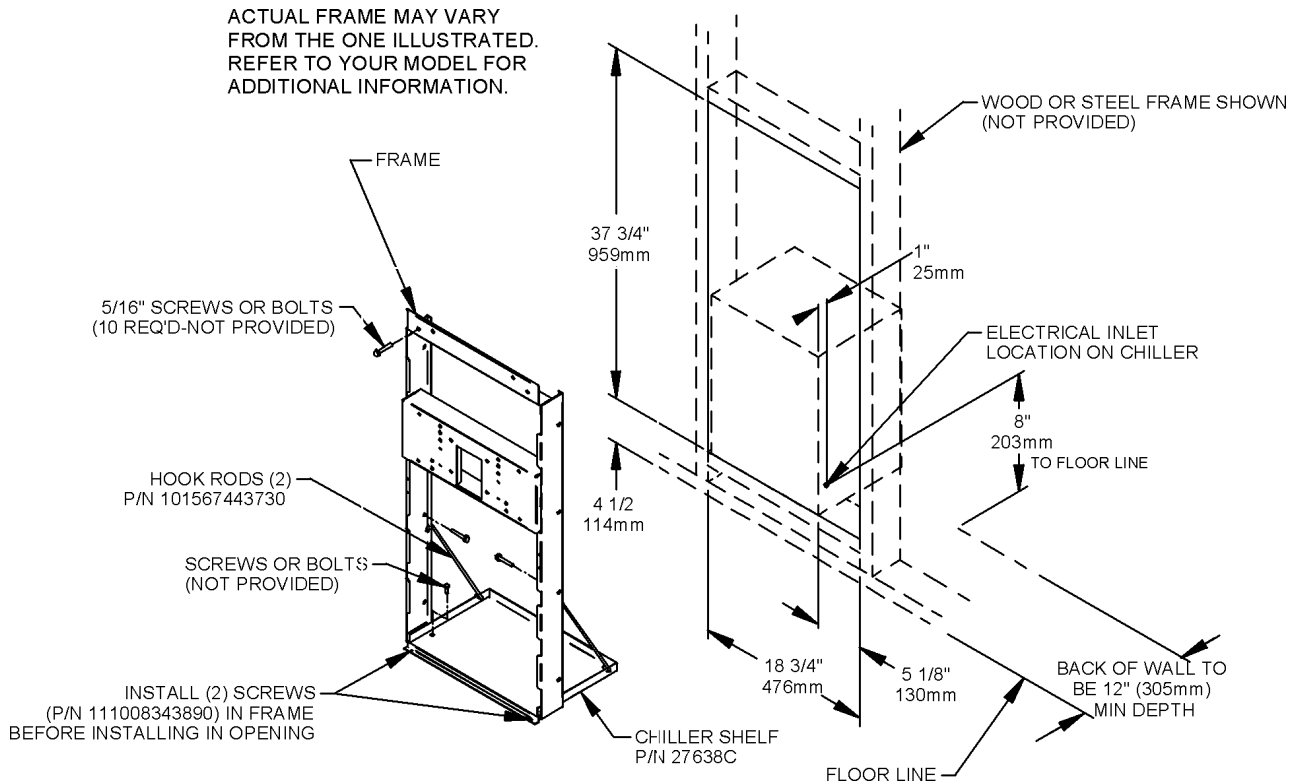
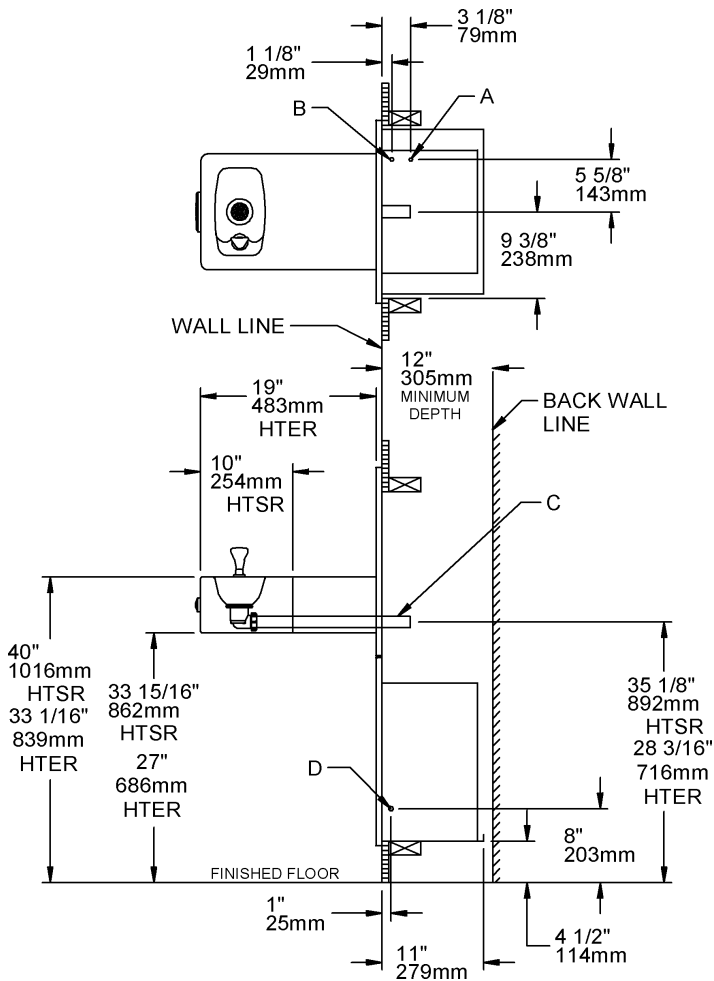

Figure 10 – Rough-In Assembly Single-Station Mounting Frames

5. **Install the frame squarely in wall** opening with frame upright edges flush with the finished wall surface. Place shelf inside frame and line up the (2) holes on each. Insert loose ends of rods into holes on sides of shelf panel. Using appropriately sized screws or bolts (not provided), fasten the shelf and frame to the bottom of wall opening. Secure the frame sides and top to the wall using (10) 5/16" bolts or screws (not provided).

NOTE: Be sure that frame is squared in location. Do not use less than the required screw quantity and size.

MODELS HT-ER/HTSR



Legend

Item	Description
A	1/4" O.D. Tube - Water Outlet Connection
B	3/8" O.D. Tube - Water Inlet Connection
C	1-1/4" O.D. Waste Tube
D	Electrical Inlet on Chiller

Figure 11 – HTER-Q/HTSR-Q Rough-In Dimensions

REQUIRED TOOLS AND MATERIALS

These tables show special tools and/or additional materials (not provided) which are necessary to complete installation of these units:

Special Tools

Item	Description	Quantity
	NONE	

Additional Materials

Item	Description	Quantity
1	Unplated copper inlet pipe	
2	Service Stop	

HTER-Q/HTSR-Q/HTSER-Q/HTESR-Q INSTALLATION

1. **Assemble and place frame in wall** as shown on preceding pages.
2. **Install chiller:** Remove front panel of chiller. **Remove and discard cardboard inner pack from between compressor and side panel.** Slide chiller onto the shelf and position it to the left within the guides on the shelf.

NOTE: Building construction must allow for adequate air flow on both sides, top and back of chiller. A minimum of 4" (102mm) on both sides and top is required. See chiller installation for additional instructions.

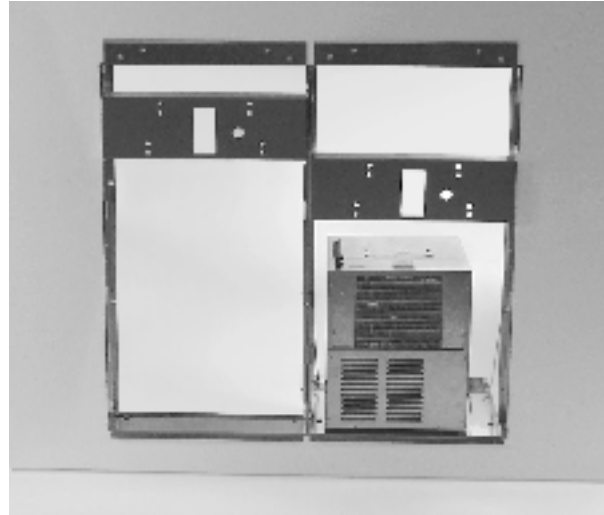

Figure 12 – Chiller Installation

3. **Make water supply connections.** Inlet port is marked on the chiller (1/4" O.D. copper tube). Bend the copper tube (provided) at an appropriate length from the chiller to opening in frame. Install the in-line strainer (provided with chiller) by pushing it in until it reaches a positive stop, approximately 3/4" (19mm) on the marked chiller inlet port. Attach an unplated and deburred copper water inlet line and a service stop (not provided) to the in-line strainer. Turn on the water supply and flush the line thoroughly. (See Fig. 5)
4. **Hang the upper panel on the mounting frame hanger.** Align holes in the panel with the holes in the mounting frame. Be sure that panel is engaged with hanger at top of frame before releasing it.

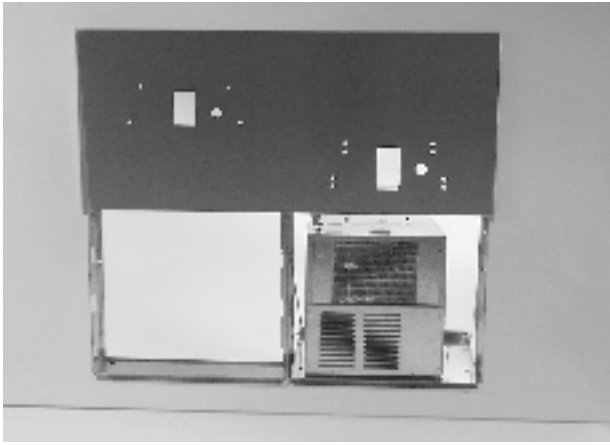

Figure 13 – Upper Panel Installation

5. **Install fountain.** Remove access cover plate on underside of fountains and SAVE the screws. Mount the fountains to the upper panel and frame with (4) 5/16" x 3/4" (19mm) long bolts and nuts provided. Tighten securely.

Note: With HTSER-Q/HTESR-Q models, the standard reach fountain must be mounted at the upper position on panel.



Figure 14 – Fountain Installation

6. **Connect the fountain drain waste tube to the building sanitary sewer system.** Connection should be made in compliance with local plumbing code requirements. (Note: Plumbing trap is not included with the fountain).
7. **Make connection between remote chiller outlet tube and fountain(s).** Outlet port is marked on the chiller (1/4" O.D. copper tube). Install a 1/4" union/tee (provided) on the marked chiller outlet port. Insert the 1/4" poly tubing coming from the fountain(s) into the union/tee. Turn on water supply and check for leaks.(See Figs. 19 or 20)



CAUTION: DO NOT SOLDER tubes while inserted into the strainer as damage to o-rings may result.

8. **These products are designed to operate on 20-105 PSIG supply line pressure.** If inlet pressure is above 105 PSIG, a pressure regulator must be installed in the supply line.



CAUTION: Any damage caused by connecting these products to a supply line with pressure lower than 20 PSIG or higher than 105 PSIG IS NOT covered under warranty.

9. **Make electrical connections to the chiller.** See chiller instructions.
10. **Check stream height from bubbler.** Stream height is factory set at 35-40 PSI. If supply pressure varies greatly from this, remove the cover bottom (Item 10 – Figure 18) and adjust the screw on the regulator (Item 32 – Figure 15). Clockwise adjustment will raise stream height and counterclockwise movement will lower stream height. For best adjustment, stream height should be approximately 1-1/2" (38mm) above the bubbler guard. (See Figure 17).
11. **Mount lower panel.** Loosen the two (2) #10-24 x 5/8" (16mm) screws at frame bottom lip. Slide upper tongue of lower panel under lower edge of already installed upper panel. Tighten previously loosened screws securely.

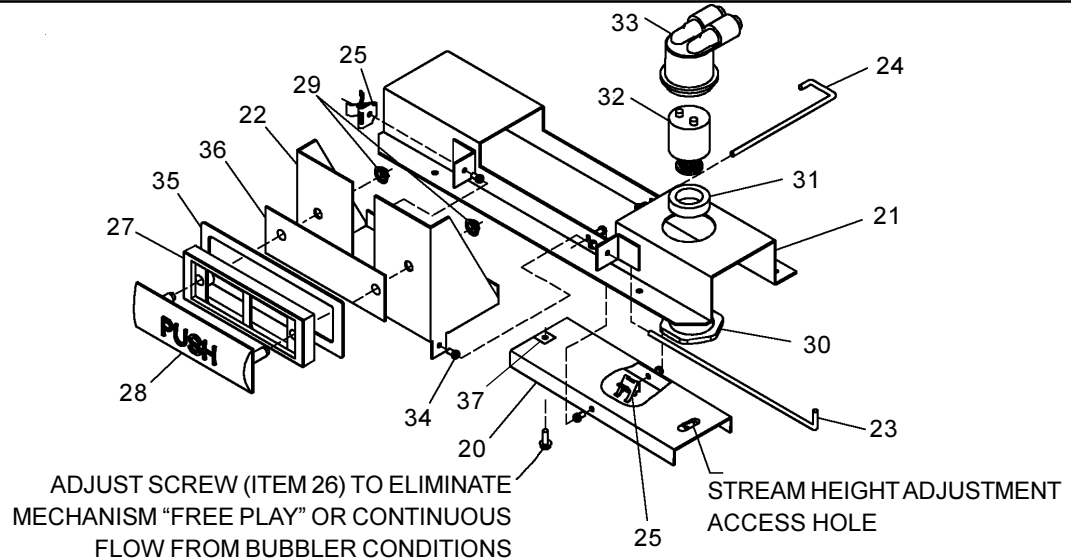

Figure 15 – Push Bar Mechanism



Figure 16 – Lower Panel Installation

12. Replace bottom access panel to fountain basin using screws provided. Tighten securely.

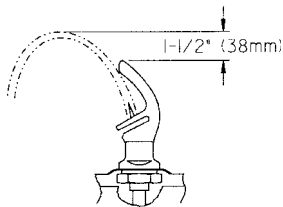

Figure 17 – Stream Height

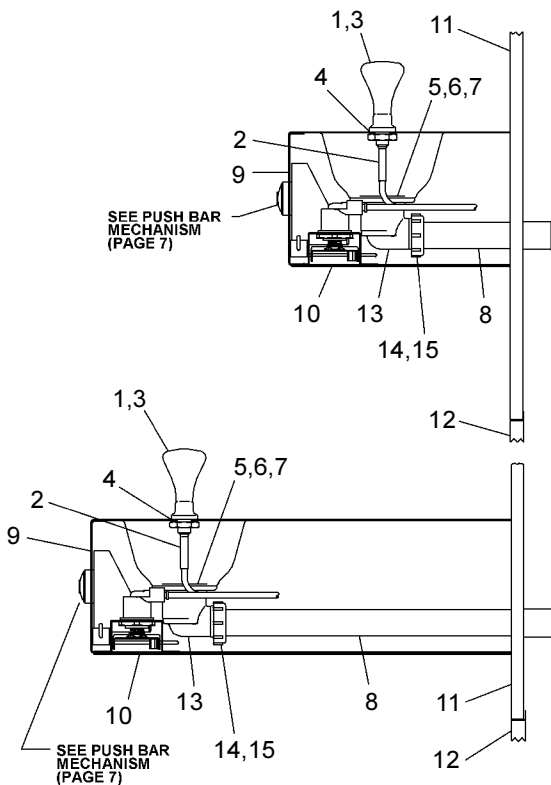

Figure 18 – Fountain Assembly - Side View

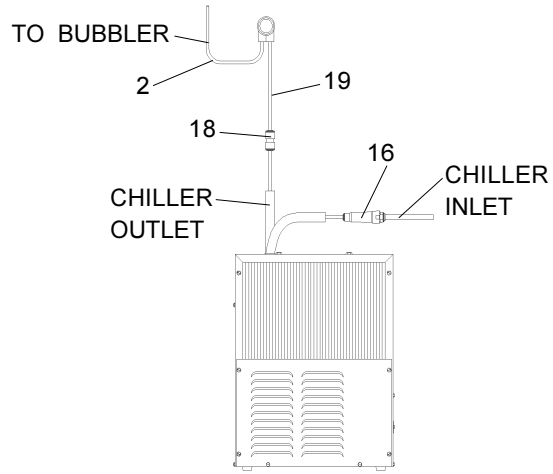

Figure 19 – HTER-Q/HTSR-Q Tube Routing

TROUBLESHOOTING & MAINTENANCE

Orifice Assembly: Mineral deposits on orifice can cause water flow to spurt or not regulate. Mineral deposits may be removed from the orifice by poking with a small round file not over 1/8" diameter, or using a small diameter wire.

CAUTION: DO NOT file or cut orifice material.

Stream Regulator: If orifice is clean, regulate flow as in Step 10 of the installation instructions. If replacement is necessary, see parts list for correct regulator part number.

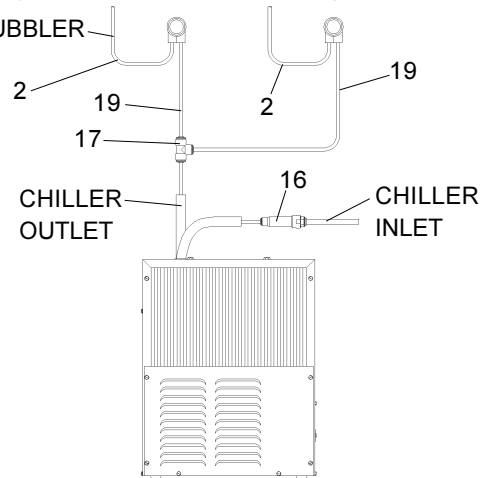
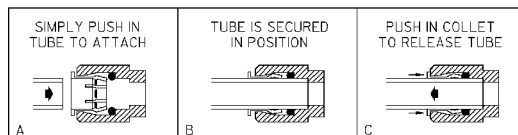

Figure 20 – HTSER-Q/HTESR-Q Tube Routing

Actuation of Quick Connect Water Fittings: Cooler is provided with lead-free connectors which utilize an o-ring water seal. To remove tubing from the fitting, relieve water pressure, push in on the gray collar while pulling on the tubing. (See Figure 21) To insert tubing, push tube straight into fitting until it reaches a positive stop (approximately 3/4").

OPERATION OF QUICK CONNECT FITTINGS



PUSHING TUBE IN BEFORE PULLING IT OUT HELPS TO RELEASE TUBE

Figure 21 – Quick Connect Fittings