

# HALSEY TAYLOR OWNERS MANUAL

USES HFC-134A REFRIGERANT

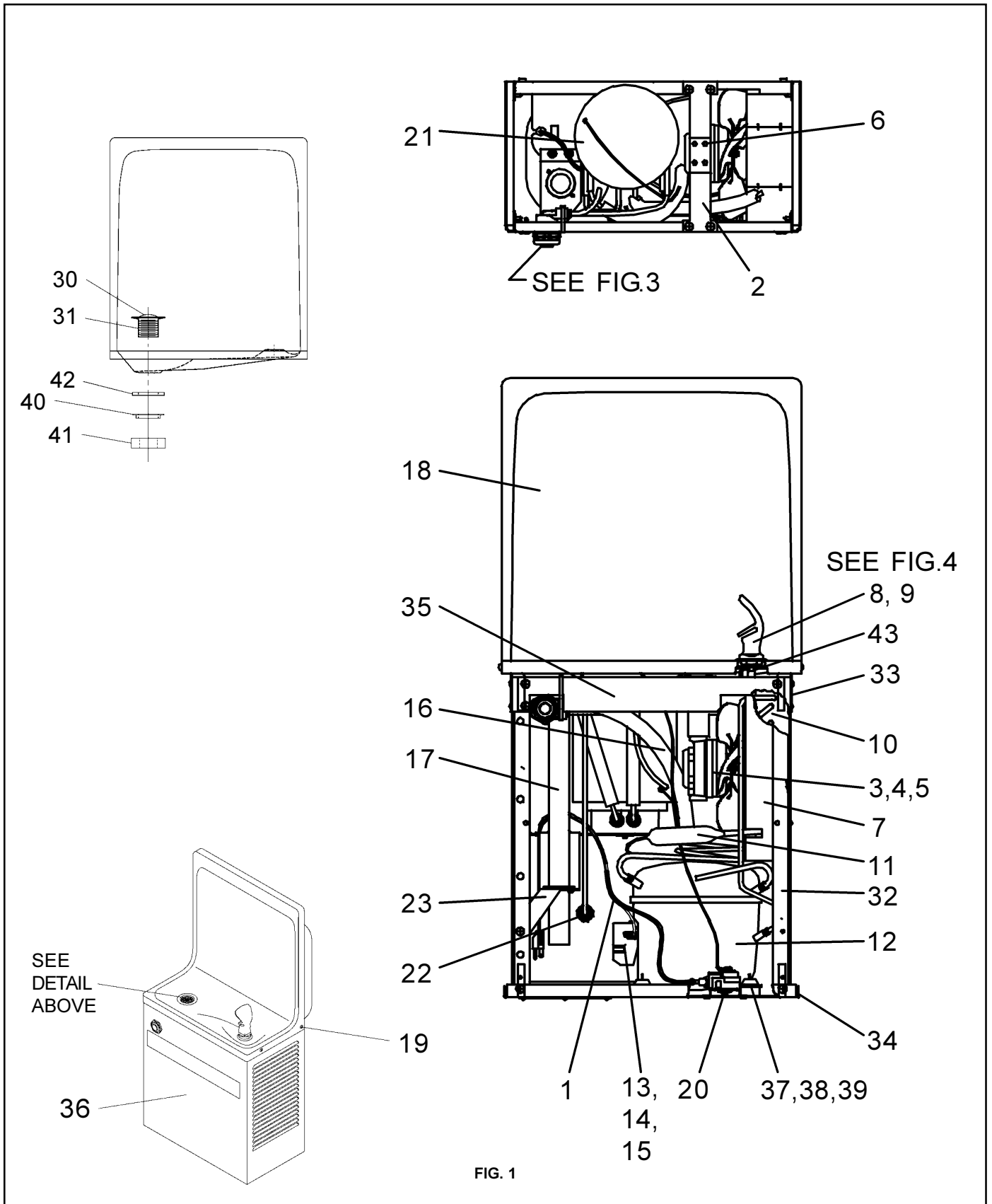

FIG. 1



**IMPORTANT**  
**ALL SERVICE TO BE PERFORMED BY AN AUTHORIZED SERVICE PERSON**

**INSTALLATION OF COOLER AND TRAP**

- 1) Hang the unit from the mounting box by placing tabs from the upper backside of the basin over top of the upper flange on mounting box as shown in FIG. 2.

**NOTE:** Mounting box and trap **MUST** be supported securely. Add fixture support carrier if wall will not provide adequate support.  
**IMPORTANT:**

- 5-1/2 in. (140mm) dimension from wall to centerline of trap must be maintained for proper fit.
- 2) Secure unit in place by positioning fastening clips as shown in FIG. 2 - Detail B.
  - 3) Install straight valve for 3/8 in. O.D. unplated copper tube.
  - 4) Remove the access panel on the underside of the cooler and set it aside.
  - 5) Connect water inlet line -- See Note 4 of General Instructions.
  - 6) Remove the slip nut and gasket from the trap and install them on the cooler waste line making sure that the end of the waste line fits into the trap. Assemble the slip nut and gasket to the trap and tighten securely.

**START UP**

Also See General Instructions

- 7) Replace the front panel and secure by retightening all screws.

Stream height is factory set at 35 PSI. If supply pressure varies greatly from this, remove items 24 and 25 and adjust screw on item 27. Clockwise adjustment will raise stream and counter-clockwise adjustment will lower stream. For best adjustment, stream should hit basin approximately 6-1/2" (165mm) from bubbler.

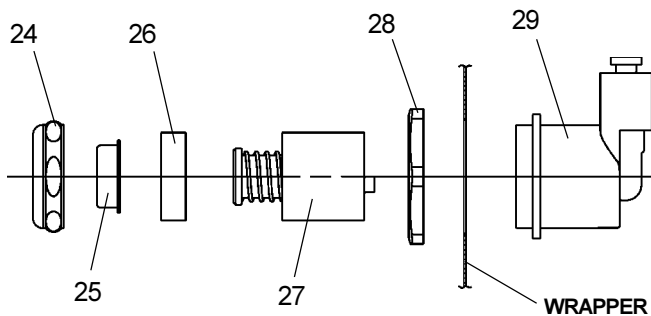
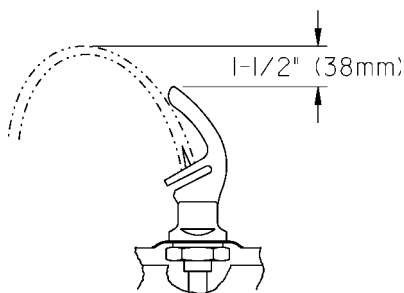

FIG. 3



CORRECT STREAM HEIGHT

FIG. 4

RWM13AQ\*1H RWM\*G-L-R

ITEMIZED PARTS LIST

ITEM NO.	PART NO.	DESCRIPTION
1	31504C	Power Cord
2	27321C	Fan Bracket
3	30699C	Fan Blade
4	70018C	Hex Nut - Fan Blade
5	31490C	Fan Motor
6	70009C	Screw (Fan Motor)
7	50186C	Shroud - Fan
8	51544C	Bubbler
9	56159C	Nipple - Bubbler
10	62152C	Condenser
11	66202C	Drier
12*	36094C	Compressor Serv. Pak EMI 70 HNR
13	36158C	Overload
14	35768C	Cover - Relay
15	35959C	Relay
16	66501C	Heat Exchanger
17	40041C	Tailpipe Assy (8 Gal)
	40429C	Precooler Assy (13 Gal)
18	27230C	Basin - Stainless Steel
19	70208C	Screw - Basin Mtg.
20	31513C	Cold Control
21	66505C	Evaporator Assembly
22	55996C	Strainer
23	27239C	Bracket - Precooler
24	40089C	Cover
25	40048C	Button
26	15005C	Retaining Nut
27	61313C	Regulator
28	40169C	Hex Nut
29	50986C	Regulator Holder
30	40038C	Strainer - Beehive
31	40619C	Ferrule - Tailpipe
32	27093C	Angle - Front Corners
33	27292C	Bracket - Basin Mounting
34	27331C	Frame - Back/Bottom
35	27094C	Bracket - Front
36	See Color Table	Wrapper
37	50144C	Grommet - Compressor Mtg.
38	70184C	Hair Pin - Cotter
39	70418C	Washer
40	40043C	Locknut
41	50105C	Tailpipe Gasket
42	50074C	Tailpipe Gasket
43	70817C	Fitting - Elbow 1/4 Stem
NS	56092C	Poly Tubing (Cut to Length)

COLOR TABLE	
PANEL COLOR	Item No. 36 Part No.
Almond Vinyl	26942C
Platinum Vinyl	26943C
Stainless Steel	26948C
Slate Vinyl	26949C

**\*INCLUDES RELAY & OVERLOAD. IF UNDER WARRANTY, REPLACE WITH SAME COMPRESSOR USED IN ORIGINAL ASSEMBLY.**

NOTE: All correspondence pertaining to any of the above water coolers or orders for repair parts MUST include Model No. and Serial No. of cooler, name and part number of replacement part.

[www.DrinkingFountainDoctor.com](http://www.DrinkingFountainDoctor.com)

800-518-5388

**Halsey Taylor**  
 2222 CAMDEN COURT  
 OAK BROOK, IL 60523  
 630.574.3500

PRINTED IN U.S.A.