

MODELS S3D, S5D, S10D and S3D-CB

S3D, S5D, S10D and S3D-CB PART LIST

REF NO.	PART NUMBER	DESCRIPTION	S3D	S3D-CB	S5D	S10D
1	10-03041-51-640	Projector*	X	X	X	X
1a	10-14884-51-550	Cartridge (7-701) (included in item 1)	X	X	X	X
2	10-03227-40-560	Projector Gasket (2 each)	X	X	X	X
3	16-06092-08-550	Projector Nipple	X	X	X	X
4	40-14731-31-550	Cold Water Line	X	X	X	X
5	40-14594-31-550	Inlet Line	X		X	X
5	40-15056-16-550	Inlet Tube		X		
6	10-14863-40-560	Waste Gasket	X	X	X	X
7	16-14848-08-550	Drain Elbow	X		X	X
7	16-15065-51-550	Drain Elbow		X		
8	17-14842-42-830	Receptor	X		X	X
8	40-14842-42-830	Receptor		X		
9	11-26275-43-890	Receptor Screws (4 each)	X	X	X	X
10	10-06876-08-640	Glass Filler Plug Button	X	X	X	X
11	60-14176-51-550	Evaporator Chiller	X	X		
11	60-14328-51-550	Evaporator Chiller			X	
11	60-14330-51-550	Evaporator Chiller				X
12	19-42339-51-550	Temperature Control	X	X	X	X
13	60-15575-51-550	Compressor Assembly	X	X		
13	60-15576-51-550	Compressor Assembly			X	
13	60-15577-51-550	Compressor Assembly				X
13a	19-14177-51-550	Relay (included in item 13)	X	X		
13a	19-14404-51-550	Relay (included in item 13)			X	
13a	19-15372-51-550	Relay (included in item 13)				X
13b	19-14178-51-550	Overload (included in item 13)	X	X		
13b	19-14846-51-550	Overload (included in item 13)			X	
13b	19-15371-51-550	Overload (included in item 13)				X
14	19-14761-51-550	Fan Motor			X	X
15	19-42095-43-730	Fan Blade			X	X
16	40-26720-43-730	Fan Bracket			X	X
17	60-14849-51-550	Condenser	X	X		
17	19-15079-51-550	Condenser			X	
17	19-15080-51-550	Condenser				X
18	10-14528-31-560	Fan Shroud	X	X	X	X
19	10-10800-51-010	Drier	X	X	X	X
20	60-14198-51-550	Capillary Tube	X	X	X	X
20	60-14356-16-550	Capillary Tube			X	
20	NO LONGER AVAILABLE	Capillary Tube				X
21	19-26681-51-550	Wiring Assembly	X	X	X	X
22	40-14866-43-960	Front Panel	X	X	X	X
23	40-14583-43-960	Left Side Panel	X	X	X	X
24	40-14584-43-960	Right Side Panel	X	X	X	X
25	11-10083-43-890	Panel Screws (36 each)	X	X	X	X
26	40-26728-43-730	Back Panel			X	X
27	40-14556-43-730	Shelf	X	X	X	X
28	40-14869-31-560	Black Toe Plate	X	X	X	X
29	11-15078-43-560	Toe Plate Screws ((2 each)	X	X	X	X
30	40-14847-43-730	Service Panel	X	X	X	X
31	73-14867-08-550	Eared Fitting (not shown)	X	X	X	X
32	13-14905-31-920	Name Plate (not shown)	X	X	X	X
33	40-14749-43-730	Base	X	X	X	X
34	16-15063-51-550	Hot Tank		X		
35	16-15058-51-550	Dispenser Assembly		X		
35a	16-06832-08-550	Gooseneck (included in item 35)		X		
35b	10-06833-31-810	Handle (included in item 35)		X		
35c	10-09673-51-550	Valve (included in item 35)		X		
36	19-15047-51-550	Hot Thermostat		X		
37	19-26109-51-550	Thermal Link		X		
38	19-15061-51-550	Wiring Harness		X		
39	60-05022-51-550	Service Valve		X		

ACCESSORIES AVAILABLE

Spanner Wrench for Bubbler - 10-03563-01-550
 Water Filtration Kit - 73-15242-51-550* (mounts external to cooler)
 73-15423-51-550* (mounts inside cooler)

XXX Please specify color when ordering. See Color Chart on page I-A for colors available.

*See Detailed Parts Section for further breakdown.

MODELS S3D, S5D, S10D and SC3D-CB

MODEL#	MFG DATE S/N ENDING	COLD* WATER CAP	COMP H/P	VOLTAGE ± 10	PH	HZ	TOTAL AMPS	R-12* REFRIG CHARGE	WATER INLET PSIG
S3D	G1 - A5	2GPH	1/10	115	1	60	2.2	2.75 oz	20-90
S5D	G1 - A5	5GPH	1/6	115	1	60	3.5	5.80 oz	20-90
S10D	G1 - A5	10GPH	1/4	115	1	60	6.1	7.50 oz	20-90
S3D-CB	G1 - A5	2GPH	1/10	115	1	60	2.2	2.75 oz	20-90
HEIGHT: 40½"			WIDTH: 12¼"			DEPTH: 12¼"			
*ARI RATINGS: Capacity at GPH cooled to 50° with 90°F ambient temperature and 80°F inlet water.									

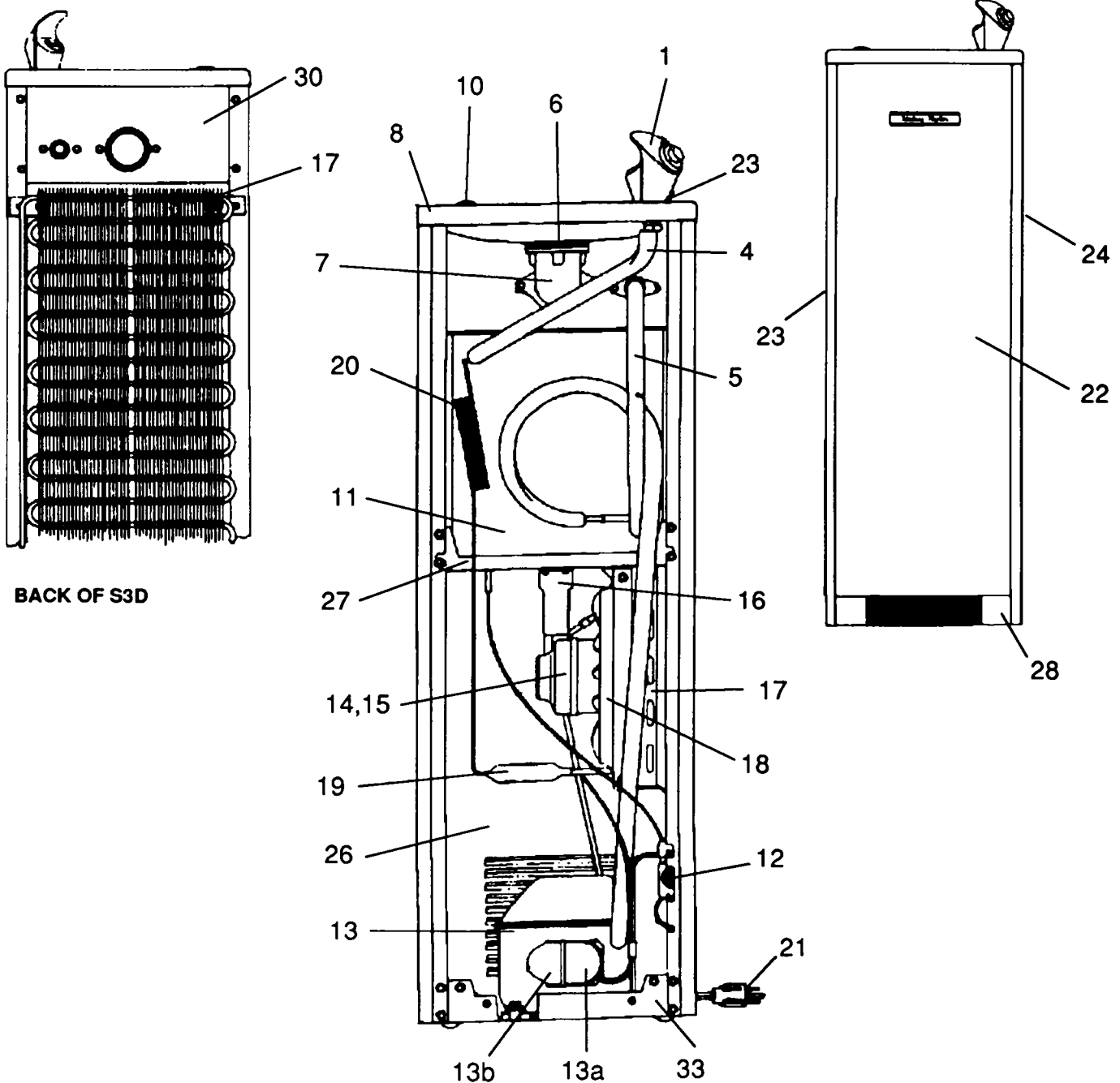

To order parts, contact your nearest Halsey Taylor wholesaler or representative.

Continued product improvement makes specifications subject to change without notice.

Halsey Taylor.