

MODELS S300-2D-1, 500-5D-1 and 1000-10D-1

S300-2D-1, 500-5D-1 and 1000-10D-1 PART LIST

REF NO.	PART NUMBER	DESCRIPTION	S300-2D-1	S500-5D-1	S1000-10D-1
1	10-03041-51-640	Projector*	X	X	X
1a	10-14884-51-550	Cartridge (7-701) (included in item 1)	X	X	X
2	10-03227-40-560	Projector Gasket (2 each)	X	X	X
3	16-42293-16--550	Projector Nipple	X	X	X
4	60-26003-51-550	Cold Water Line Assembly	X	X	X
5	40-15487-16-550	Inlet Line	X	X	X
6	10-14863-40-560	Waste Gasket	X	X	X
7	16-14848-08-550	Drain Elbow	X	X	X
8	17-14842-42-830	Receptor	X	X	X
9	11-26275-43-890	Receptor Screws (4 each)	X	X	X
10	10-06876-08-640	Glass Filler Plug Button	X	X	X
11	60-15488-51-550	Evaporator Chiller	X		
11	60-15489-51-550	Evaporator Chiller		X	
11	60-15490-51-550	Evaporator Chiller			X
12	19-42339-51-550	Temperature Control	X	X	X
13	60-26795-51-550	Compressor Assembly	X		
13	60-26797-51-550	Compressor Assembly		X	
13	60-26793-51-550	Compressor Assembly			X
13a	19-26928-82-550	Relay/Overload (included in item 13)	X		
13a	19-26922-82-550	Relay/Overload (included in item 13)		X	
13a	19-26926-82-550	Relay/Overload (included in item 13)			X
14	19-14761-51-550	Fan Motor		X	X
15	SEE NOTE**	Fan Blade		X	X
16	40-26720-43-730	Fan Bracket		X	X
17	40-14528-43-730	Shroud		X	X
18	60-26828-51-550	Condenser	X		
18	19-15079-51-550	Condenser		X	
18	19-15080-51-550	Condenser			X
19	10-10800-51-010	Drier	X	X	X
20	19-26681-51-550	Wiring Assembly	X	X	X
21	40-14866-43-XXX	Front Panel (not shown)	X	X	X
22	40-14583-43-XXX	Left Side Panel	X	X	X
23	40-14584-43-XXX	Right Side Panel	X	X	X
24	11-10083-43-890	Panel Screws (36 each) (not shown)	X	X	X
25	40-14556-43-730	Shelf	X	X	X
26	40-14749-43-730	Base	X	X	X
27	40-14869-31-560	Black Toe Plate (not shown)	X	X	X
28	11-15078-43-560	Toe Plate Screws ((2 each)	X	X	X
29	13-14905-31-920	Name Plate (not sown)	X	X	X
30	60-26806-51-550	Capillary Tube	X	X	X
30	29-26871-16-550	Capillary Tube		X	
30	29-26944-16-550	Capillary Tube			X
31	40-14847-43-730	Service Plate	X	X	X
32	40-26728-43-730	Back Panel		X	X

ACCESSORIES AVAILABLE

Spanner Wrench for Bubbler - 10-03563-01-550
 Glass Fillers – See Spec Book
 Glass Filler Kits – 73-15536-51-550 (includes 8560 Glass Filler)
 73-26095-51-550 (Does not include Glass Filler)
 Water Filtration Kit – 73-15242-51-550* (mounts external to cooler)
 73-15423-51-550* (mounts inside cooler)

XXX Please specify color when ordering. See Color Chart on page I-A for colors available.

*See Detailed Parts Section for further breakdown.

**FAN NOTE: If current fan blade screws on, use 10-42095-43-730. If it doesn't, use 10-42343-43-730.

MODELS S300-2D-1, 500-5D-1 and 1000-10D-1

MODEL#	MFG DATE S/N ENDING	COLD* WATER CAP	COMP H/P	VOLTAGE ± 10	PH	HZ	TOTAL AMPS	R-12* REFRIG CHARGE	WATER INLET PSIG
S300-2D-1	G88 - Current	2.0 GPH	1/8	115	1	60	2.2	3.25 oz	20-90
S500-5D-1	K88 - Current	5.0 GPH	1/6	115	1	60	2.9	5.6 oz	20-90
S1000-10D-1	A89 - Current	10.0 GPH	1/4	115	1	60	5.5	7.5 oz	20-90

HEIGHT: 37½"

WIDTH: 12¼"

DEPTH: 12¼"

*ARI RATINGS: Capacity at GPH cooled to 50° with 90°F ambient temperature and 80°F inlet water

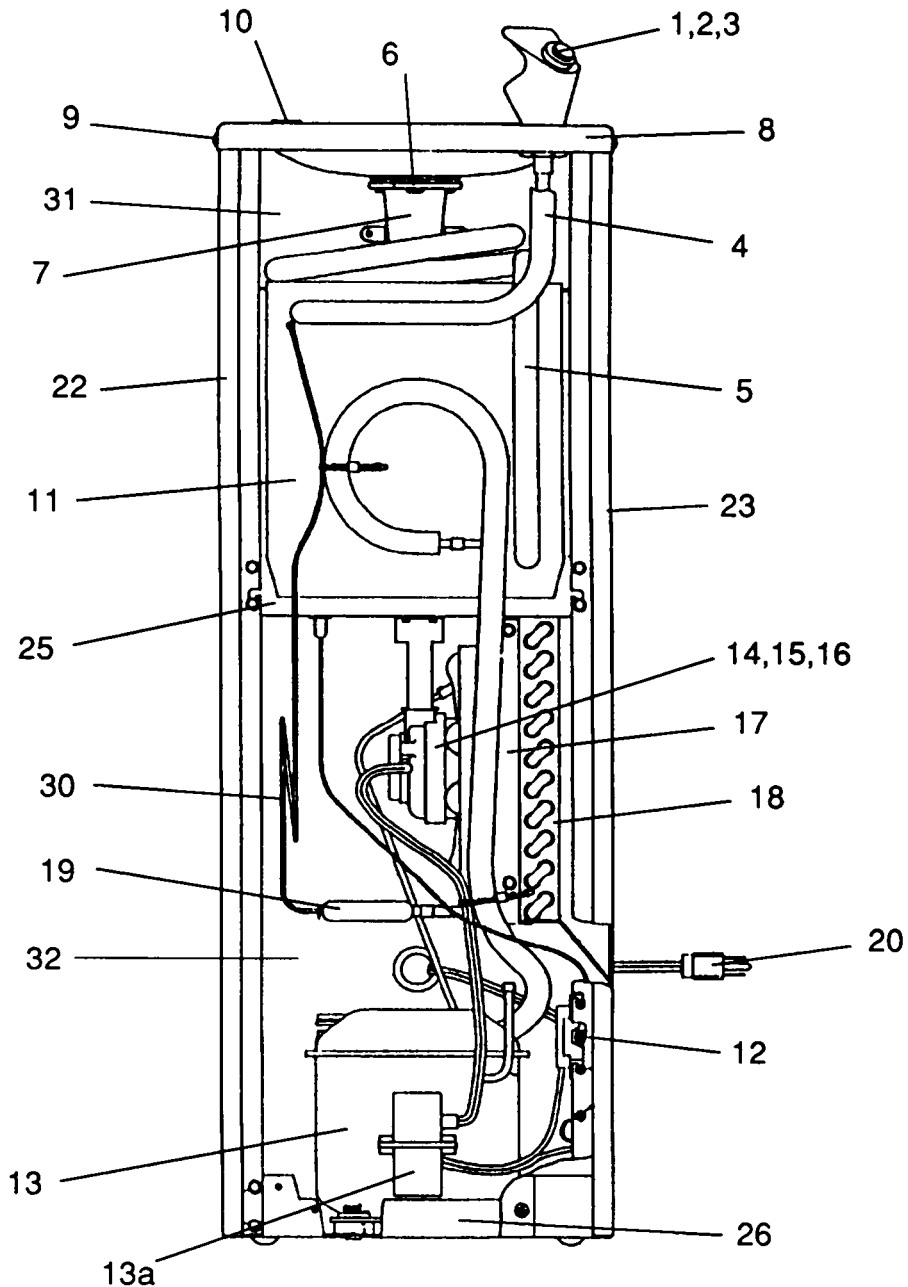

To order parts, contact your nearest Halsey Taylor wholesaler or representative.

Continued product improvement makes specifications subject to change without notice.

Halsey Taylor.