

# MODEL S300-2D-CB

## S300-2D-CB PART LIST

REF NO.	PART NUMBER	DESCRIPTION
1	10-03041-51-640	Projector*
1a	10-14884-51-550	Cartridge (7-701) (included in item 1)
2	10-03227-40-560	Projector Gasket (2 each)
3	16-42293-16-550	Projector Nipple (included in item 4)
4	60-26003-51-550	Cold Water Line Assembly
5	16-15552-51-640	Hot Water Valve Assembly*
5a	10-06833-31-810	Handle (included in item 5)
5b	16-06832-08-640	Gooseneck (included in item 5)
5c	10-09673-51-550	Stem (included in item 5)
6	40-15487-16-550	Inlet Line
7	40-15057-42-830	Receptor
8	11-26275-42-830	Receptor Screws (4 each)
9	10-14863-40-560	Waste Gasket
10	60-15065-51-550	Drain Elbow Assembly
11	60-15488-51-550	Evaporator Chiller
12	19-42339-51-550	Temperature Control
13	92523C	Hot Tank
14	19-15047-51-550	Hot Temperature Control
15	60-15575-51-550	Compressor Assembly
15a	19-14178-51-550	Overload (included in item 15)
15b	19-14177-51-550	Relay (included in item 15)
16	60-26828-51-550	Condenser
17	10-10800-51-010	Drier
18	19-26109-51-550	Thermal Link
19	19-26682-51-550	Wiring Assembly
20	60-14198-51-550	Capillary Tube
21	60-05022-51-550	Service Valve
22	40-14866-43-960	Front Panel (not shown)
23	40-14583-43-960	Left Side Panel
24	40-14584-43-960	Right Side Panel
25	11-10083-43-890	Panel Screws (27 each)
26	13-14905-31-920	Name Plate (not shown)
27	40-14556-43-730	Shelf
28	40-14749-43-730	Base
29	40-14847-43-730	Service Plate
30	40-14869-31-560	Black Toe Plate (not shown)
31	11-15078-43-560	Toe Plate Screws (2 each)

### ACCESSORIES AVAILABLE

Spanner Wrench for Bubbler - 10-03563-01-550  
 Glass Fillers: See Spec Book  
 Glass Filler Kits: 73-15536-51-550 (includes 8560 Glass Filler)  
 73-26095-51-550 (Does not include Glass Filler)

XXX Please specify color when ordering. See Color Chart on page I-A for colors available.

\*See Detailed Parts Section for further breakdown.

# MODELS S300-2D-CB

MODEL#	MFG DATE S/N ENDING	COLD* WATER CAP	COMP H/P	VOLTAGE ± 10	PH	HZ	TOTAL AMPS	R-12* REFRIG CHARGE	WATER INLET PSIG
S300-2D-CB	J5 - G88	2.0 GPH	1/10	115	1	60	8.5	2.75 oz	20-90
HEIGHT: 37½"			WIDTH: 12¼"			DEPTH: 12¼"			
*ARI RATINGS: Capacity at GPH cooled to 50° with 90°F ambient temperature and 80°F inlet water.									

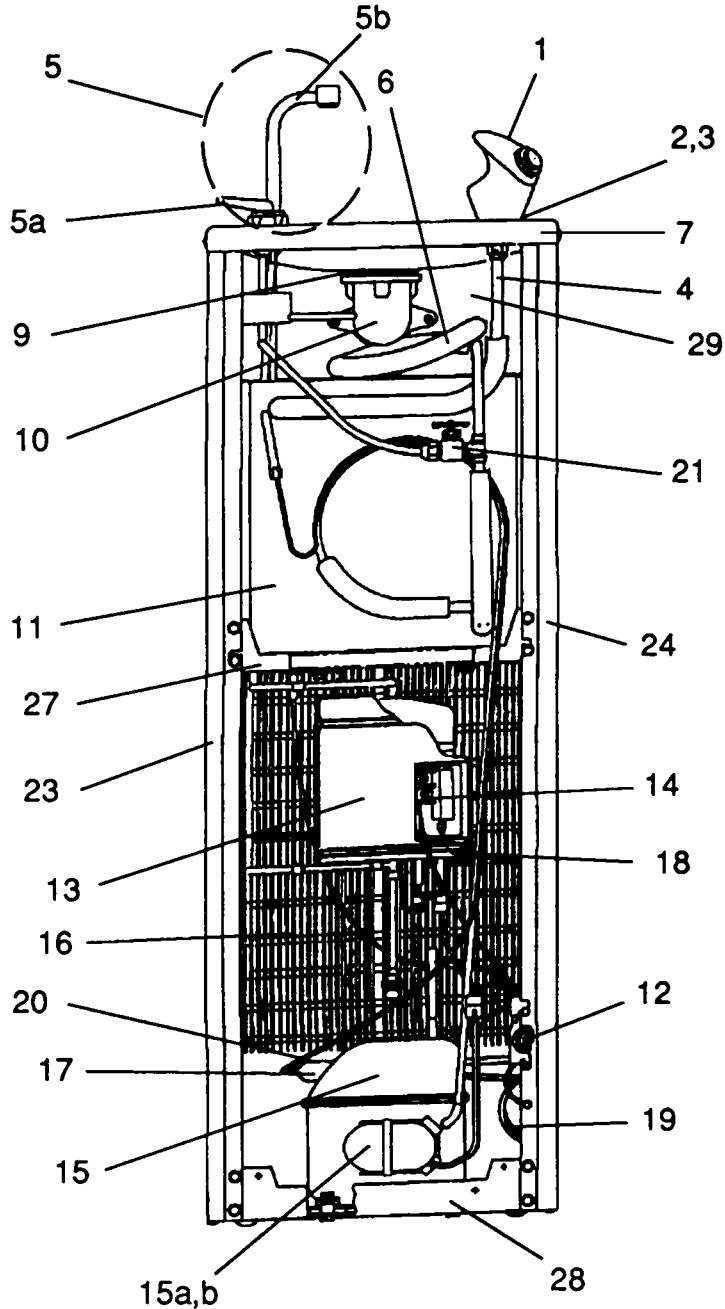

**To order parts, contact your nearest Halsey Taylor wholesaler or representative.**

*Continued product improvement makes specifications subject to change without notice.*

**Halsey Taylor.**

P.O. BOX 9001  
OAKBROOK, ILLINOIS 60521

# MODEL S300-2D-CB

## S300-2D-CB PART LIST

REF NO.	PART NUMBER	DESCRIPTION
1	10-03041-51-640	Projector*
1a	10-14884-51-550	Cartridge (7-701) (included in item 1)
2	10-03227-40-560	Projector Gasket (2 each)
3	16-06092-08--550	Projector Nipple (included in item 4)
4	60-15492--51-550	Cold Water Line Assembly
5	NO LONGER AVAILABLE	Hot Water Valve Assembly
5a	10-06833-31-810	Handle (included in item 5)
5b	16-06832-08-640	Gooseneck (included in item 5)
5c	10-09673-51-550	Stem (included in item 5)
6	40-15487-16-550	Inlet Line
7	40-15057-42-830	Receptor
8	11-26275-42-830	Receptor Screws (4 each)
9	10-14863-40-560	Waste Gasket
10	60-15065-51-550	Drain Elbow Assembly
11	60-15488-51-550	Evaporator Chiller
12	19-42339-51-550	Temperature Control
13	92523C	Hot Tank
14	19-15047-51-550	Hot Temperature Control
15	60-15575-51-550	Compressor Assembly
15a	19-14178-51-550	Overload (included in item 15)
15b	19-14177-51-550	Relay (included in item 15)
16	60-26828-51-550	Condenser
17	10-10800-51-010	Drier
18	19-26109-51-550	Thermal Link
19	19-26682-51-550	Wiring Assembly
20	60-14198-51-550	Capillary Tube
21	60-05022-51-550	Service Valve
22	40-14866-43-960	Front Panel (not shown)
23	40-14583-43-960	Left Side Panel
24	40-14584-43-960	Right Side Panel
25	11-10083-43-890	Panel Screws (27 each)
26	13-14905-31-920	Name Plate (not shown)
27	40-14556-43-730	Shelf
28	40-14749-43-730	Base
29	40-14847-43-730	Service Plate
30	40-14869-31-560	Black Toe Plate (not shown)
31	11-15078-43-560	Toe Plate Screws (2 each)

### ACCESSORIES AVAILABLE

Spanner Wrench for Bubbler - 10-03563-01-550  
Glass Fillers: See Spec Book  
Glass Filler Kits: 73-15536-51-550 (includes 8560 Glass Filler)  
73-26095-51-550 (Does not include Glass Filler)

**XXX Please specify color when ordering. See Color Chart on page I-A for colors available.**

**\*See Detailed Parts Section for further breakdown.**

# MODEL S300-2D-CB

MODEL#	MFG DATE S/N ENDING	COLD WATER CAP*	COMP HP	VOLTAGE ± 10	PH	HZ	TOTAL AMPS	R-12 REFRIG CHARGE*	WATER INLET PSIG
S3002DCB	B5 - H5	2GPH	1/10	115	1	60	8.5	2.75 oz	20-90
HEIGHT: 37½"			WIDTH: 12¼"			DEPTH: 12¼"			
*ARI ratings: capacity at GPH cooled to 50° with 90°F ambient temperature and 80°F inlet water.									

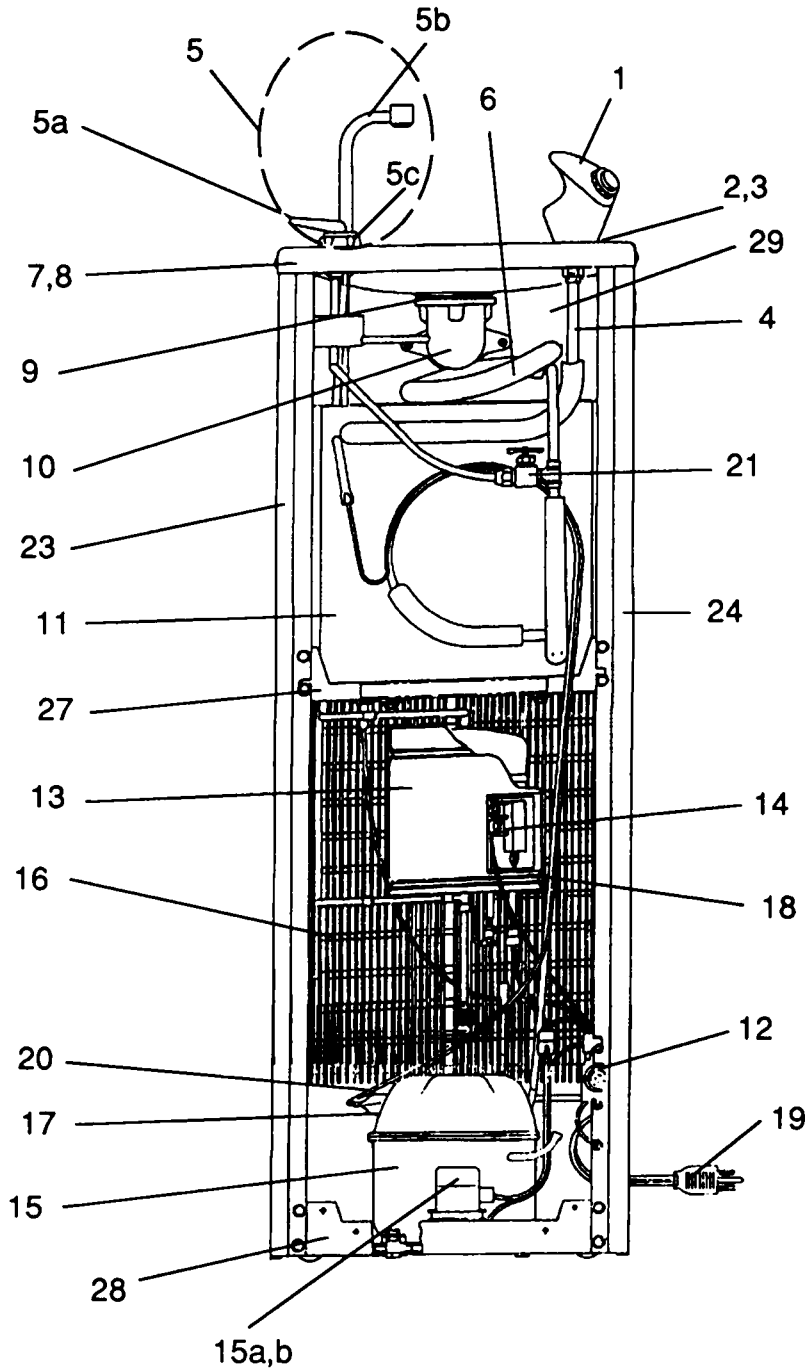

**To order parts, contact your nearest Halsey Taylor wholesaler or representative.**

*Continued product improvement makes specifications subject to change without notice.*

**Halsey Taylor.**

P.O. BOX 9001  
OAKBROOK, ILLINOIS 60521