

# MODELS SCWT14FL-2 cooler and side fountain

## SCWT14FL-2 cooler and side fountain PART LIST

REF NO.	PART NUMBER	DESCRIPTION	SCWT14-2 cooler only	SCWT14-2 side fountain
1	16-03165-08-640	Projector	X	X
2	10-03227-40-560	Projector Gasket (2 each)	X	X
3	16-42293-16-550	Projector Nipple (included in item 6)	X	
3	16-06092-08-550	Projector Nipple (included in item 6)		X
4A	60-26229-51-550	Regulator Assembly*	X	X
4B	60-14300-51-740	Valve Assembly*		X
4a	60-14549-51-550	Valve Assembly (included in item 4)*	X	
4b	60-08050-51-550	Regulator Repair Kit (for item 4a & 4B)*	X	X
4c	60-14202-51-550	Stem Assembly (included in item 4)*	X	
5	60-01166-51-640	Lever Handle Stem Assembly*		X
5a	60-08250-51-550	Lever Handle Repair Kit (for item 5)*		X
6	60-26884-51-550	Projector Supply Line	X	
6	60-08344-51-550	Projector Supply Line		X
7	60-26615-51-550	Valve to Chiller Supply Line	X	
8	60-14511-51-550	Push Button Assembly*	X	
9	10-14523-31-870	Stem Bushing	X	
10	40-26741-43-730	Lever Arm	X	
11	10-06876-08-640	Glass Filler Plug Button (not shown)	X	
12	10-26399-31-640	Drain Plug (included in item 15A)	X	
12	16-16373-08-640	Drain Plug		X
13	16-02705-08-640	Strainer Plate (included in item 15A)	X	X
14	10-01471-40-560	Waste Gasket	X	X
15A	60-27044-51-550	Precooler (includes items 12 and 13)	X	
15B	60-15732-51-550	Wasteline Assembly		X
16	10-14514-31-550	Precooler Baffle	X	
17	41-15642-08-640	Locknut		X
18	11-01158-24-740	Fiber Gasket		X
19	16-01185-08-550	Cap		X
20	60-15528-51-550	Evaporator Chiller	X	
21	19-42339-51-550	Temperature Control	X	
22	60-26793-51-550	Compressor	X	
22a	19-26926-82-550	Relay/Overload Assembly (included in 22)	X	
23	19-14761-51-550	Fan Motor	X	
24	SEE FAN NOTE**	Fan Blade**	X	
25	40-26720-43-730	Fan Bracket	X	
26	10-14528-31-560	Fan Shroud	X	
27	19-15080-51-550	Condenser	X	
28	10-10800-51-010	Drier	X	
29	19-26684-51-550	Wiring Assembly	X	
30	29-14859-51-550	Capillary Tube	X	
31	17-14037-42-590	Receptor	X	
31	17-26136-42-590	Receptor		X
32	11-26275-43-890	Receptor Screws (4 each)	X	
33	40-15074-43-XXX	Front Panel (not shown)	X	
34	40-15362-43-XXX	Right Side Panel	X	
35	40-15375-43-XXX	Left Side Panel	X	
36	11-10083-43-890	Panel Screws (40 each)	X	
37	10-14043-31-560	Black Toe Plate (not shown)	X	
38	11-15078-43-560	Toe Plate Screws (2 each)	X	
39	13-14845-31-560	Black Trim Panel (not shown)	X	
40	13-14905-31-920	Name Plate (not shown)	X	
41	40-26729-43-730	Back Panel	X	
42	40-15397-43-730	Chiller Shelf	X	
43	40-15076-43-730	Base	X	
44	10-14050-31-550	Valve Bracket	X	
45	40-07389-43-730	Cover Plate		X
46	60-15020-51-550	Drain Assembly	X	
47	40-15452-16-550	Inlet Supply Line	X	

### ACCESSORIES AVAILABLE

Glass Fillers – See Spec Book  
 Glass Filler Installation Kit – 73-26592-51-550  
 Water Filtration Kit – 73-15242-51-550\* (mounys external to cooler)  
 73-15423-51-550\* (mounts inside cooler)  
 Foot Pedal Kit – 73-14703-51-550\*  
 Vandal Proof Kit – 73-15243-51-640\*

XXX Please specify color when ordering. See Color Chart on page I-A for colors available.

\*See Detailed Parts Section for further breakdown.

\*\*FAN NOTE: If current fan screws on, use 10-42095-43-730. If it does not, use 10-42343-43-730.

# MODELS SCWT14FL-2 cooler and side fountain

MODEL#	MFG DATE S/N ENDING	COLD WATER CAP*	COMP HP	VOLTAGE ± 10	PH	HZ	TOTAL AMPS	R-12 REFRIG CHARGE*	WATER INLET PSIG
SCWT14FL-2	J88 - Current	14GPH	1/4	115	1	60	5.8	7.4 oz	20-90
COOLER:		HEIGHT: 40"	WIDTH: 16"			DEPTH: 13 1/4"			
FOUNTAIN:		HEIGHT: —	WIDTH: 10"			DEPTH: —			
*ARI Ratings: capacity at GPH cooled to 50° with 90°F ambient temperature and 80°F inlet water.									

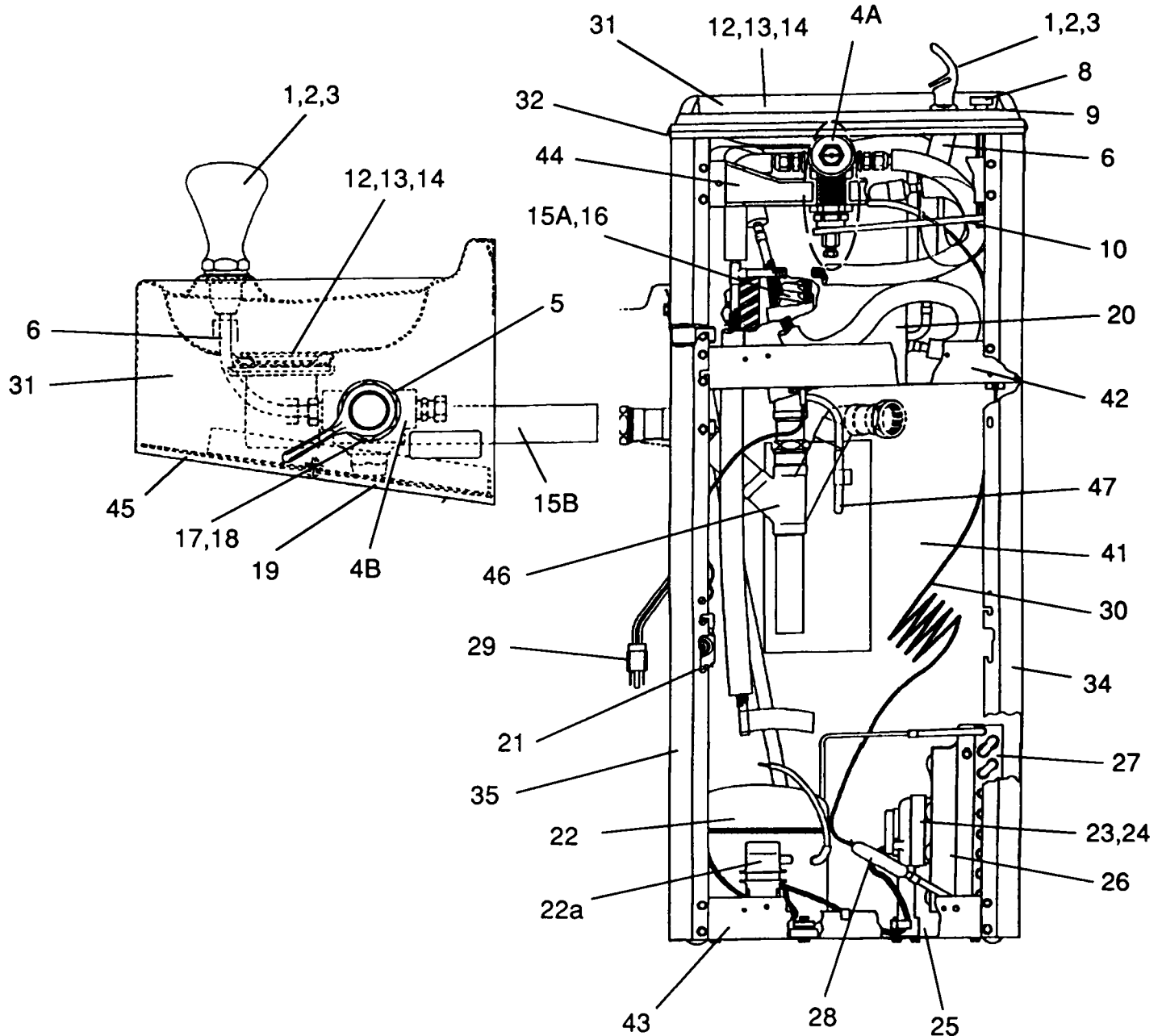

**To order parts, contact your nearest Halsey Taylor wholesaler or representative.**

*Continued product improvement makes specifications subject to change without notice.*

**Halsey Taylor.**

P.O. BOX 9001  
OAKBROOK, ILLINOIS 60521