

# MODELS SCWT4A-2, SCWT8A-2 and SCWT14A-2

## SCWT4A-2, SCWT8A-2 and SCWT14A-2 PART LIST

REF NO.	PART NUMBER	DESCRIPTION	SCWT4A-2	SCWT8A-2	SCWT14A-2
1	10-14228-31-640	Projector	X	X	X
2	10-03227-40-560	Projector Gasket (2 each)	X	X	X
3	16-42252-16-550	Projector Nipple	X	X	X
4	60-26229-51-550	Regulator Assembly*	X	X	X
4a	60-08050-51-550	Regulator Repair Kit (for item 4)*	X	X	X
4b	60-14202-51-550	Stem Assembly (included in item 4a)*	X	X	X
5	60-26332-51-550	Projector Supply Line	X	X	X
6	60-15999-51-550	Valve to Chiller Supply Line	X	X	X
7	10-14050-31-550	Valve Bracket	X	X	X
8	60-14511-51-550	Push Button Assembly*	X	X	X
9	10-14523-31-870	Stem Bushing	X	X	X
10	40-26741-43-730	Lever Arm	X	X	X
11	10-06876-08-640	Glass Filler Plug Button (not shown)	X	X	X
12	10-26399-31-640	Drain Plug (included in 15)	X	X	X
13	16-02705-08-640	Strainer Plate (included in 15)	X	X	X
14	10-01471-40-560	Waste Gasket	X	X	X
15	60-27032-51-550	Precooler Assembly (includes items 12,13)		X	X
16	60-26400-51-550	Drain Tube Assembly	X		
17	10-14514-31-550	Precooler Baffle		X	X
18	60-15488-51-550	Evaporator Chiller	X		
18	60-15489-51-550	Evaporator Chiller		X	
18	60-15528-51-550	Evaporator Chiller			X
19	19-42339-51-550	Temperature Control	X	X	X
20	60-26795-51-550	Compressor	X		
20	60-26797-51-550	Compressor		X	
20	60-26793-51-550	Compressor			X
20a	19-26928-51-550	Relay/Overload (included in 19)	X		
20a	19-26922-51-550	Relay/Overload (included in 19)		X	
20a	19-26926-82-550	Relay/Overload (included in 19)			X
21	19-14761-51-550	Fan Motor	X	X	X
22	SEE FAN NOTE**	Fan Blade**	X	X	X
23	40-26720-43-730	Fan Bracket	X	X	X
24	10-14528-31-560	Fan Shroud		X	X
25	19-15079-51-550	Condenser	X	X	
25	19-15080-51-550	Condenser			X
26	10-10800-51-010	Drier	X	X	X
27	17-14037-42-590	Receptor	X	X	X
28	11-26275-43-890	Receptor Screws (4 each)	X	X	X
29	40-15074-43-XXX	Front Panel (not shown)	X	X	X
30	40-15362-43-XXX	Right Side Panel	X	X	X
31	40-15363-43-XXX	Left Side Panel	X	X	X
32	11-10083-43-890	Panel Screws (36 each)	X	X	X
33	10-14043-31-560	Black Toe Plate (not shown)	X	X	X
34	11-15078-43-560	Toe Plate Screws (2 each)	X	X	X
35	40-15397-43-730	Chiller Shelf	X	X	X
36	40-15076-43-730	Base	X	X	X
37	13-14905-31-920	Name Plate (not shown)	X	X	X
38	40-26729-43-730	Back Panel	X	X	X
39	19-26684-51-550	Wiring Assembly	X	X	X
40	13-14845-31-560	Black Trim Panel (not shown)	X	X	X
41	29-26871-16-550	Capillary Tube	X	X	
41	29-14859-16-550	Capillary Tube			X
42	40-15452-16-550	Inlet Supply Line	X	X	X

### ACCESSORIES AVAILABLE

Glass Filler – See Spec Book

Glass Filler Installation Kit – 73-26592-51-550 (Does Not include Glass Filler)

Foot Pedal Kit – 73-14703-51-550\*

Water Filtration Kit – 73-15242-51-550\* (mounts external to cooler)

73-15423-51-550\* (mounts inside cooler)

Vandal Proof Kit – 73-15243-51-640\*

Sump Pump Kit – 73-15213-51-550

XXX Please specify color when ordering. See Color Chart on page I-A for colors available.

\*See Detailed Parts Section for further breakdown.

\*\*FAN NOTE: If current fan screws onm, use 10-42095-43-730. If it doesn't, use 10-42343-43-730.

# MODELS SCWT4A-2, SCWT8A-2 and SCWT14A-2

MODEL#	MFG DATE S/N ENDING	COLD WATER CAP*	COMP HP	VOLTAGE ± 10	PH	HZ	TOTAL AMPS	R-12 REFRIG CHARGE*	WATER INLET PSIG
SCWT4A-2	J88 -	4GPH	1/8	115	1	60	3.2	5.5 oz	20-90
SCWT8A-2	H88 -	8GPH	1/6	115	1	60	3.2	5.0 oz	20-90
SCWT14A-2	A89 -	14GPH	1/4	115	1	60	5.8	7.4 oz	20-90

HEIGHT: 40"

WIDTH: 16"

DEPTH: 13 1/4"

\*ARI Ratings: capacity at GPH cooled to 50° with 90°F ambient temperature and 80°F inlet water.

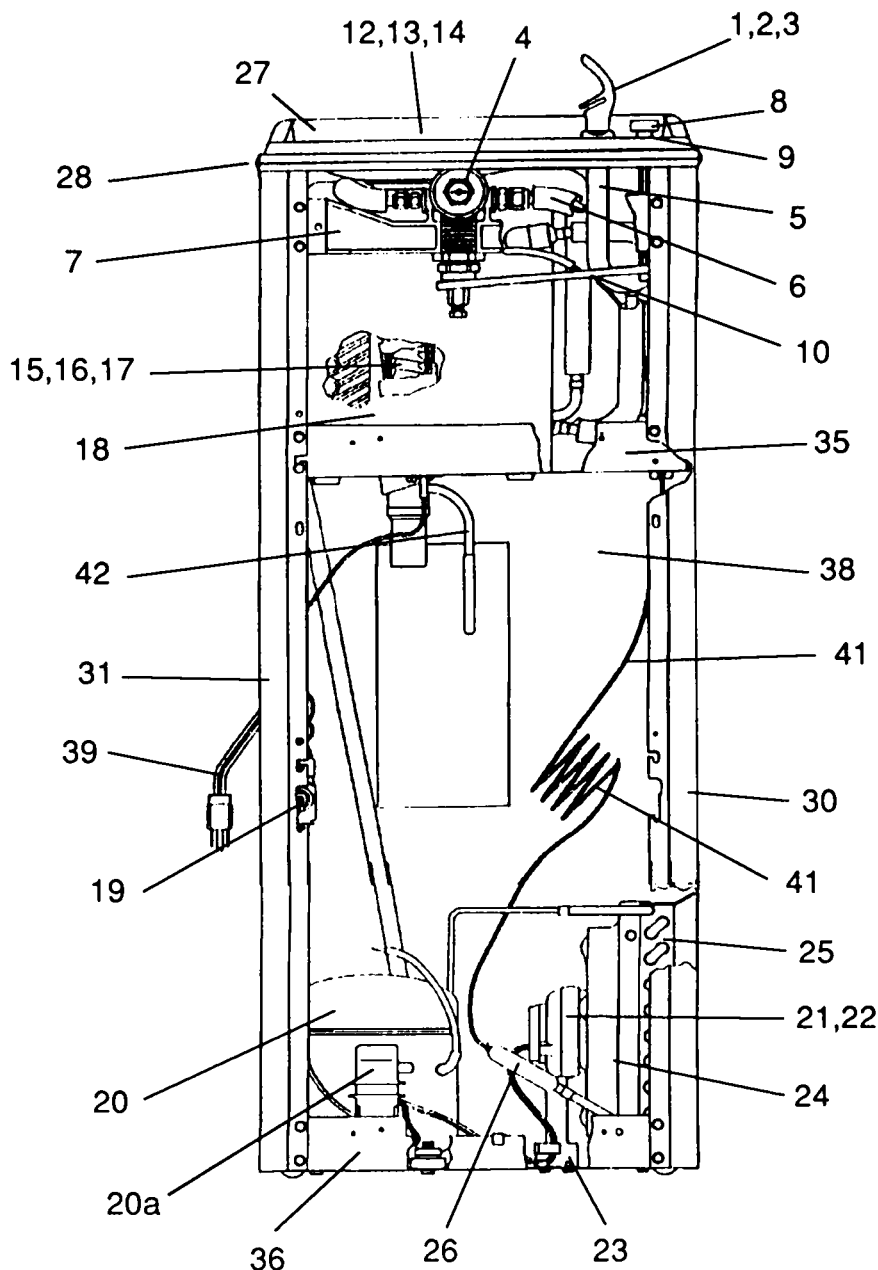

**To order parts, contact your nearest Halsey Taylor wholesaler or representative.**

*Continued product improvement makes specifications subject to change without notice.*

**Halsey Taylor.**