

MODELS SCWT4A, SCWT8A and SCWT14A

SCWT4A, SCWT8A and SCWT14A PART LIST

REF NO.	PART NUMBER	DESCRIPTION	SCWT4A	SCWT8A	SCWT14A
1	10-14228-31-640	Projector	X	X	X
2	10-03227-40-560	Projector Gasket (2 each)	X	X	X
3	10-14224-31-550	Projector Nipple	X	X	X
4	60-14800-51-550	Regulator Assembly*	X	X	X
4a	60-08050-51-550	Regulator Repair Kit (for item 4)*	X	X	X
4b	60-14202-51-550	Stem Assembly (included in item 4a)*	X	X	X
5	60-14511-51-550	Push Button Assembly*	X	X	X
6	10-14523-31-870	Stem Bushing	X	X	X
7	40-26741-43-730	Lever Arm	X	X	X
8	10-14050-31-550	Valve Bracket	X	X	X
9	10-06876-08-640	Glass Filler Plug Button (not shown)	X	X	X
10	10-26399-31-640	Drain Plug (included in 13)	X	X	X
11	16-02705-08-640	Strainer Plate (included in 13)	X	X	X
12	10-01471-40-560	Waste Gasket	X	X	X
13	60-27042-51-550	Precooler Assembly (includes items 10 & 11)		X	X
14	60-14192-51-550	Drain Tube	X		
15	10-14514-31-550	Precooler Baffle		X	X
16	60-14176-51-550	Evaporator Chiller	X		
16	60-14328-51-550	Evaporator Chiller		X	
16	60-15038-51-550	Evaporator Chiller			X
17	19-42339-51-550	Temperature Control	X	X	X
18	10-10800-51-010	Drier	X	X	X
19	60-15575-51-550	Compressor	X		
19	60-15572-51-550	Compressor		X	
19	60-15573-51-550	Compressor			X
19a	19-14177-51-550	Relay (included in 19)	X		
19a	19-14891-51-550	Relay (included in 19)		X	
19a	19-14062-51-550	Relay (included in 19)			X
19b	19-14178-51-550	Overload (included in 19)	X		
19b	19-14894-51-550	Overload (included in 19)		X	
19b	19-14061-51-550	Overload (included in 19)			X
20	19-14761-51-550	Fan Motor	X	X	X
21	SEE FAN NOTE**	Fan Blade**	X	X	X
22	40-26720-43-730	Fan Bracket	X	X	X
23	10-14528-31-560	Fan Shroud		X	X
24	19-15079-51-550	Condenser	X	X	
24	19-15080-51-550	Condenser			X
25	17-14037-42-590	Receptor	X	X	X
26	11-26275-43-890	Receptor Screws (4 each)	X	X	X
27	40-15073-43-XXX	Front Panel (not shown)	X	X	X
28	40-15363-43-XXX	Right Side Panel	X	X	X
29	40-15362-43-XXX	Left Side Panel	X	X	X
30	11-10083-43-890	Panel Screws (36 each)	X	X	X
31	13-14905-31-920	Name Plate (not shown)	X	X	X
32	13-14845-31-560	Black Trim Panel (not shown)	X	X	X
33	10-14043-31-560	Black Toe Plate (not shown)	X	X	X
34	40-15076-43-730	Base	X	X	X
35	40-15397-43-730	Chiller Shelf	X	X	X
36	11-15078-43-560	Toe Plate Screw (2 each)	X	X	X
37	19-26684-51-550	Wiring Assembly	X	X	X
38	40-26729-43-730	Back Panel	X	X	X
39	29-15163-16-550	Capillary Tube	X	X	X

ACCESSORIES AVAILABLE

Glass Fillers – See Spec Book

Glass Filler Installation Kit – 73-15238-51-550

Water Filtration Kit – 73-15242-51-550* (mounts external to cooler)

73-15423-51-550* (mounts inside cooler)

Vandal Proof Kit – 73-15243-51-640*

Foot Pedal Kit – 73-14703-51-550*

Sump Pump Kit – 73-15213-51-550

XXX Please specify color when ordering. See Color Chart on page I-A for colors available.

*See Detailed Parts Section for further breakdown.

**FAN NOTE: If current fan blade screws on, use 10-42095-43-730. If it doesn't, use a 10-42343-43-730.

MODELS SCWT4A, SCWT8A and SCWT14A

MODEL#	MFG DATE S/N ENDING	COLD WATER CAP*	COMP HP	VOLTAGE ± 10	PH	HZ	TOTAL AMPS	R-12 REFRIG CHARGE*	WATER INLET PSIG
SCWT4A	A88 and older	4GPH	1/10	115	1	60	2.9	5.75 oz	20-90
SCWT8A	A88 and older	8GPH	1/8	115	1	60	3.2	7.00 oz	20-90
SCWT14A	A88 and older	14GPH	1/5	115	1	60	4.9	7.25 oz	20-90

HEIGHT: 40"

WIDTH: 16"

DEPTH: 13¼"

*ARI Ratings: capacity at GPH cooled to 50° with 90°F ambient temperature and 80°F inlet water.

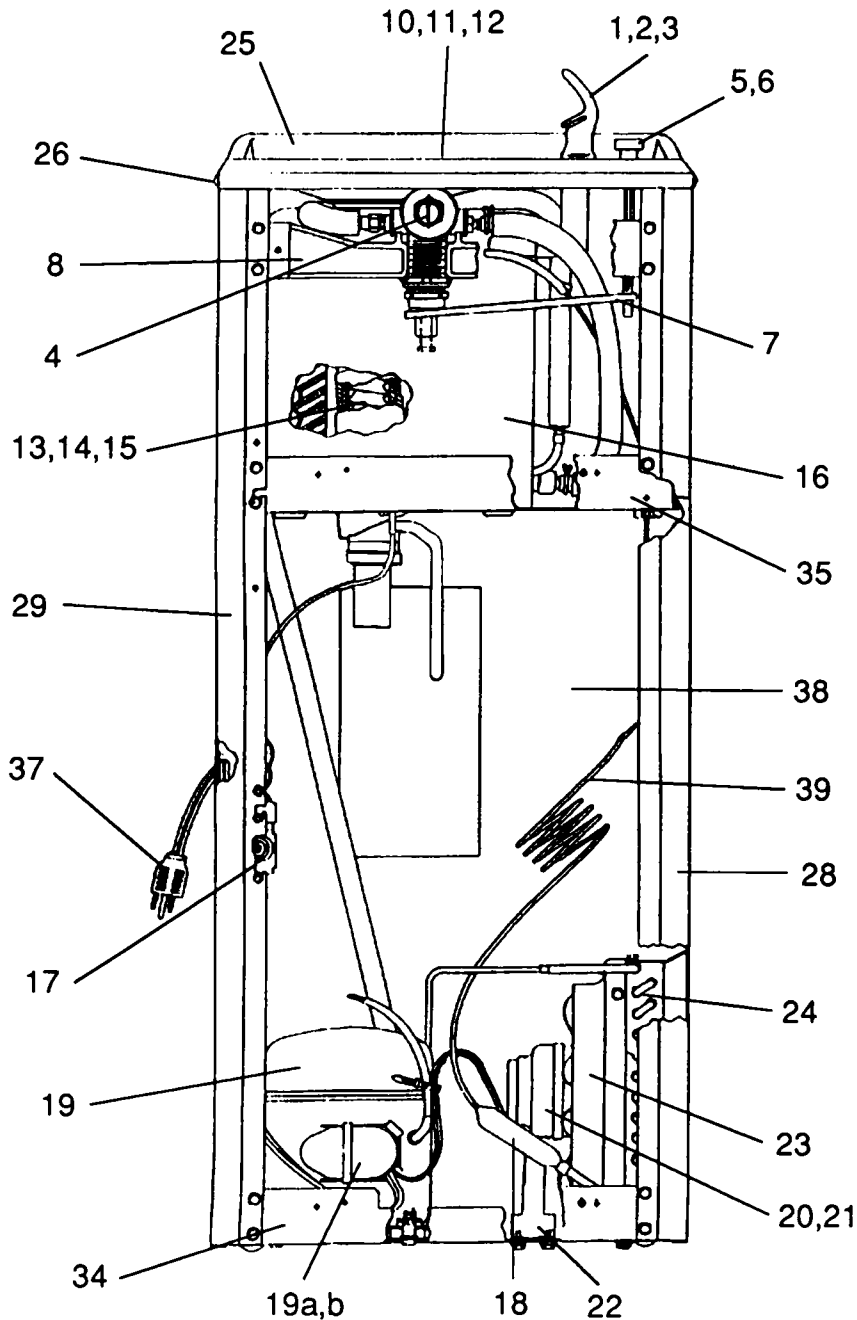

To order parts, contact your nearest Halsey Taylor wholesaler or representative.

Continued product improvement makes specifications subject to change without notice.

Halsey Taylor.