

MODELS SCWT8A-1CB and SCWT14A-1CB

SCWT8A-1CB and SCWT14A-1CB PART LIST

REF NO.	PART NUMBER	DESCRIPTION	SCWT8A-1CB	SCWT14A-1CB
1	10-14228-31-640	Projector	X	X
2	10-03227-40-560	Projector Gasket (2 each)	X	X
3	16-42252-16-550	Projector Nipple (included in item 8)	X	X
4	60-26229-51-550	Regulator Assembly*	X	X
4a	60-14549-51-550	Valve Assembly (included in item 4)*	X	X
4b	60-08050-51-550	Regulator Repair Kit (for item 4)*	X	X
4c	60-14202-51-550	Stem Assembly (included in item 4A)*	X	X
5	60-14511-51-550	Push Button Assembly*	X	X
6	10-14523-31-870	Stem Bushing	X	X
7	40-26741-43-730	Lever Arm	X	X
8	60-26332-51-550	Projector Supply Line	X	X
9	60-15999-51-550	Valve to Chiller Supply Line	X	X
10	10-14050-31-550	Valve Bracket	X	X
11	16-14306-51-640	Hot Water Valve Assembly*	X	X
11a	10-06833-31-810	Handle (included in item 11)	X	X
11b	10-06832-08-640	Gooseneck (included in item 11)	X	X
11c	10-09673-51-550	Stem (included in item 11)	X	X
12	10-26399-31-640	Drain Plug	X	X
13	16-02705-08-640	Strainer Plate	X	X
14	10-01471-40-560	Waste Gasket	X	X
15	60-26653-51-550	Precooler Assembly	X	X
16	10-14514-31-550	Precooler Baffle	X	X
17	60-26739-51-550	Condenser Waste Line	X	X
18	60-15489-51-550	Evaporator Chiller	X	
18	60-15528-51-550	Evaporator Chiller		X
19	19-42339-51-550	Temperature Control	X	X
20	92521C	Hot Tank	X	X
21	19-15047-51-550	Hot Temperature Control	X	X
22	60-15572-51-550	Compressor	X	
22	60-15573-51-550	Compressor		X
22a	19-14891-51-550	Relay (included in 22)	X	
22a	19-14062-51-550	Relay (included in 22)		X
22b	19-14894-51-550	Overload (included in 22)	X	
22b	19-14061-51-550	Overload (included in 22)		X
23	19-14761-51-550	Fan Motor	X	X
24	SEE FAN NOTE**	Fan Blade**	X	X
25	40-26720-43-730	Fan Bracket	X	X
26	10-14528-31-560	Fan Shroud	X	X
27	19-15079-51-550	Condenser	X	
27	19-15080-51-550	Condenser		X
28	10-10800-51-010	Drier	X	X
29	29-14356-16-550	Capillary Tube	X	
29	29-14568-16-550	Capillary Tube		X
30	16-15464-08-550	Service Valve	X	X
31	19-26685-51-550	Wiring Assembly	X	X
32	19-26109-51-550	Thermal Link	X	X
33	40-15018-42-590	Receptor	X	X
34	11-26275-43-890	Receptor Screws (4 each)	X	X
35	40-15074-43-XXX	Front Panel (not shown)	X	X
36	40-15362-43-XXX	Right Side Panel	X	X
37	40-15363-43-XXX	Left Side Panel	X	X
38	11-10083-43-890	Panel Screws (40 each)	X	X
39	10-14043-31-560	Black Toe Plate (not shown)	X	X
40	11-15078-43-560	Toe Plate Screws (2 each)	X	X
41	40-15397-43-730	Chiller Shelf	X	X
42	40-15076-43-730	Base	X	X
43	13-14905-31-920	Name Plate (not shown)	X	X
44	40-26729-43-730	Back Panel	X	X
45	13-14845-31-560	Black Trim Panel (not shown)	X	X

ACCESSORIES AVAILABLE

Foot Pedal Kit* - 73-14703-51-550
 Sump Pump Kit - 73-15213-51-550
 Vandal Proof Kit - 73-15243-51-640*

XXX Please specify color when ordering. See Color Chart on page I-A for colors available.

*See Detailed Parts Section for further breakdown.

FAN NOTE: If current fan screws on, use 10-42095-43-730. If it doesn't, use 10-42343-43-730.

MODELS SCWT8A-1CB and SCWT14A-1CB

MODEL#	MFG DATE S/N ENDING	COLD WATER CAP*	COMP HP	VOLTAGE ± 10	PH	HZ	TOTAL AMPS	R-12 REFRIG CHARGE*	WATER INLET PSIG
SCWT8A-1CB	A88 - H88	8GPH	1/8	115	1	60	9.5	7.00 oz	20-90
SCWT14A-1CB	A88 - H88	14GPH	1/5	115	1	60	11.3	7.25 oz	20-90
HEIGHT: 40"			WIDTH: 16"			DEPTH: 13 1/4"			
*ARI Ratings: capacity at GPH cooled to 50° with 90°F ambient temperature and 80°F inlet water.									

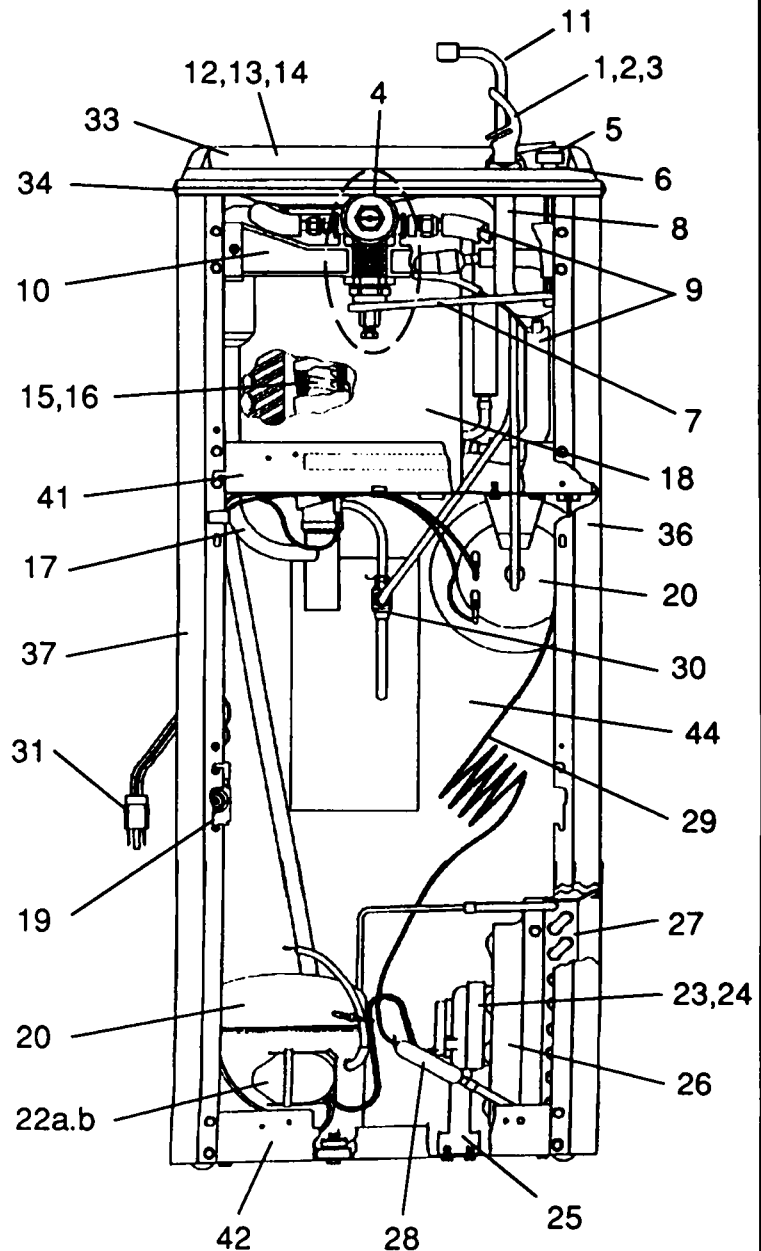
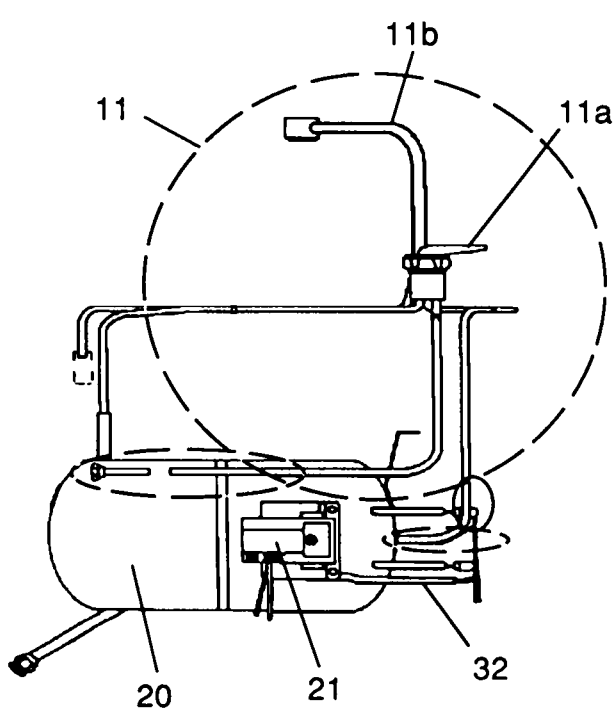

To order parts, contact your nearest Halsey Taylor wholesaler or representative.

Continued product improvement makes specifications subject to change without notice.

Halsey Taylor.