

HALSEY TAYLOR OWNERS MANUAL

USES HFC-134A REFRIGERANT

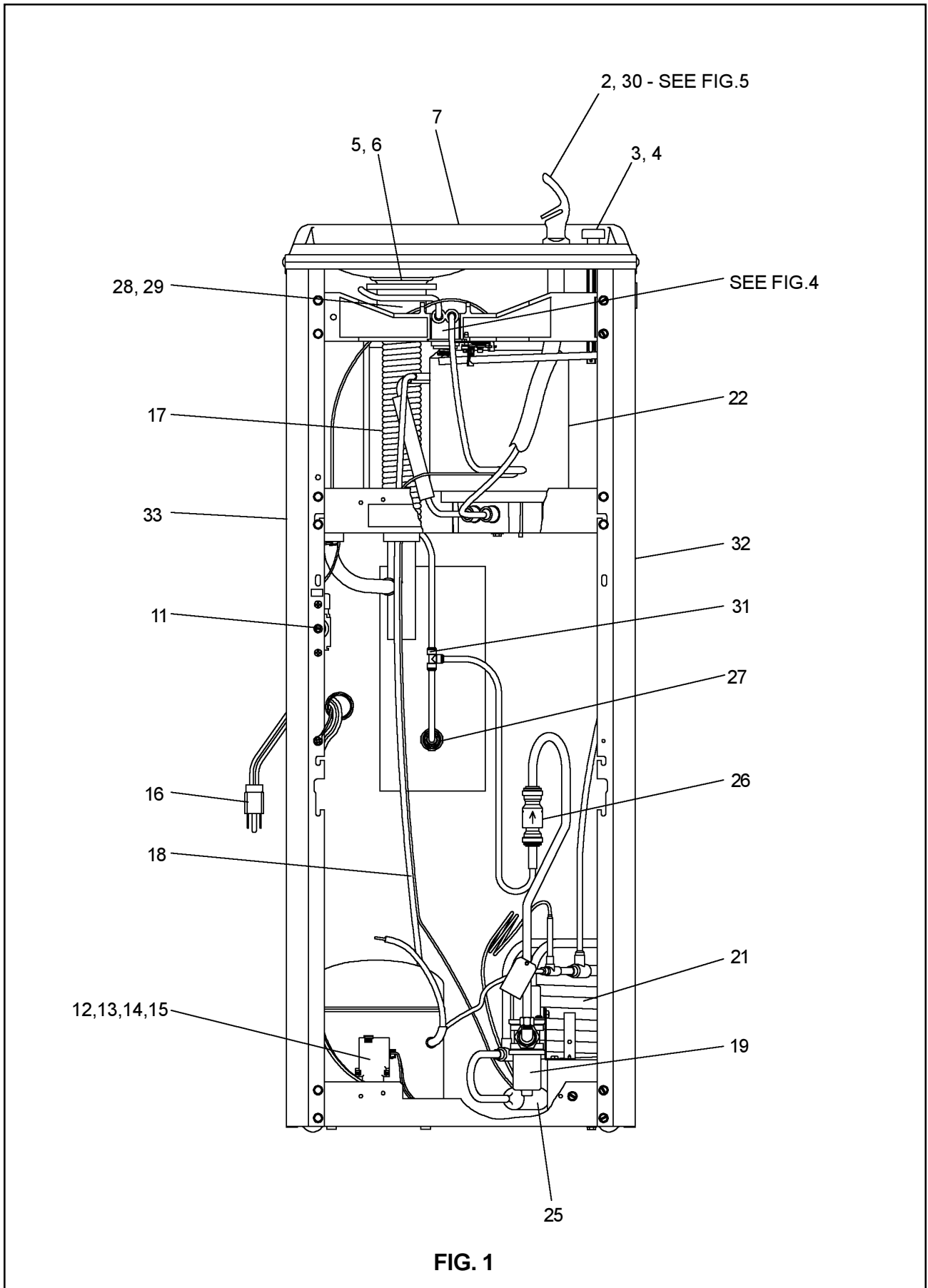

FIG. 1

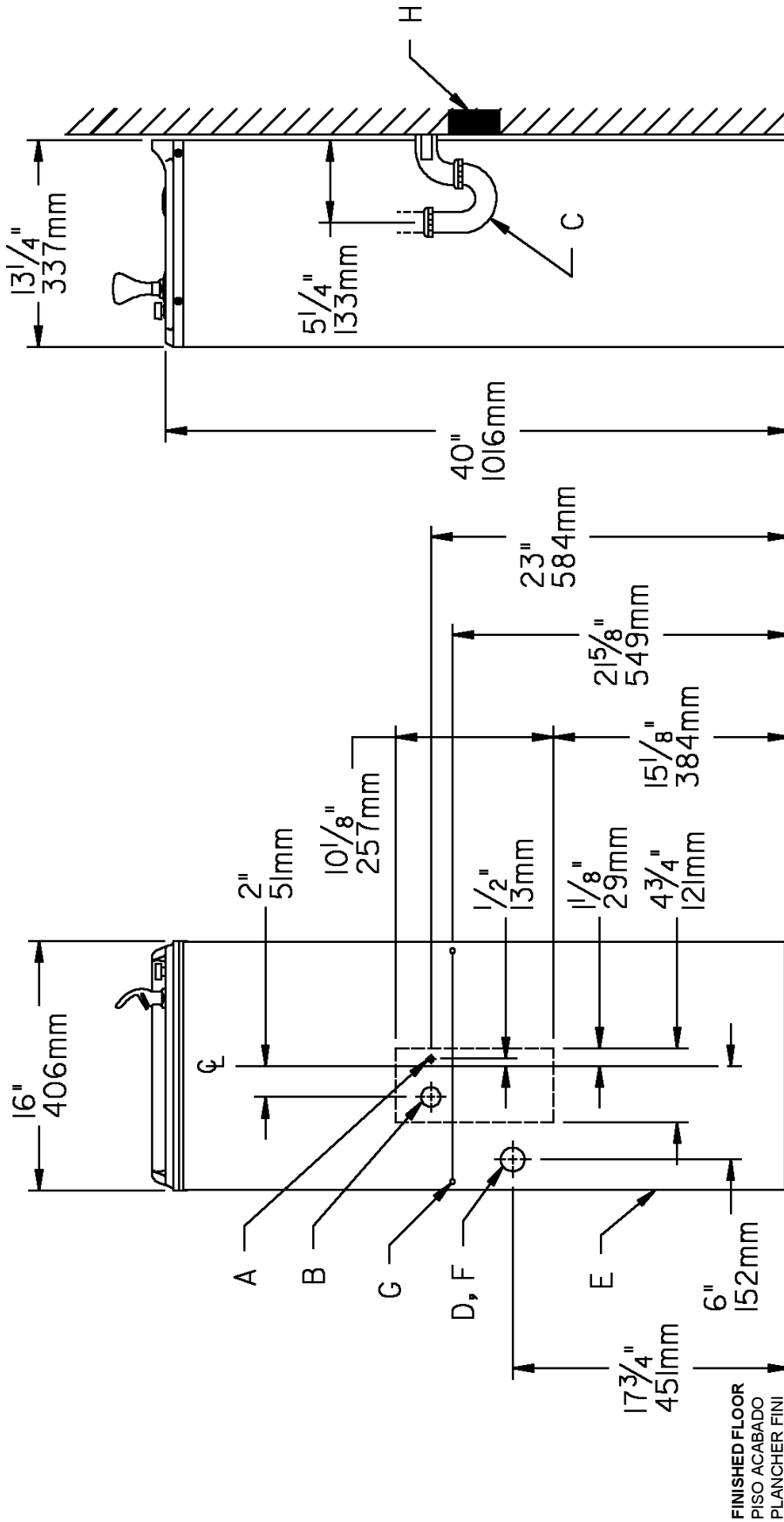

FIG. 2

- LEGEND/LEYENDA/LÉGENDE**
- A = RECOMMENDED WATER SUPPLY LOCATION 3/8 O.D. UNPLATED COPPER TUBE CONNECT STUB OUT 1-1/2 IN. (38mm)**
 SE RECOMIENDA UBICAR EL TUBO CORTO DE CONEXIÓN AL TUBO DE COBRE SIN CHAPAR DE 3/8" DE DIÁM. EXT. A 1-1/2" (38 mm) FUERA DE LA LLAVE DE PASO EN LA PARED COLOCADA POR TERCEROS.
 EMPLACEMENT RECOMMANDÉ D'ALIMENTATION EN L'EAU PAR TUBE EN CUIVRE NON PLAQUÉ DE 3/8 PO. (9.5 mm) D.E. CONNECTANT UNE TUYAUTERIE DE 1-1/2 PO. (38 mm) DEPUIS LE ROBINET D'ARRÊT FOURNI PAR D'AUTRES.
 - B = RECOMMENDED LOCATION FOR WASTE OUTLET 1-1/4" O.D. DRAIN**
 UBICACIÓN RECOMENDADA PARA EL DRENAJE DE SALIDA DE AGUA, DE 1 1/4" DE DIÁMETRO.
 EMPLACEMENT RECOMMANDÉ POUR LE DRAIN DE D.E. 1-1/4" DE SORTIE D'EAU.
 - C = 1-1/4" TRAP NOT FURNISHED**
 PURGADOR DE 1 1/4" NO PROPORCIONADO
 SIPHON 1-1/4" NON FOURNI
 - D = ELECTRICAL OUTLET LOCATION**
 UBICACIÓN DE LA TOMA DE ELECTRICIDAD
 EMPLACEMENT DE LA PRISE DE COURANT
 - E = INSURE PROPER VENTILATION BY MAINTAINING 4" (102mm) (MIN.) CLEARANCE FROM CABINET LOUVERS TO WALL.**
 ASEGURE UNA VENTILACIÓN ADECUADA MANTENIENDO UN ESPACIO E 4" (102mm) (MIN.) DE HOLGURA ENTRE LA REJILLA DE VENTILACIÓN DEL MUEBLE Y LA PARED.
 ASSUREZ-VOUS UNE BONNE VENTILATION EN GARDANT 4" (102mm) (MIN.) ENTRE LES ÉVÉNENTS DE L'ENCEINTE ET LE MUR.
 - F = POWER CORD 4' (1219mm) LONG**
 CABLE ELÉCTRICO DE 4' (1219mm) PIE DE LARGO
 CORDON D'ALIMENTATION 4' (1219mm)
 - G = WALL SCREW HOLES**
 AGUJEROS DE TORNILLOS DE PARED
 TROUS DE VIS DU MUR
 - H = 2 X 4 BLOCKING**
 BLOQUEO DE 2 X 4
 BLOC 2 X 4

PUSH BUTTON VALVE ADJUSTMENT

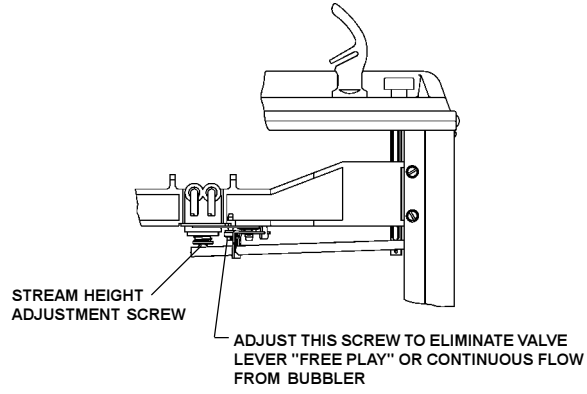

FIG. 3

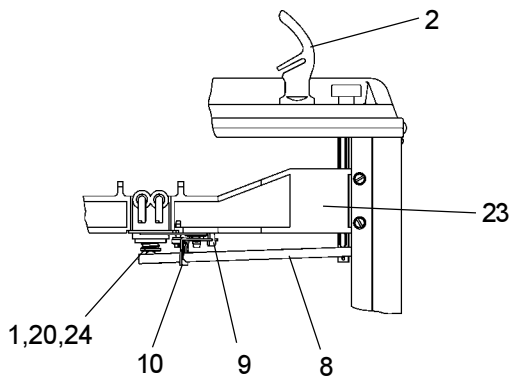
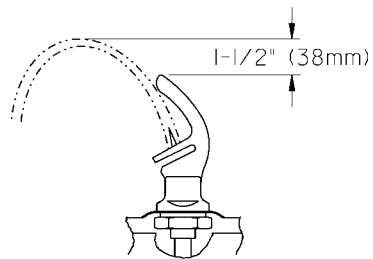

FIG. 4



CORRECT STREAM HEIGHT

FIG. 5

ITEMIZED PARTS LIST

ITEM NO.	PART NO.	DESCRIPTION
1	15005C	Nut-Regulator Retaining
2	51544C	Bubbler
3	10-15075-31-550	Push Button Stem
4	10-14534-31-640	Cap Push Button
5	10-26399-31-640	Drain Plug
6	16-02705-08-640	Strainer Plate
7	17-14037-42-590	Basin
8	26860C	Regulator Lever
9	26861C	Pivot Bracket
10	26862C	Regulator Retaining Bracket
11	31513C	Cold Control
12*	35762C	Compressor Service Pak
13	31027C	Overload/Relay Assy
14	35766C	Relay Cover
15	19-42439-01-550	Electrical Shield
16	19-26684-51-550	Power Cord
17	45688C	Precooler
18	66229C	Heat Exchanger
19	40136C	Water Temperature Valve
20	50986C	Regulator Holder
21	60-14181-51-550	Condenser Assy
22	66506C	Evaporator
23	55880C	Regulator Mounting Bracket
24	61314C	Regulator
25	66202C	Drier
26	75494C	Check Valve
27	55996C	Strainer
28	55913C	Adaptor-Drain W/O Holes
29	55885C	Nut 1-1/4 Slip Joint
30	15008C	Nipple - Bubbler
31	70682C	Tee - 1/4
32	See Color Table	Side Panel - Right
33	See Color Table	Side Panel - Left
NS	See Color Table	Front Panel

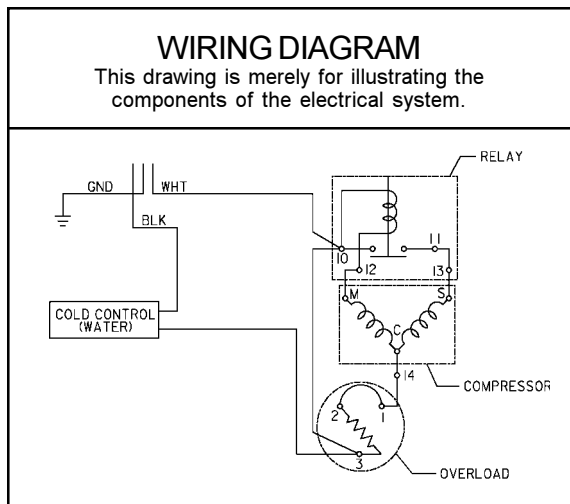

*INCLUDES RELAY & OVERLOAD. IF UNDER WARRANTY, REPLACE WITH SAME COMPRESSOR USED IN ORIGINAL ASSEMBLY.

NOTE: All correspondence pertaining to any of the above water coolers or orders for repair parts MUST include Model No. and Serial No. of cooler, name and part number of replacement part.

COLOR	RIGHT PANEL	LEFT PANEL	FRONT PANEL
Platinum (PV)	401536248410	401536348410	401507448410
Almond (AV)	26912C	26908C	26904C
Slate (SV)	401536248440	401536348440	401507448440
Stnlss Stl (SS)	401536242830	401536342830	401507442830

CONDENSER WATER VALVE ADJUSTMENT

The condenser water valve is factory preset for a condenser water outlet temperature of 95° to 105° F. If actual temperature varies greatly from this, readjust water flow rate at the valve using the following procedures.

1. START UP COMPRESSOR

This can be accomplished by depressing the cooler push button (See Fig. 1 - Item 4). Keep water running during the entire readjustment procedure.

2. ADJUSTMENT CONDENSER WATER VALVE

Adjust valve by rotating adjustment stem. Rotating stem clockwise will decrease water flow. Counterclockwise rotation will increase water flow. Increasing water flow will result in a lower condenser outlet temperature, while decreasing water flow will result in a higher outlet temperature. Proper adjustment is attained when condenser outlet temperature is 95° to 105° F.

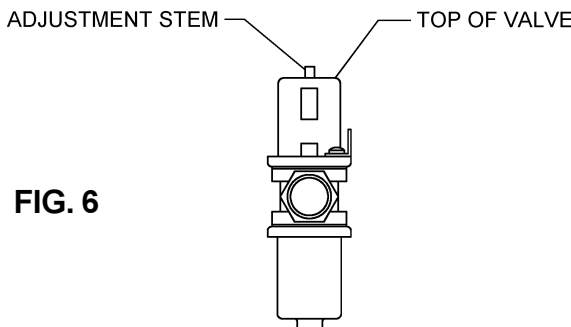

FIG. 6

Halsey Taylor
2222 CAMDEN COURT
OAK BROOK, IL 60523