

MODELS SW4, SW6, SW8 and SW13 (May 1979 and older)

SW4, SW6, SW8 and SW13 PART LIST

REF NO.	PART NUMBER	DESCRIPTION	SW4	SW6	SW8	SW13
1	10-03165-08-640	Projector	X	X	X	X
2	10-03227-40-560	Projector Gasket (2 each)	X	X	X	X
3	16-06092-08-550	Projector Nipple	X	X	X	X
4	60-14800-51-550	Regulator Assembly*	X	X	X	X
4a	60-14549-51-550	Valve Body Assembly (for item 4)*	X	X	X	X
4b	60-08050-51-550	Diaphragm Repair Kit (for item 4a)*	X	X	X	X
4c	60-14202-51-550	Stem Assembly (included in item 4)*	X	X	X	X
5	60-07553-51-590	Push Button Assembly*	X	X	X	X
6	40-26741-43-730	Lever Arm	X	X	X	X
7	10-26399-31-640	Drain Plug	X		X	
7	16-16373-08-640	Drain Plug		X		X
8	16-02705-08-640	Strainer Plate	X	X	X	X
9	10-01471-40-560	Waste Gasket	X	X	X	X
10	NO LONGER AVAILABLE	Waste Line	X	X	X	X
11	NO LONGER AVAILABLE	Waste Line & Precooler			X	X
12	60-10187-51-550	Storage Tank	X			
12	NO LONGER AVAILABLE	Storage Tank		X		
12	NO LONGER AVAILABLE	Storage Tank			X	
12	NO LONGER AVAILABLE	Storage Tank				X
13	19-42339-51-550	Primary Temperature Control	X	X	X	X
14	19-15342-51-550	Secondary Temperature Control	X	X	X	X
15	60-07321-51-550	Compressor Assembly	X	X		
15	60-08394-51-550	Compressor Assembly			X	X
15a	19-07396-51-550	Relay (included in 15)	X	X		
15a	19-07765-51-550	Relay (included in 15)			X	X
15b	19-07401-51-550	Overload (included in 15)	X	X		
15b	19-07724-51-550	Overload (included in 15)			X	X
15c	19-10858-82-550	Capacitor (included in 15)			X	X
16	19-10193-51-550	Fan Motor	X	X		
16	19-08054-51-550	Fan Motor			X	X
17	19-06285-04-550	Fan Blade	X	X		
17	19-08417-04-550	Fan Blade			X	X
18	10-06724-43-560	Fan Mounting Bracket	X	X		
18	41-06286-51-730	Fan Mounting Bracket			X	X
19	NO LONGER AVAILABLE	Condenser	X	X		
19	NO LONGER AVAILABLE	Condenser			X	X
20	NO LONGER AVAILABLE	Capillary Heat Exchanger	X	X		
20	29-08473-51-550	Capillary Heat Exchanger			X	X
21	17-07400-42-590	Receptor	X	X	X	X
22	40-06609-43-730	Wall Bracket (not shown)	X	X	X	X
23	10-06876-08-640	Glass Filler Plug Button	X	X	X	X
24	NO LONGER AVAILABLE	Front Panel	X	X	X	X
25	10-10800-51-010	Drier	X	X	X	X

ACCESSORIES AVAILABLE

Glass Filler – See Spec Book
 Glass Filler Installation Kit – 60-09950-51-550
 Vandal Proof Kit – 73-15243-51-640*
 Water Filtration Kits – 73-15242-51-550* (mounts external to cooler)
 73-15423-51-550* (mounts inside cooler)

XXX Please specify color when ordering. See Color Chart on page I-A for colors available.

*See Detailed Parts Section for further breakdown.

MODELS SW4, SW86, SW8, and SW13

MODEL#	MFG DATE S/N ENDING	COLD WATER CAP*	COMP HP	VOLTAGE ± 10	PH	HZ	TOTAL AMPS	R-12 REFRIG CHARGE*	WATER INLET PSIG
SW4	E79 and older	4GPH	1/6	115	1	60	3.5	5.5 oz	20-90
SW6	E79 and older	6GPH	1/6	115	1	60	3.5	5.5 oz	20-90
SW8	E79 and older	8GPH	1/5	115	1	60	5.5	8.0 oz	20-90
SW13	E79 and older	13GPH	1/5	115	1	60	5.5	8.0 oz	20-90
HEIGHT: 23 $\frac{3}{4}$ "			WIDTH: 18 $\frac{1}{8}$ "			DEPTH: 14 $\frac{1}{4}$ "			
*ARI ratings: capacity at GPH cooled to 50° with 90°F ambient temperature and 80°F inlet water.									

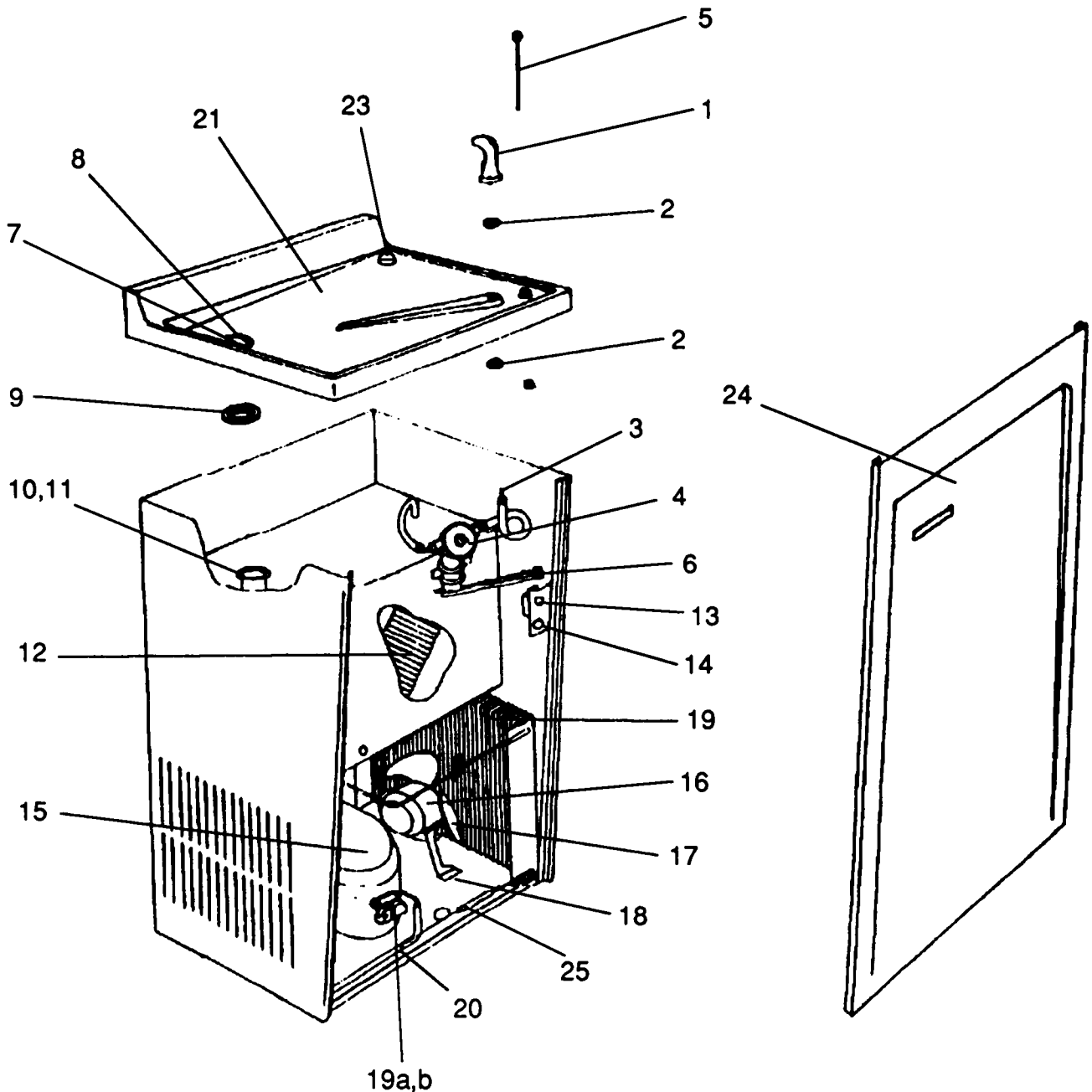

To order parts, contact your nearest Halsey Taylor wholesaler or representative.

Continued product improvement makes specifications subject to change without notice.

Halsey Taylor.