

# MODELS SW4-2, SW8-2 and SW14-2

## SW4-2, SW8-2 and SW14-2 PART LIST

REF NO.	PART NUMBER	DESCRIPTION	SW4-2	SW8-2	SW14-2	SW L/Retrig
1	10-14228-31-640	Projector	X	X	X	X
2	10-03227-40-560	Projector Gasket (2 each)	X	X	X	X
3	16-42252-16-550	Projector Nipple (included in 5)	X	X	X	X
4	60-26229-51-550	Regulator Assembly*	X	X	X	X
4a	60-08050-51-550	Regulator Repair Kit (for item 4)*	X	X	X	X
4b	60-14202-51-550	Stem Assembly (included in item 4a)*	X	X	X	X
5	60-26390-51-550	Projector Supply Line	X	X	X	
5	60-26391-51-550	Projector Supply Line				X
6	60-15889-51-550	Valve to Chiller Supply Line	X	X	X	
6	40-15452-16-550	Supply Line				X
7	10-14532-31-550	Regulator Bracket	X	X	X	X
8	60-14511-51-590	Push Button Assembly*	X	X	X	X
9	10-14523-31-870	Bushing	X	X	X	X
10	40-26741-43-730	Lever Arm	X	X	X	X
11	10-06876-08-XXX	Glass Filler Plug Button	X	X	X	X
12	10-26399-08-XXX	Drain Plug (included in 15A)	X	X	X	X
13	16-02705-08-XXX	Strainer Plate (included in 15A)	X	X	X	X
14	10-01471-40-560	Waste Gasket	X	X	X	X
15A	60-27032-51-550	Precooler Assembly (includes 12, 13)		X	X	
15B	60-27029-51-550	Drain Tube Assembly	X			
15C	60-26391-51-550	Drain Tube				X
16	10-14514-31-550	Precooler Baffle		X	X	
17	60-15488-51-550	Evaporator Chiller	X			
17	60-15489-51-550	Evaporator Chiller		X		
17	60-15528-51-550	Evaporator Chiller			X	
18	19-42339-51-550	Temperature Control	X	X	X	
19	60-15575-51-550	Compressor	X			
19	60-15572-51-550	Compressor		X		
19	60-15573-51-550	Compressor			X	
19a	19-14177-51-550	Relay (included in 19)	X			
19a	19-14891-51-550	Relay (included in 19)		X		
19a	19-14062-51-550	Relay (included in 19)			X	
19b	19-14178-51-550	Overload (included in 19)	X			
19b	19-14894-51-550	Overload (included in 19)		X		
19b	19-14061-51-550	Overload (included in 19)			X	
20	19-14761-51-550	Fan Motor	X	X	X	
21	SEE FAN NOTE**	Fan Blade**	X	X	X	
22	40-26720-43-730	Fan Bracket	X	X	X	
23	19-15079-51-550	Condenser	X	X		
23	19-15080-51-550	Condenser			X	
24	10-14528-31-560	Fan Shroud		X	X	
25	10-10800-51-010	Drier	X	X	X	
26	17-14548-42-590	Receptor	X	X	X	X
27	40-06609-43-730	Receptor Hanger (not shown)	X	X	X	X
28	11-26275-43-890	Receptor Screws (4 each)	X	X	X	X
29	40-14505-43-XXX	Front Panel (not shown)	X	X	X	X
30	40-14503-43-XXX	Right Side Panel	X	X	X	X
31	40-14504-43-XXX	Left Side Panel	X	X	X	X
32	10-15431-51-550	Back Bumper (2 each)	X	X	X	X
33	11-10083-43-890	Panel Screws (48 each)	X	X	X	X
34	13-14905-31-920	Name Plate (not shown)	X	X	X	X
35	40-15077-43-730	Shelf	X	X	X	X
36	40-14748-43-730	Tie Bar	X	X	X	X
37	19-26679-51-550	Wiring Assembly	X	X	X	
38	10-14517-31-550	Side Frames (2 each)	X	X	X	X
39	40-26030-43-730	Base	X	X	X	X
40	29-14356-16-550	Capillary Tube	X	X		
40	29-14371-16-550	Capillary Tube			X	

### ACCESSORIES AVAILABLE

Glass Filler - See Spec Book

Glass Filler Kit - 73-26285-51-550 (Does Not include Glass Filler)

Water Filtration Kit - 73-15242-51-550\* (Installed external to cooler)

73-15423-51-550\* (Installed inside cooler)

Vandal Proof Kit - 73-15243-51-640\*

XXX Please specify color when ordering. See Color Chart on page I-A for colors available.

\*See Detailed Parts Section for further breakdown.

\*\*FAN NOTE: If current fan blade screws on, use 10-42094-43-730. If it doesn't, use a 10-42343-43-730

# MODELS SW4-2, SW8-2 and SW14-2

MODEL#	MFG DATE S/N ENDING	COLD WATER CAP*	COMP HP	VOLTAGE ± 10	PH	HZ	TOTAL AMPS	R-12 REFRIG CHARGE*	WATER INLET PSIG
SW4-2	F87 - J88	4GPH	1/10	115	1	60	2.4	5.75 oz	20-90
SW8-2	F87 - H88	8GPH	1/8	115	1	60	3.1	6.5 oz	20-90
SW14-2	F87 - A89	14GPH	1/5	115	1	60	4.8	8.1 oz	20-90
HEIGHT: 23"			WIDTH: 18 1/4"			DEPTH: 14 1/4"			
*ARI Ratings: capacity at GPH cooled to 50° with 90°F ambient temperature and 80°F inlet water.									

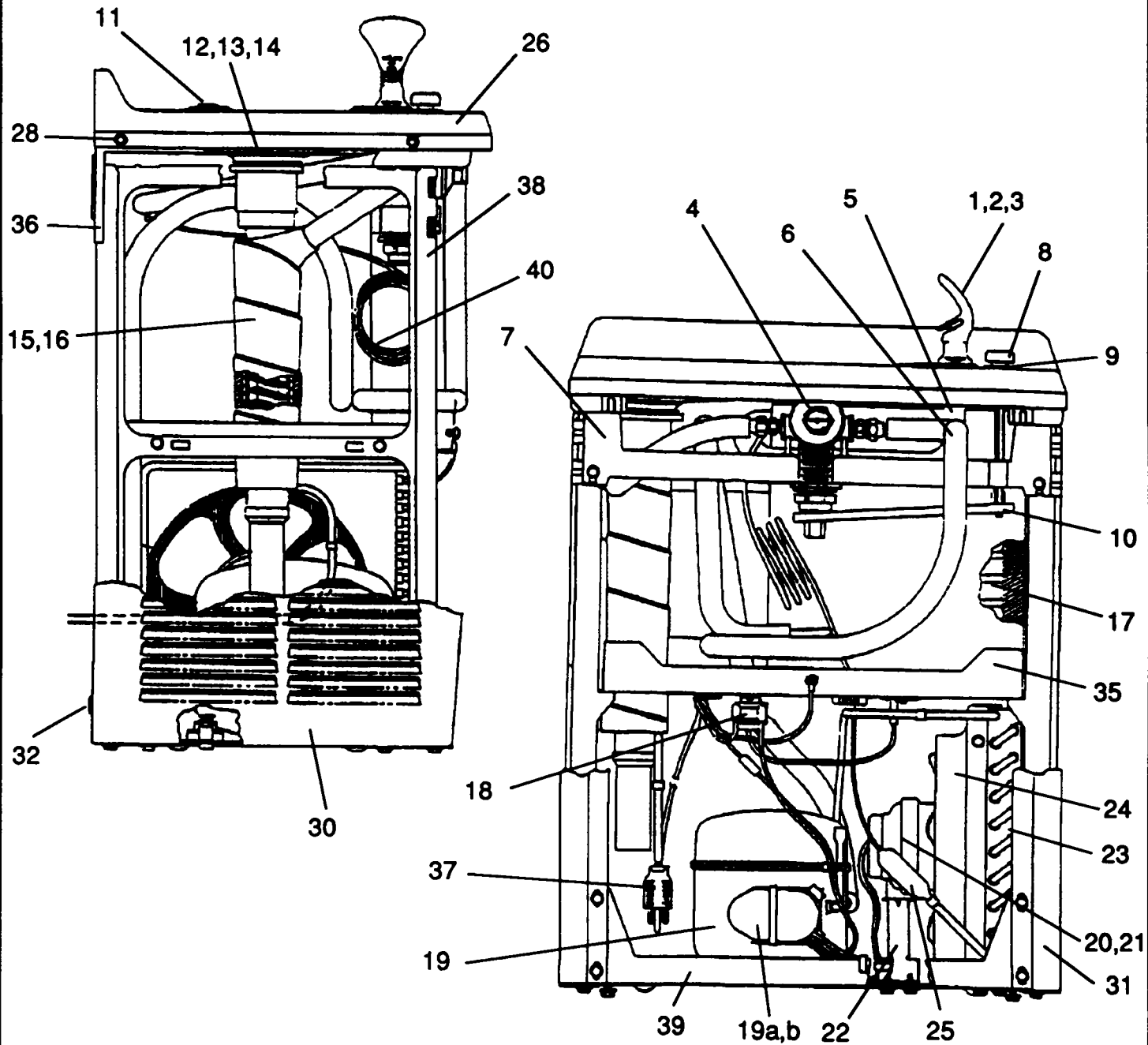

**To order parts, contact your nearest Halsey Taylor wholesaler or representative.**  
 Continued product improvement makes specifications subject to change without notice.

*Halsey Taylor.*