

Halsey Taylor Owners Manual

USES HFC-134A REFRIGERANT

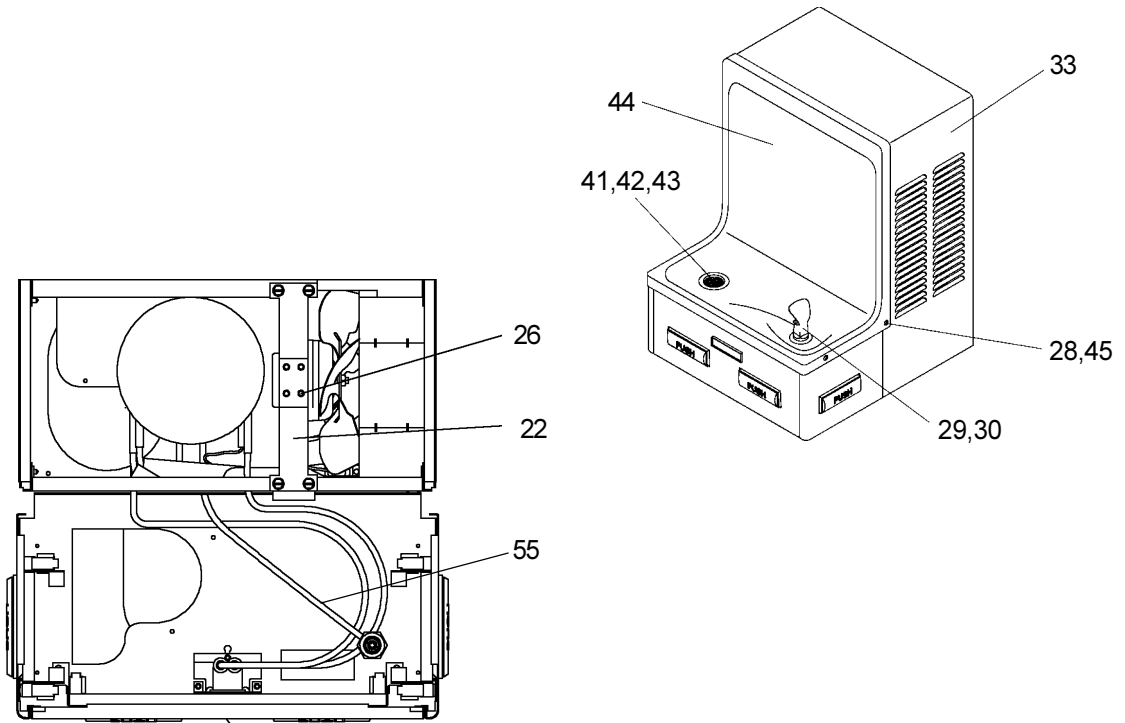

See Fig. 3 (on Page 3)
For Push Bar Mechanism

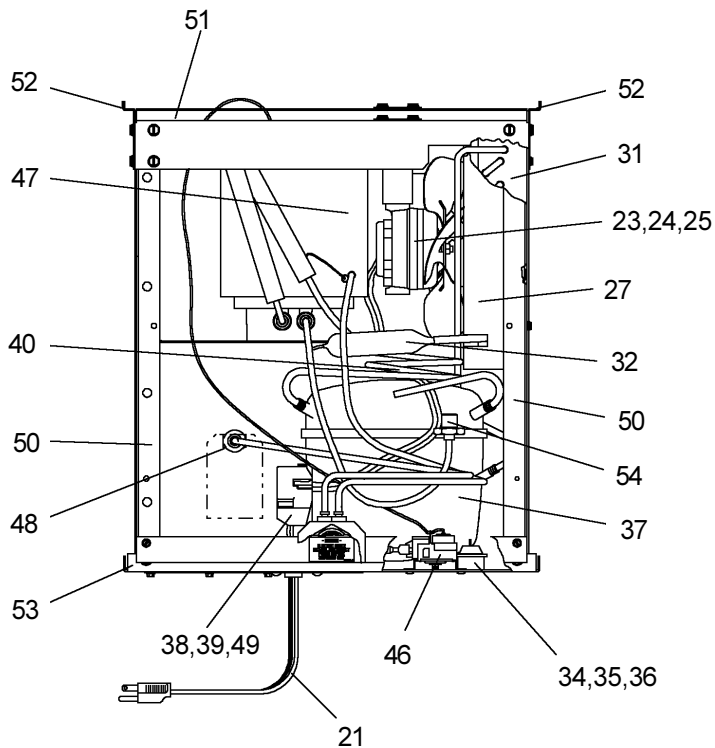

FIG. 1

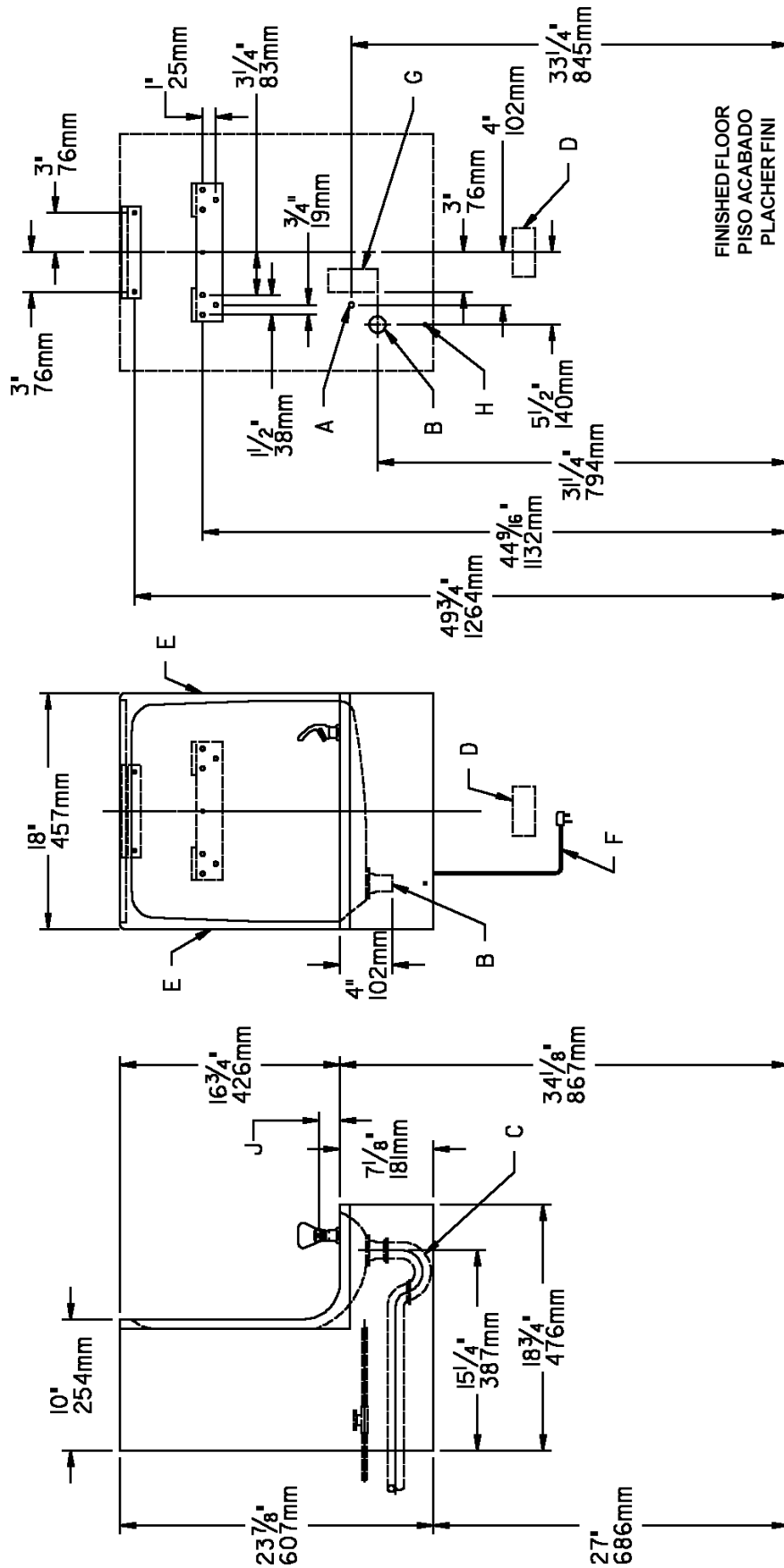

FIG. 2

- LEGEND/LEYENDA/LÉGENDE**
A = RECOMMENDED WATER SUPPLY LOCATION 3/8 O.D. UNPLATED COPPER TUBE CONNECT STUB 1-1/2 IN. (38mm) OUT FROM WALL SHUT OFF BY OTHERS
 SE RECOMIENDA UBICAR EL TUBO CORTO DE CONEXIÓN AL TUBO DE COBRE SIN CHAPAR DE 3/8" DE DIÁM. EXT. A 1-1/2" (38mm) FUERA DE LA Llave DE PASO EN LA PARED COLOCADA POR TERCEROS.
B = RECOMMENDED LOCATION FOR WASTE OUTLET 1-1/4" O.D. DRAIN
 UBICACIÓN RECOMENDADA PARA EL DRENAJE DE SALIDA DE AGUA, DE 1 1/4" DE DIÁMETRO.
C = 1-1/4" TRAP NOT FURNISHED**
 EMPACEMENT RECOMMANDÉ POUR LE DRAIN DE D.E. 1-1/4" DE SORTIE D'EAU.
D = ELECTRICAL OUTLET LOCATION
 UBICACIÓN DE LA TOMA DE ELECTRICIDAD
 EMPACEMENT DE LA PRISE DE COURANT
- E = INSURE PROPER VENTILATION BY MAINTAINING 6" (152mm) (MIN.) CLEARANCE FROM CABINET LOUVERS TO WALL.**
 ASEGURE UNA VENTILACIÓN ADECUADA MANTENIENDO UN ESPACIO E 6" (152mm) (MÍN.) DE HOLGURA ENTRE LA REJILLA DE VENTILACIÓN DEL MUEBLE Y LA PARED
 ASSUREZ-VOUS UNE BONNE VENTILATION EN GARDANT 6" (152mm) (MIN.) ENTRE LES ÉVÉNEMENTS DE L'ENCEINTE ET LE MUR
- F = POWER CORD 1-1/2 FEET (457mm) LONG**
 CABLE ELÉCTRICO DE 1 1/2 PIE. 457 mm DE LARGO
 CORDON D'ALIMENTATION 1-1/2' (457mm)
- G = ALT. ELECTRICAL OUTLET LOCATION**
 UBICACION ALT. DE LA TOMA DE ELECTRICIDAD
 EMPLACEMENT ALTERNATIF DE LA PRISE DE COURANT
- H = THIS BOLT HOLE MUST BE USED FOR FASTENING UNIT TO WALL**
 ESTE AGUJERO DE TUERCA DEBERÁ SER USADO PARA ASEGURAR LA UNIDAD A LA PARED.
 ON DOIT UTILISER CE TROU DE BOULON POUR INSTALLER L'APPAREIL AU MUR.
- J = ORIFICE HEIGHT 1-1/4" (32mm) ABOVE RIM**
 ALTURA DEL ORIFICIO 1-1/4" (32mm) SOBRE LA CORONA
 HAUTEUR DE L'ORIFICE 1-1/4" (32mm) AU DESSUS DU REBORD

PUSH BAR MECHANISM

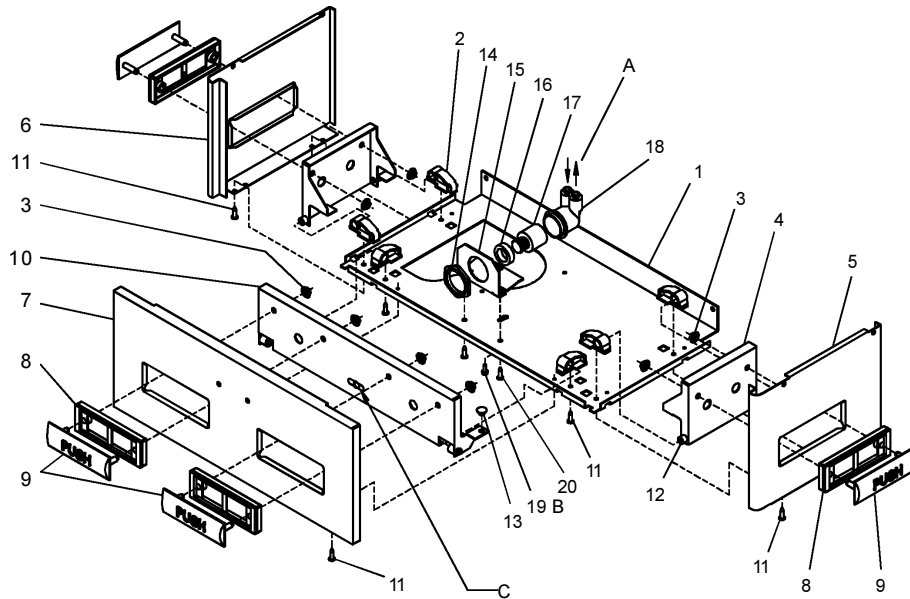

FIG. 3

Water Valve Mechanism - ADJUSTMENT PROCEDURE:

- Turn adjustment screw (Item 19) "Counter-Clockwise" until water flow from bubbler starts.
- Turn adjustment screw "Clockwise" until water flow stops, THEN turn an additional 1/2 turn.

NOTE: Adjustments stated above are viewed from underneath unit (bottom side of dispenser panel Item 1)

NOTE: If continuous flow occurs at the end of the compressor cycle, turn cold control (Item 46) counterclockwise 1/4 turn.

LEGEND

- A) Note: Water flow direction**
- B) Adjust this screw to eliminate mechanism "Free Play" or continuous flow from bubbler conditions. (See ADJUSTMENT PROCEDURE)**
- C) Stream height adjustment (see note #8)**

HANGER BRACKETS & TRAP INSTALLATION

- 1) Remove hanger bracket fastened to back of cooler by removing one (1) screw.
- 2) Mount the hanger bracket and trap as shown in Figure 2. **NOTE:** Hanger Bracket **MUST** be supported securely. Add fixture support carrier if wall will not provide adequate support.

IMPORTANT:

- 5-1/2 in. (140mm) dimension from centerline of unit to centerline of trap must be maintained for proper fit.
 - Anchor hanger securely to wall using all mounting holes.
- 3) Install straight valve for 3/8" O.D. unplated copper tube.

INSTALLATION OF COOLER

- 4) Hang the cooler on the hanger bracket. Be certain the hanger bracket is engaged properly in the slots on the cooler back as shown in Figure 2.
- 5) Loosen the two (2) screws holding the lower front panel at the bottom of cooler base and two (2) screws at the top. Remove the front panel and set aside.
- 6) Connect water inlet line--See Note 4 of General Instructions.
- 7) Remove the slip nut and gasket from the trap and install them on the cooler waste line making sure that the end of the waste line fits into the trap. Assemble the slip nut and gasket to the trap and tighten securely.

START UP

Also See General Instructions

- 8) Stream height is factory set at 35 PSI. If supply pressure varies greatly from this, adjust screw, accessible by removing front panel (Item 7, Fig. 3). CW adjustment will raise stream and CCW adjustment will lower stream. For best adjustment, stream should hit basin approximately 6-1/2" (165mm) from bubbler.
- 9) Replace the front panel and secure by retightening four (4) screws.

ITEM NO.	PART NO.	DESCRIPTION
1	26588C	Panel - Bottom Dispenser
2	51531C	Block - Pivot
3	111411743620	Nut - 1/4", Self-Threading
4	22901C	Bracket - Side Push
5	See Color Table	Panel - Right Side
6	See Color Table	Panel - Left Side
7	See Color Table	Panel - Front Push
8	55859C	Pushbar - Side & Front
9	55947C	Insert - Push Bar
10	22900C	Bracket - Front Push
11	70864C	Screw - #8 x 5/8" Torx/slotted
12	50212C	Rivet - Drive Type
13	51667C	Bumper - Press Bar
14	40045C	Hex Nut
15	23003C	Bracket - Regulator Mounting
16	15005C	Retaining Nut
17	61314C	Regulator
18	50986C	Holder - Regulator
19	70935C	Screw - Shoulder x 1/2" Lg.
20	112627543890	Screw - Regulator Brkt. Mtg.

COLOR TABLE

PANEL COLOR	Item No. 5 Part No. (w/o hole)	Item No. 5 Part No. (with hole)	Item No. 6 Part No. (w/o hole)	Item No. 6 Part No. (with hole)	Item No. 7 Part No.
Platinum Vinyl	26644C	26659C	26614C	26629C	26599C
Stainless Steel	26637C	26652C	26607C	26622C	26600C
Almond Vinyl	26636C	26651C	26606C	26621C	26601C
Slate Vinyl	26646C	26661C	26616C	26631C	26602C

115V PARTS LIST

ITEM NO.	PART NO.	DESCRIPTION
21	31517C	Power Cord
22	27095C	Fan Bracket
23	30699C	Fan Blade
24	70018C	Hex Nut - Fan Blade
25	31490C	Fan Motor (115v)
26	70009C	Screw - #8-36 x 3/8" Lg. (Fan Motor)
27	50186C	Shroud - Fan
28	70142C	Clip (Front and Rear Panels)
29	51544C	Bubbler - Chrome
30	100322740560	Gasket - Bubbler (upper and lower)
31	62152C	Condenser
32	66202C	Drier
33	26680C	Wrapper - Platinum Vinyl
	26682C	Wrapper - Slate Vinyl
	22707C	Wrapper - Almond Vinyl
	22708C	Wrapper - Stainless Steel
34	50144C	Grommet - Compressor Mtg.
35	70184C	Hair Pin - Cotter
36	70418C	Washer
37*	36094C	Compressor Serv. Pak EMI 70 HNR
38	36158C	Overload
39	35768C	Cover - Relay
40	66501C	Heat Exchanger
41	40572C	Tailpipe
42	40575C	Strainer Assy - Basin
43	50074C	Gasket - Tailpipe
44	26664C	Basin - Stainless Steel
45	75536C	Screw - Basin Mtg.
46	31513C	Cold Control
47	66505C	Evaporator Assembly
48	55996C	Strainer
49	35959C	Relay
50	27093C	Angle - Bracket Corner
51	27094C	Bracket - Front Support
52	27096C	Bracket - Basin Mounting
53	27097C	Frame - Back/Bottom
54	56159C	Nipple - Bubbler
55	56092C	Tubing - Poly (Cut to Length)

230V-50Hz PARTS LIST

21	35827C	Power Cord
25	31430C	Fan Motor
37*	36085C	Compressor Serv. Pak
38	36195C	Overload
49	36050C	Relay
-	35826C	Power - Inlet

*INCLUDES RELAY & OVERLOAD. IF UNDER WARRANTY, REPLACE WITH SAME COMPRESSOR USED IN ORIGINAL ASSEMBLY.

NOTE: All correspondence pertaining to any of the above water coolers or orders for repair parts MUST include Model No. and Serial No. of cooler, name and part number of replacement part.

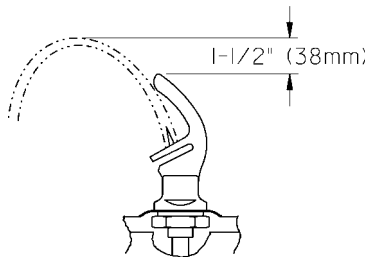

CORRECT STREAM HEIGHT

FIG. 4

Halsey Taylor

2222 CAMDEN COURT
OAK BROOK, IL 60523

PRINTED IN U.S.A.

www.DrinkingFountainDoctor.com

800-518-5388