

Halsey Taylor Owners Manual

USES HFC-134A REFRIGERANT

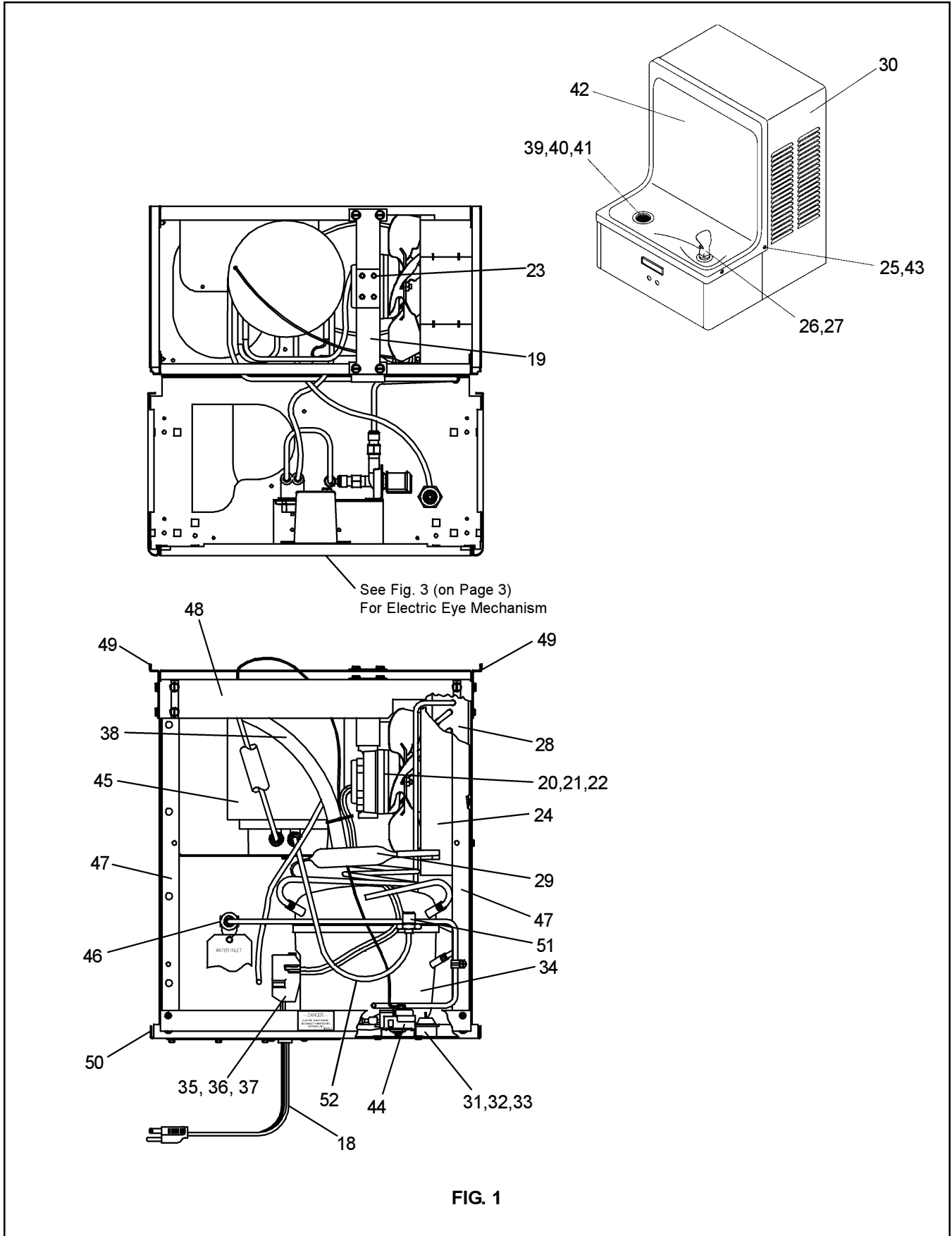

FIG. 1

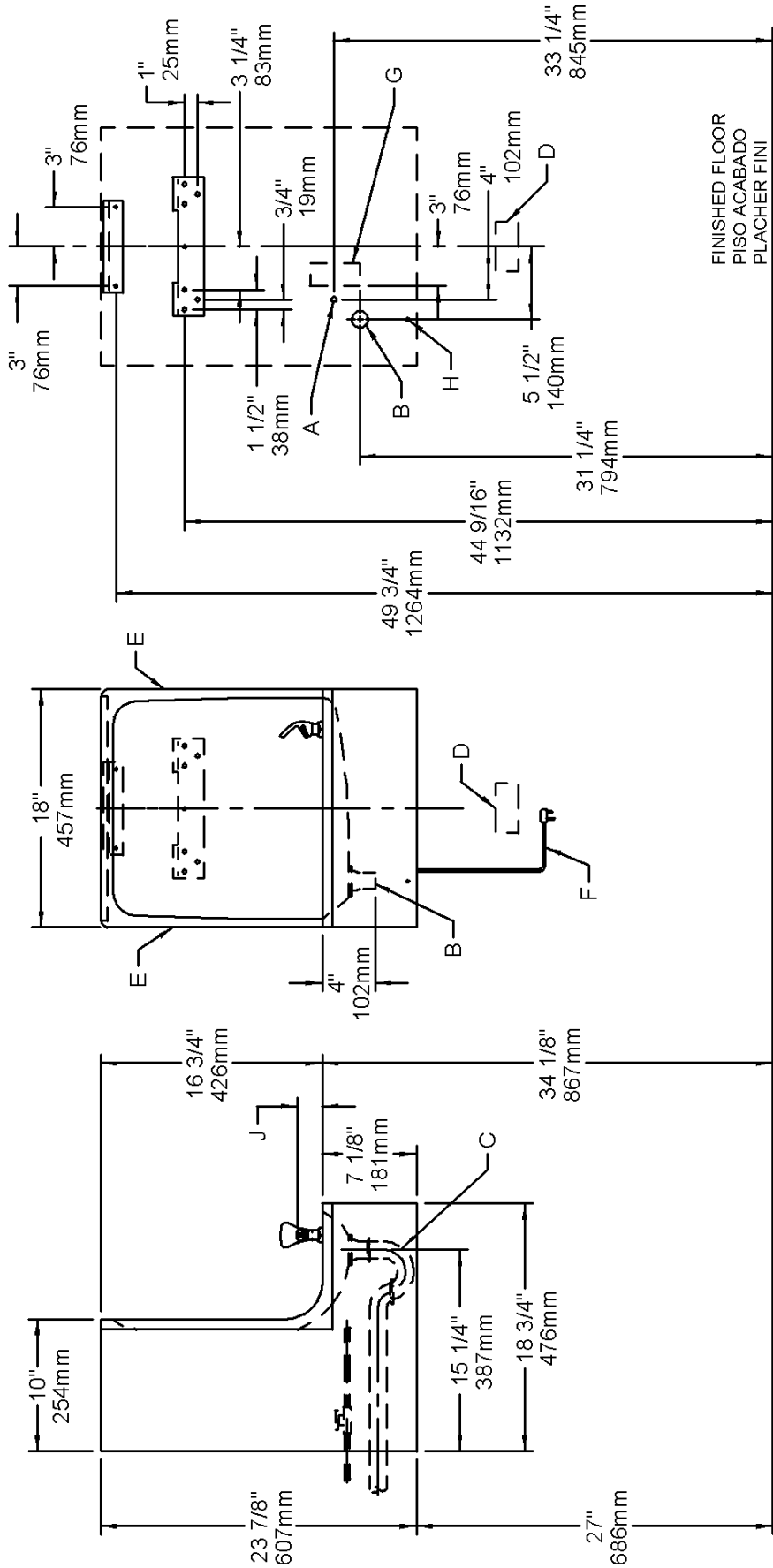

FIG. 2

LEGEND/LEYENDA/LÉGENDE
A = RECOMMENDED WATER SUPPLY LOCATION 3/8 O.D. UNPLATED COPPER TUBE CONNECT STUB 1-1/2 IN. (38mm) OUT FROM WALL SHUT OFF BY OTHERS
 SE RECOMIENDA UBICAR EL TUBO CORTO DE CONEXIÓN AL TUBO DE COBRE SIN CHAPAR DE 3/8" DE DIÁM. EXT. A 1-1/2" (38mm) FUERA DE LA LLAVE DE PASO EN LA PARED COLOCADA POR TERCEROS.
 EMPLACEMENT RECOMMANDÉ D'ALIMENTATION EN EAU PAR TUBE EN CUIVRE NON PLAQUÉ DE 3/8 PO. (9.5 mm) D.E. CONNECTANT UNE TUYAUTERIE DE 1-1/2 PO. (38mm) DEPUIS LE ROBINET D'ARRÊT FOURNI PAR D'AUTRES.

B = RECOMMENDED LOCATION FOR WASTE OUTLET 1-1/4" O.D. DRAIN
 UBICACIÓN RECOMENDADA PARA EL DRENAJE DE SALIDA DE AGUA, DE 1 1/4" DE DIÁMETRO.
 EMPLACEMENT RECOMMANDÉ POUR LE DRAIN DE D.E. 1-1/4" DE SORTIE D'EAU.

C = 1-1/4 TRAP NOT FURNISHED**
 PURGADOR DE 1 1/4 NO PROPORCIONADO**
 SIPHON 1-1/4 NON FOURNI**

D = ELECTRICAL OUTLET LOCATION
 UBICACIÓN DE LA TOMA DE ELECTRICIDAD
 EMPLACEMENT DE LA PRISE DE COURANT

E = INSURE PROPER VENTILATION BY MAINTAINING 6" (152mm) (MIN.) CLEARANCE FROM CABINET LOUVERS TO WALL. ASEGURE UNA VENTILACIÓN ADECUADA MANTENIENDO UN ESPACIO E 6" (152mm) (MÍN.) DE HOLGURA ENTRE LA REJILLA DE VENTILACIÓN DEL MUEBLE Y LA PARED
 ASSUREZ-VOUS UNE BONNE VENTILATION EN GARDANT 6" (152mm) (MIN.) ENTRE LES ÉVÉNENTS DE L'ENCEINTE ET LE MUR

F = POWER CORD 1-1/2 FEET (457mm) LONG
 CABLE ELÉCTRICO DE 1 1/2 PIE. 457 mm DE LARGO
 CORDON D'ALIMENTATION 1-1/2' (457mm)

G = ALT. ELECTRICAL OUTLET LOCATION
 UBICACION ALT. DE LA TOMA DE ELECTRICIDAD
 EMPLACEMENT ALTERNATIF DE LA PRISE DE COURANT

H = THIS BOLT HOLE MUST BE USED FOR FASTENING UNIT TO WALL.
 ESTE AGUJERO DE TUERCA DEBERÁ SER USADO PARA ASEGURAR LA UNIDAD A LA PARED.
 ON DOIT UTILISER CE TROU DE BOLLON POUR INSTALLER L'APPAREIL AU MUR.

J = ORIFICE HEIGHT 1-1/4" (32mm) ABOVE RIM
 ALTURA DEL ORIFICIO 1-1/4" (32mm) SOBRE LA CORONA
 HAUTEUR DE L'ORIFICE 1-1/4" (32mm) AUDESSUS DU REBORD

ELECTRIC EYE MECHANISM

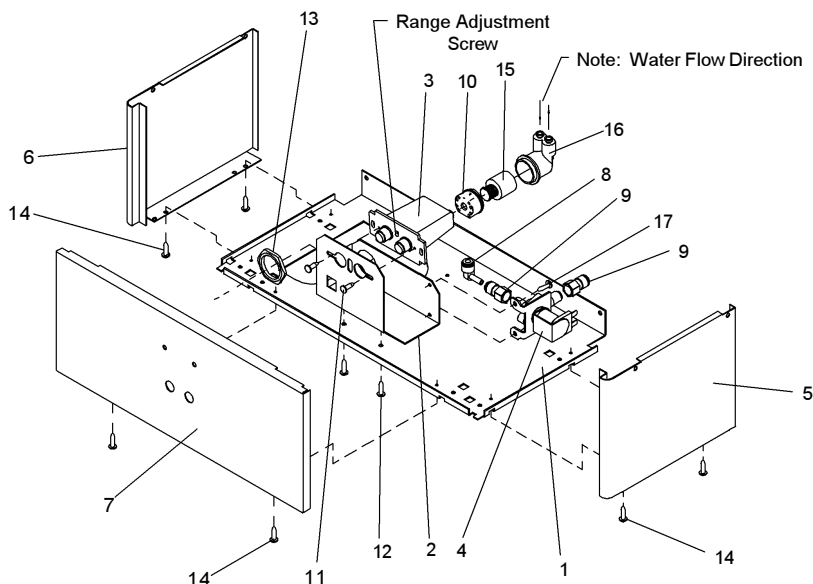

FIG. 3

Sensor Control: If sensor fails to operate valve mechanism or operates erratically, check the following.
 a. Ensure there are no obstructions within a 40-inch radius from front of cooler.
 b. Check wire connections at solenoid valve and sensor.
 CAUTION: Make sure unit is unplugged before checking any wiring.
 c. Ensure proper operation of solenoid valve. If there is an audible clicking sound yet no water flows, look for an obstruction in the valve itself or elsewhere in the water supply line.

Sensor Range Adjustment: The electronic sensor used in this cooler is factory pre-set for a "visual" range of 36 inches. If actual range varies greatly from this, or a different setting is desired, follow the range adjustment procedure below:
 a. Remove front panel of cooler.
 b. Using a small tip screwdriver, rotate range adjustment screw clockwise to increase range and counter-clockwise to decrease range. (See Fig. 3).
 CAUTION: Complete range of sensor (24-48 inches) is only one turn of the adjusting screw.
 c. Replace the front panel.

HANGER BRACKETS & TRAP INSTALLATION

- 1) Remove hanger bracket fastened to back of cooler by removing one (1) screw.
 - 2) Mount the hanger bracket and trap as shown in Figure 2.
NOTE: Hanger Bracket **MUST** be supported securely. Add fixture support carrier if wall will not provide adequate support.
- IMPORTANT:**
- 7-3/4 in. (197mm) dimension from wall to centerline of trap must be maintained for proper fit.
 - Anchor hanger securely to wall using all six (6) 1/4 in. dia. mounting holes.
- 3) Install straight valve for 3/8" O.D. unplated copper tube.

INSTALLATION OF COOLER

- 4) Hang the cooler on the hanger bracket. Be certain the hanger bracket is engaged properly in the slots on the cooler back as shown in Figure 2.
- 5) Loosen the two (2) screws holding the lower front panel at the bottom of cooler base and two (2) screws at the top. Remove the front panel and set aside.
- 6) Connect water inlet line--See Note 4 of General Instructions.
- 7) Remove the slip nut and gasket from the trap and install them on the cooler waste line making sure that the end of the waste line fits into the trap. Assemble the slip nut and gasket to the trap and tighten securely.

START UP

Also See General Instructions

- 8) Stream height is factory set at 35 PSI. If supply pressure varies greatly from this, adjust screw, accessible by removing front panel (Item 7, Fig. 3). CW adjustment will raise stream and CCW adjustment will lower stream. For best adjustment, stream should hit basin approximately 6-1/2" (165mm) from bubbler.
- 9) Replace the front panel and secure by retightening four (4) screws.

ITEM NO.	PART NO.	DESCRIPTION
1	26588C	Panel - Bottom Dispenser
2	26866C	Bracket - Valve Mounting
3	31516C	Sensor - Clear (115v)
	35783C	Sensor - Clear (230v)
4	31272C	Solenoid Valve (115v)
	35784C	Solenoid Valve (230v)
5	See Color Table	Panel - Right Side
6	See Color Table	Panel - Left Side
7	See Color Table	Panel - Front
8	70817C	Elbow 1/4 Stem x 1/4 O.D.
9	75507C	Fitting 1/4 NPTF x 1/4 O.D.
10	56082C	Nut- Regulator
11	70644C	Screw #6-32 x 1/2 Lg PHMS
12	75497C	Screw #10 x 1/2 Lg PHSM
13	40045C	Hex Nut
14	70864C	Screw #8 x 5/8 Lg Torx/Slotted
15	61314C	Regulator
16	50986C	Regulator Holder
17	70002C	Screw #10 x 1/2 Lg HHSM

COLOR TABLE

PANEL COLOR	Item No. 5 Part No.	Item No. 6 Part No.	Item No. 7 Part No.
Platinum Vinyl	26644C	26614C	26740C
Stainless Steel	26607C	26637C	26733C

PARTS LIST 115V

ITEM NO.	PART NO.	DESCRIPTION
18	31483C	Power Cord
19	27095C	Fan Bracket
20	30699C	Fan Blade
21	70018C	Hex Nut - Fan Blade
22	31490C	Fan Motor
23	70009C	Screw - (Fan Motor)
24	50186C	Shroud - Fan
25	70241C	Clip (Front and Rear Panels)
26	51544C	Bubbler - Chrome
27	100322740560	Gasket - Bubbler (upper and lower)
28	62152C	Condenser
29	66202C	Drier
30	26680C	Wrapper - Platinum
	22708C	Wrapper-Stainless Steel
31	50144C	Grommet - Compressor Mtg.
32	70184C	Hair Pin - Cotter
33	70150C	Washer
34	35960C	Compressor Serv. Pak EM65
35	35958C	Overload
36	35768C	Cover - Relay
37*	35959C	Relay
38	66501C	Heat Exchanger
39	40572C	Tailpipe
40	40575C	Strainer Assy - Basin
41	50074C	Gasket - Tailpipe
42	26664C	Basin - Stainless Steel
43	70208C	Screw - Basin Mtg.
44	31513C	Cold Control
45	66505C	Evaporator Assembly
46	55996C	Strainer
47	27093C	Angle - Front Corner
48	27094C	Bracket - Front Support
49	27096C	Bracket - Basin Mounting
50	27097C	Frame - Back/Bottom
51	15008C	Nipple - Bubbler
52	56092C	Poly Tubing 48" (Cut To Length)

PARTS LIST 230V

ITEM NO.	PART NO.	DESCRIPTION
25	31430C	Fan Motor
37*	35763C	Compressor Serv. Pak
38	31024C	Overload/Relay
40	35768C	Cover - Relay
41	66249C	Heat Exchanger
-	194243901550	Cover - Electrical Shield

WIRING DIAGRAM

This Drawing is merely for illustrating the components of the electrical system.

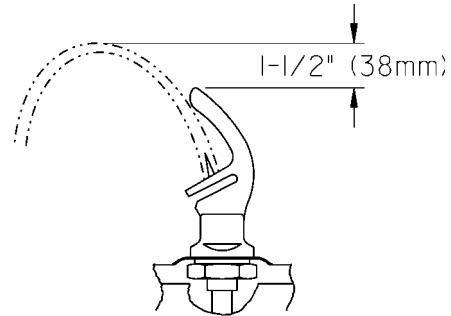
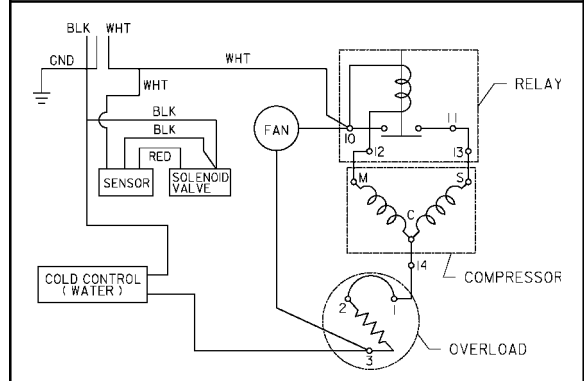

CORRECT STREAM HEIGHT

FIG. 4

***INCLUDES RELAY & OVERLOAD. IF UNDER WARRANTY, REPLACE WITH SAME COMPRESSOR USED IN ORIGINAL ASSEMBLY.**

NOTE: All correspondence pertaining to any of the above water coolers or orders for repair parts MUST include Model No. and Serial No. of cooler, name and part number of replacement part.