

# MODELS WM14-1BL and 16-1BL

## WM14-1BL and WM16-1BL PART LIST

REF NO.	PART NUMBER	DESCRIPTION	WM 14-1BL	WM 16-1BL	BL-301
1	10-14228-31-640	Projector	X	X	X
2	10-03227-40-560	Projector Gasket (2 each)	X	X	X
3	10-14224-31-550	Projector Nipple	X	X	X
4	60-14800-51-550	Regulator Assembly*	X	X	X
4a	60-14549-51-550	Valve Assembly (included in item 4)	X	X	X
4b	60-08050-51-550	Diaphragm Repair Kit* (for item 4)	X	X	X
4c	60-14202-51-550	Valve Stem Assembly* (included in item 4)	X	X	X
5	62-15959-51-550	Push Button Stem Assembly			X
5	60-14511-51-550	Push Button Stem Assembly*	X	X	
6	10-14523-31-870	Stem Bushing	X	X	X
7	40-26741-43-730	Lever Arm for Push Button Assembly	X	X	X
8	10-06876-08-640	Glass Filler Plug Button (not shown)	X	X	
9	16-02705-08-640	Strainer Plate (included in item 12)	X	X	X
10	16-16373-08-640	Drain Plug	X		X
10	10-26399-31-640	Drain Plug (included in item 12)	X	X	
11	10-01471-40-560	Waste Gasket	X	X	X
12	60-27042-51-550	Precooler Assembly		X	X
13	16-15286-51-550	Tailpiece			X
14	11-03462-20-550	Locknut			X
15	16-03463-08-640	Slip Nut			X
16	10-03529-40-560	Slip Nut Gasket			X
17	16-07470-51-550	Continuous Waste			X
18	40-14514-31-550	Precooler Baffle	X	X	
19	60-15038-51-550	Evaporator Chiller	X		
19	60-14430-51-550	Evaporator Chiller		X	
20	19-42339-51-550	Temperature Control	X	X	
21	60-15573-51-550	Compressor Assembly	X		
21	60-15574-51-550	Compressor Assembly		X	
21a	19-14062-51-550	Relay (included in item 21)	X		
21a	19-14412-51-550	Relay (included in item 21)		X	
21b	19-14061-51-550	Overload (included in item 21)	X		
21b	19-14895-51-550	Overload (included in item 21)		X	
22	10-14647-82-550	Capacitor		X	
23	19-14761-51-550	Fan Motor	X	X	
24	See Note Below	Fan Blade	X	X	
25	40-26720-43-730	Fan Bracket	X	X	
26	40-14528-31-560	Shroud	X	X	
27	19-15080-51-550	Condenser	X		
27	19-15224-51-550	Condenser		X	
28	10-10800-51-010	Drier	X	X	
29	10-14523-31-550	Valve Bracket	X	X	
30	17-14037-42-590	Receptor			X
30	17-14548-42-590	Receptor	X	X	
31	11-26275-43-890	Receptor Screws (4 each)	X	X	X
32	40-07475-43-730	Hanger Bracket (not shown)			X
32	40-06609-43-730	Hanger Bracket (not shown)	X	X	
33	40-08104-43-XXX	Front Panel (not shown)			X
33	40-14322-43-XXX	Front Panel (not shown)	X	X	
34	40-14710-43-XXX	Left Side Panel (not shown)	X	X	
35	40-14840-43-XXX	Right Side Panel (not shown)	X	X	
36	10-15431-51-550	Back Bumper (not shown)	X	X	
37	11-10083-43-890	Panel Screws	45	45	2
38	40-15077-43-730	Shelf	X	X	
39	40-26030-43-730	Base	X	X	
40	13-14905-31-920	Name Plate (not shown)	X	X	
41	40-14748-43-730	Tie Bar (not shown)	X	X	
42	10-14551-31-550	Side Frames	X	X	
43	19-26779-51-550	Wiring Assembly	X	X	

### ACCESSORIES AVAILABLE

Glass Fillers - See Spec Book  
 Glass Filler Installation Kit - 73-14499-51-550 (Does not include Glass Filler)  
 Vandal Proof Kit - 73-15243-51-640\*  
 Water Filtration Kit - 73-15242-51-550 (mounts external to cooler)

XXX Please specify color when ordering. See Color Chart on page I-A for colors available.

\*See Detailed Parts Section for further breakdown.

# MODELS WM 14-1BL and WM 16-1BL

MODEL#	MFG DATE S/N ENDING	COLD WATER CAP*	COMP H/P	VOLTAGE ± 10	PH	HZ	TOTAL AMPS	R-12 REFRIG CHARGE*	WATER INLET PSIG
WM14A-1BL	A79 - G7	14GPH	1/5	115	1	60	4.8	9.0 oz	20-90
WM16A-1BL	A79 - G7	16GPH	1/4	115	1	60	5.7	8.0 oz	20-90
<b>COOLER - HEIGHT: 28"</b>			<b>WIDTH: 18<sup>1</sup>/<sub>8</sub>"</b>			<b>DEPTH: 14<sup>1</sup>/<sub>4</sub>"</b>			
<b>FOUNTAIN - HEIGHT: 16<sup>5</sup>/<sub>8</sub>"</b>			<b>WIDTH: 15<sup>7</sup>/<sub>8</sub>"</b>			<b>DEPTH: 14<sup>1</sup>/<sub>4</sub>"</b>			

\*ARI ratings: capacity at GPH cooled to 50° with 90°F ambient temperature and 80°F inlet water.

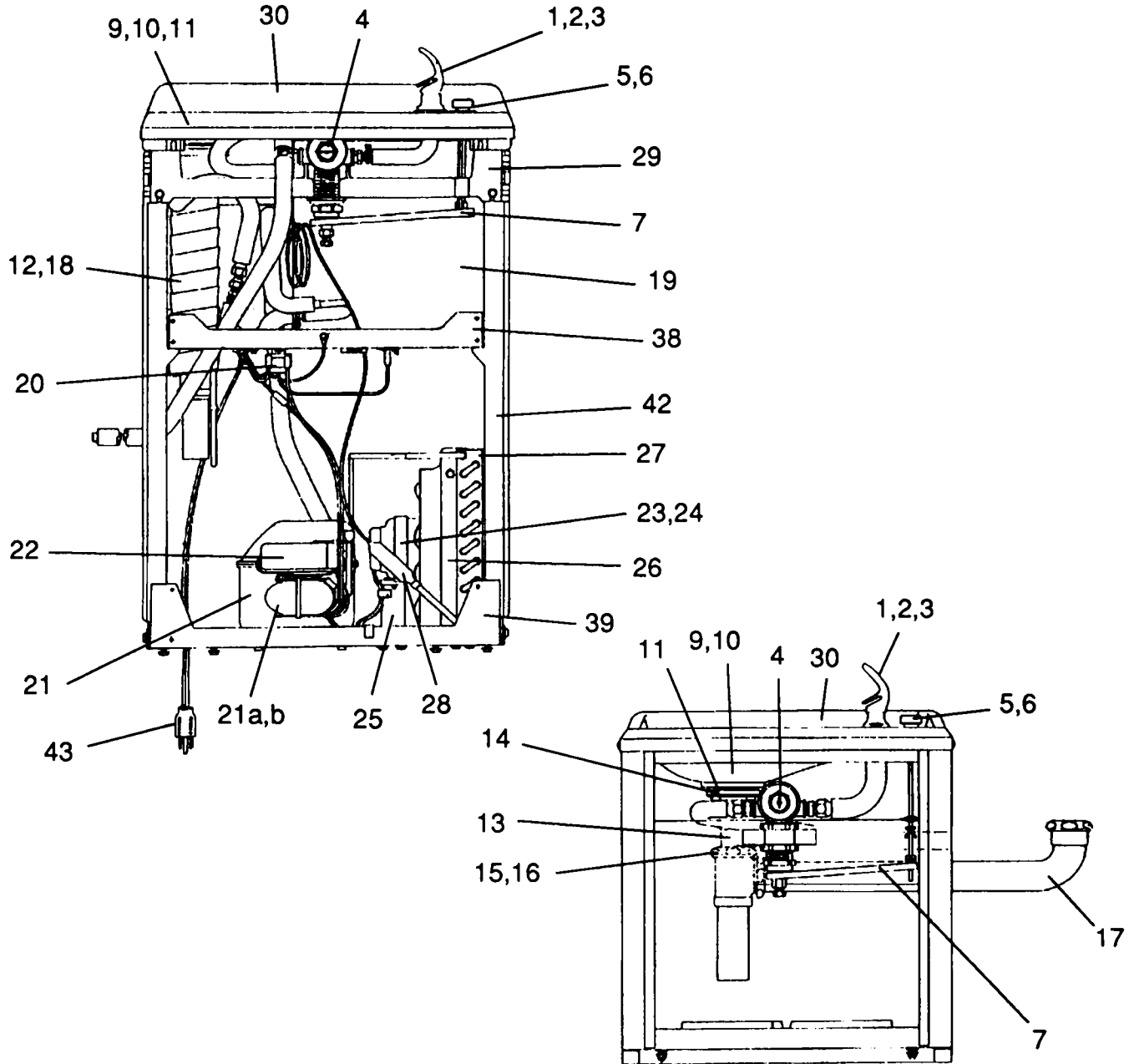

To order parts, contact your nearest Halsey Taylor wholesaler or representative.

Continued product improvement makes specifications subject to change without notice.

*Halsey Taylor.*