

# MODEL WM14-3BL

## WM14-3BL PART LIST

REF NO.	PART NUMBER	DESCRIPTION
1	10-14228-31-640	Projector
2	10-03227-40-560	Projector Gasket (2 each)
3	16-42252-51-550	Projector Nipple (included in item 5)
4	60-26229-51-550	Regulator Assembly*
4a	60-14549-51-550	Valve Assembly (included in item 4*)
4b	60-08050-51-550	Diaphragm Repair Kit* (for item 4)
4c	60-14202-51-550	Valve Stem Assembly* (included in item 4)
5	60-26391-51-550	Projector Supply Line
6	16-15944-08-550	1/4" NPT Cross
7	60-26181-51-550	Valve to Chiller Supply Line
8	62-15959-51-55	Push Button Stem Assembly* (Fountain Side)
8	60-14511-51-550	Push Button Stem Assembly (Cooler Side)
9	10-14523-31-870	Stem Bushing
10	40-26741-43-730	Lever Arm for Push Button Assembly
11	10-06876-08-640	Glass Filler Plug Button
12	16-16373-08-640	Drain Plug (Fountain Side)
12	10-26399-31-640	Drain Plug (Cooler Side) (included in item 15)
13	16-02705-08-640	Strainer Plate (included in item 15)
14	10-01471-40-560	Waste Gasket
15	60-27036-51-550	Precooler Assembly (includes items 12 & 13)
16	16-15286-51-550	Tailpiece
17	11-03462-20-550	Locknut
18	16-03463-08-640	Slip Nut
19	10-03529-40-560	Slip Nut Gasket
20	16-07470-51-550	Continuous Waste
21	40-14514-31-550	Precooler Baffle
22	60-15528-51-550	Evaporator Chiller
23	19-42339-51-550	Temperature Control
24	60-26793-51-550	Compressor Assembly
25a	19-26926-51-550	Relay/Overload Assembly (included in item 24)
26	10-10800-51-010	Drier
27	19-14761-51-550	Fan Motor
28	SEE FAN NOTE**	Fan Blade**
29	40-26720-43-730	Fan Bracket
30	40-14528-31-560	Shroud
31	19-15080-51-550	Condenser
32	10-14532-51-550	Valve Bracket
33	17-14037-42-590	Receptor (Fountain Side)
33	17-14548-42-590	Receptor (Cooler Side)
34	11-26275-43-890	Receptor Screws (4 each)
35	40-07475-43-730	Hanger Bracket (Fountain Side) (not shown)
35	40-06609-43-730	Hanger Bracket (Cooler Side) (not shown)
36	40-08104-43-XXX	Front Panel (Fountain Side) (not shown)
36	40-14322-43-XXX	Front Panel (Cooler Side) (not shown)
37	40-14710-43-XXX	Left Side Panel
38	40-14840-43-XXX	Right Side Panel
39	10-15431-51-550	Back Bumper
40	11-10083-43-XXX	Panel Screws (45 Cooler Side; 2 Fountain Side)
41	40-15077-43-730	Shelf
42	40-26030-43-730	Base
43	13-14905-31-920	Name Plate (not shown)
44	40-14748-43-730	Tie Bar
45	10-14551-31-550	Side Frames (2 each)
46	19-26779-51-550	Wiring Assembly

### ACCESSORIES AVAILABLE

Glass Fillers - See Spec Book

Glass Filler Installation Kit - 73-26285-51-550 (Does not include Glass Filler)

Vandal Proof Kit - 73-15243-51-550\*

Water Filtration Kit - 73-15242-51-550\* (mounts external to cooler)

XXX Please specify color when ordering. See Color Chart on page I-A for colors available.

\*See Detailed Parts Section for further breakdown.

\*\*FAN NOTE: If current fan blade screws on, use 10-42095-43-730. If not, use 10-42343-43-730.

# MODEL WM 14-3BL

MODEL#	MFG DATE S/N ENDING	COLD WATER CAP*	COMP H/P	VOLTAGE ± 10	PH	HZ	TOTAL AMPS	R-12 REFRIG CHARGE*	WATER INLET PSIG
WM14A-2BL	H8 - Current	14GPH	1/5	115	1	60	8.1	8.1	20-90

COOLER - HEIGHT: 28"	WIDTH: 18 1/8"	DEPTH: 14 1/4"
FOUNTAIN - HEIGHT: 16 1/8"	WIDTH: 15 7/8"	DEPTH: 14 1/4"

\*ARI ratings: capacity at GPH cooled to 50° with 90°F ambient temperature and 80°F inlet water.

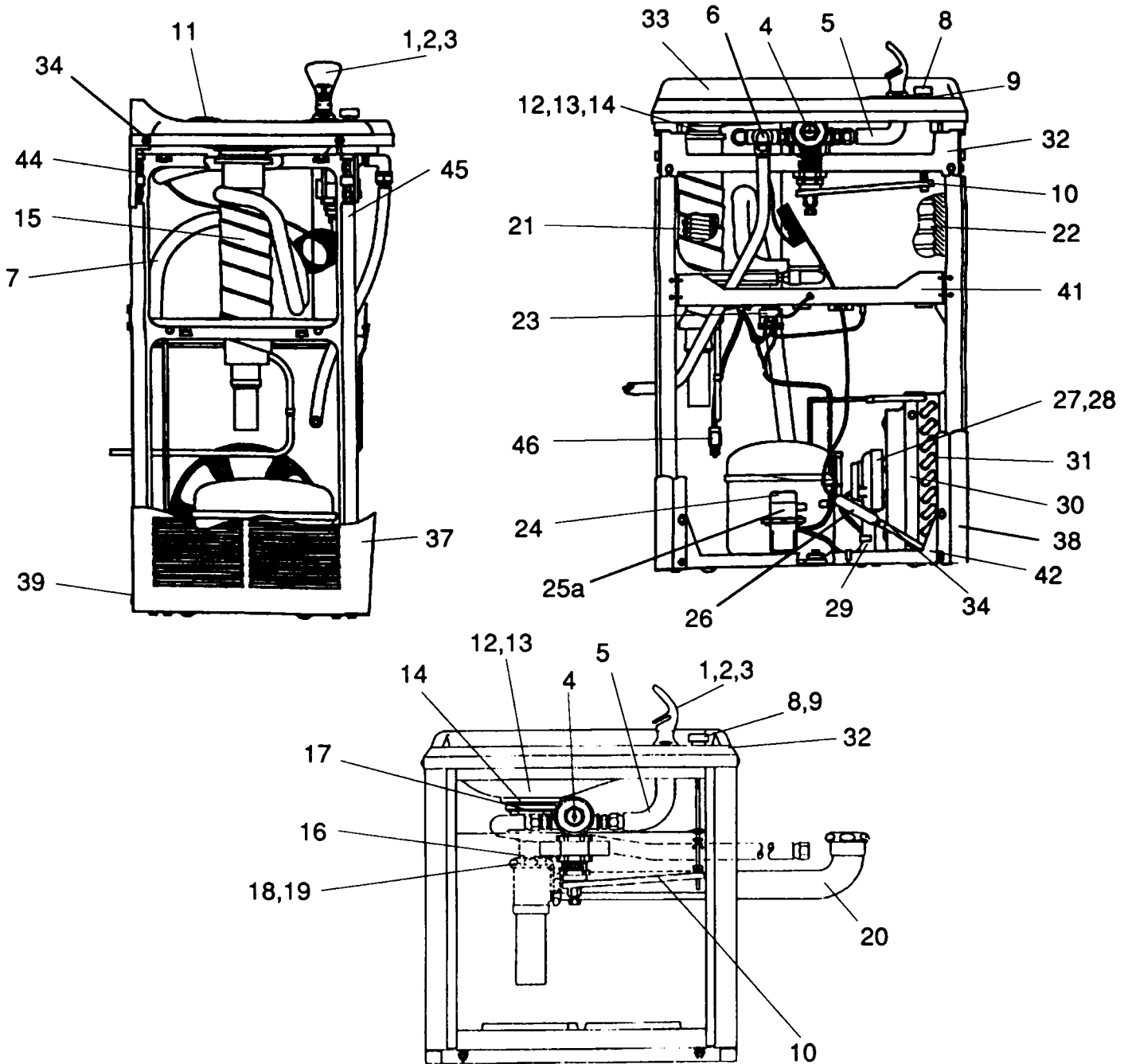

**To order parts, contact your nearest Halsey Taylor wholesaler or representative.**

*Continued product improvement makes specifications subject to change without notice.*

**Halsey Taylor.**