

# MODEL WM 16W

## WM 16W PART LIST

REF NO.	PART NUMBER	DESCRIPTION
1	16-03165-08-640	Projector
2	10-03227-40-560	Projector Gasket (2 each)
3	16-06092-08-550	Projector Nipple
4	60-06619-51-550	Valve Assembly *
4a	60-08050-51-550	Diaphragm Repair Kit* (for item 4)
5	60-14202-51-550	Stem Assembly*
6	60-06429-51-550	Push Button Stem Assembly*
6a	10-08137-31-870	Snap-In Bushing (included in item 6)
7	40-26741-43-730	Lever Arm
8	10-26399-31-640	Drain Plug
9	16-02705-08-640	Strainer Plate
10	10-01471-40-560	Waste Gasket
11	60-26892-51-550	Precooler Assembly
12	60-26893-51-550	Condenser Waste Assembly (for SN ending A89 and after)
12	60-07587-51-550	Condenser Waste Assembly (for SN ending M88 and before)
13	60-07746-51-550	Storage Tank
14	16-01453-08-550	Tank Plug (not shown)
15	19-42339-51-550	Primary Temperature Control (adjustable)
16	19-15342-51-550	Secondary Temperature Control (Non-adjustable)
17	60-08394-51-550	Compressor Assembly
17a	19-07765-51-550	Relay (included in item 17)
17b	19-07724-51-550	Overload (included in item 17)
17c	19-10858-82-550	Capacitor (included in item 17)
18	60-26557-51-550	Water Cooled Condenser (See Note Below)**
19	60-10108-51-550	Capillary Heat Exchanger
20	60-26556-51-550	Condenser Water Valve
21	17-07400-42-590	Receptor
22	11-07487-42-590	Receptor Screws (2 each)
23	11-07447-43-550	Receptor Speed Nut (2 each)
24	10-06876-08-640	Glass Filler Plug Button (not shown)
25	40-07446-43-XXX	Front Panel (not shown)
26	11-10083-43-890	Panel Screws (2 each)
27	13-14905-31-920	Name Plate (not shown)
28	40-06609-43-730	Hanger Bracket (not shown)
29	19-26675-51-550	Wiring Assembly

### ACCESSORIES AVAILABLE

Glass Fillers - See Spec Book  
 Glass Filler Installation Kit - 73-26285-51-550 (Does not include Glass Filler)  
 Vandal Proof Kit - 73-15243-51-640\*  
 Water Filtration Kit - 73-15242-51-550\* (mounts external to cooler)  
 73-15243-51-550\* (installs inside cooler)

**XXX Please specify color when ordering. See Color Chart on page I-A for colors available.**

**\*See Parts Section for further breakdown.**

**\*\* When replacing water cooled condenser, the condenser water valve must be replaced if it still has the Little Giant Valve installed.**

# MODEL WM 16W

MODEL#	MFG DATE S/N ENDING	COLD WATER CAP*	COMP H/P	VOLTAGE ± 10	PH	HZ	TOTAL AMPS	R-12 REFRIG CHARGE*	WATER INLET PSIG
WM16W	Current	16GPH	1/5	115	1	60	4.7	8.0	20-90

HEIGHT: 28"

WIDTH: 18 1/8"

DEPTH: 14 1/4"

\*ARI ratings: capacity at GPH cooled to 50° with 90°F ambient temperature and 80°F inlet water.

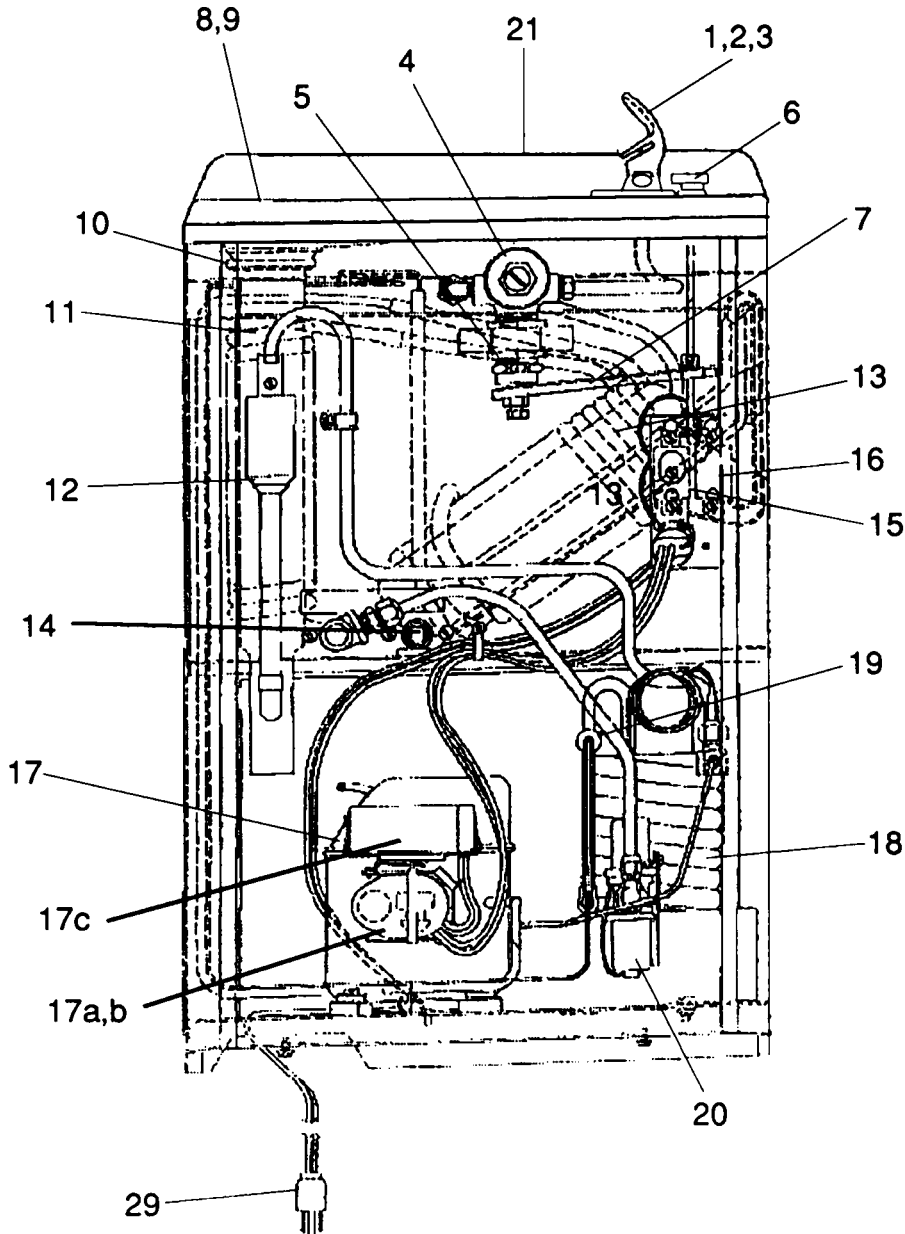

**To order parts, contact your nearest Halsey Taylor wholesaler or representative.**

*Continued product improvement makes specifications subject to change without notice.*

**Halsey Taylor.**