

MODELS WM 8A-1CB and 14A-1CB

WM 8A-1CB and 14A-1CB PART LIST

REF NO.	PART NUMBER	DESCRIPTION	WM 8A-1CB	WM 14A-1CB
1	10-14228-31-640	Projector	X	X
2	10-03227-40-560	Projector Gasket (2 each)	X	X
3	10-14224-51-550	Projector Nipple	X	X
4	60-14800-51-550	Regulator Assembly*	X	X
4a	60-14549-51-550	Valve Body Assembly (included in item 4)*	X	X
4b	60-08050-51-550	Diaphragm Repair Kit* (for item 4)	X	X
4c	60-14202-51-550	Valve Stem Assembly* (incl. in item 4)	X	X
5	60-14511-51-550	Push Button Stem Assembly*	X	X
6	10-14523-31-870	Stem Bushing	X	X
7	40-26741-43-730	Lever Arm for Push Button Assembly	X	X
8	16-14670-51-550	Hot Water Valve Assembly*	X	X
8A	10-06833-31-810	Handle (included in item 11)	X	X
8B	10-06832-08-640	Gooseneck (included in item 11)	X	X
8C	10-09673-51-550	Stem (included in item 11)	X	X
9	10-14532-51-550	Valve Bracket	X	X
10	10-26399-31-640	Drain Plug (included in item 13)	X	X
11	16-02705-08-640	Strainer Plate (included in item 13)	X	X
12	10-01471-40-560	Waste Gasket	X	X
13	60-27033-51-550	Precooler Assembly	X	X
14	10-14514-31-550	Precooler Baffle		X
15	60-14328-51-550	Evaporator Chiller	X	
15	60-15038-51-550	Evaporator Chiller		X
16	19-42339-51-550	Temperature Control	X	X
17	92522C	Hot Tank	X	X
18	19-15047-51-550	Hot Temperature Control	X	X
19	60-15572-51-550	Compressor Assembly	X	
19	60-15573-51-550	Compressor Assembly		X
19a	19-14891-51-550	Relay (included in item 19)	X	
19a	19-14062-51-550	Relay (included in item 19)		X
19b	19-14894-51-550	Overload (included in item 19)	X	
19b	19-14061-51-550	Overload (included in item 19)		X
20	19-14761-51-550	Fan Motor	X	X
21	19-42343-43-730	Fan Blade	X	X
22	40-26720-43-730	Fan Bracket	X	X
23	10-14528-43-730	Shroud	X	X
24	19-15079-51-550	Condenser	X	X
25	10-10800-51-010	Drier	X	X
26	60-15271-51-550	Air Gap Cup Assembly	X	X
27	29-14356-16-550	Capillary Tube	X	
27	29-14371-16-550	Capillary Tube		X
28	16-15464-08-550	Service Valve	X	X
29	19-26108-51-550	Wiring Assembly	X	X
30	19-26109-51-550	Thermal Link	X	X
31	40-14726-42-590	Receptor	X	X
32	11-26275-43-890	Receptor Screws (4 each)	X	X
33	40-14322-43-XXX	Front Panel (not shown)	X	X
34	40-14839-43-XXX	Left Side Panel (not shown)	X	X
35	40-14840-43-XXX	Right Side Panel (not shown)	X	X
36	11-10083-43-890	Panel Screws (49 each)	X	X
37	10-15431-51-550	Back Bumper	X	X
38	40-15077-43-730	Shelf	X	X
39	40-26030-43-730	Base	X	X
40	13-14905-31-920	Name Plate (not shown)	X	X
41	40-14748-43-730	Tie Bar	X	X
42	10-14551-31-550	Side Frames (2 each)	X	X
43	40-06609-43-730	Hanger Bracket	X	X

ACCESSORIES AVAILABLE

Vandal Proof Kit - 73-15243-51-550*

Water Filtration Kit - 73-15242-51-550 (mounts external to cooler)

XXX Please specify color when ordering. See Color Chart on page I-A for colors available.

*See Detailed Parts Section for further breakdown.

MODELS WM 8A-1CB and 14A-1CB

MODEL#	MFG DATE S/N ENDING	COLD WATER CAP*	COMP HP	VOLTAGE ± 10	PH	HZ	TOTAL AMPS	R-12 REFRIG CHARGE*	WATER INLET PSIG
WM8A-1CB	M8 - H7	8GPH	1/6	115	1	60	9.4	6.5 oz	20-90
WM14A-1CB	M8 - H7	14GPH	1/5	115	1	60	11.1	8.1 oz	20-90

HEIGHT: 31¼"

WIDTH: 18½"

DEPTH: 14¼"

*ARI ratings: capacity at GPH cooled to 50° with 90°F ambient temperature and 80°F inlet water

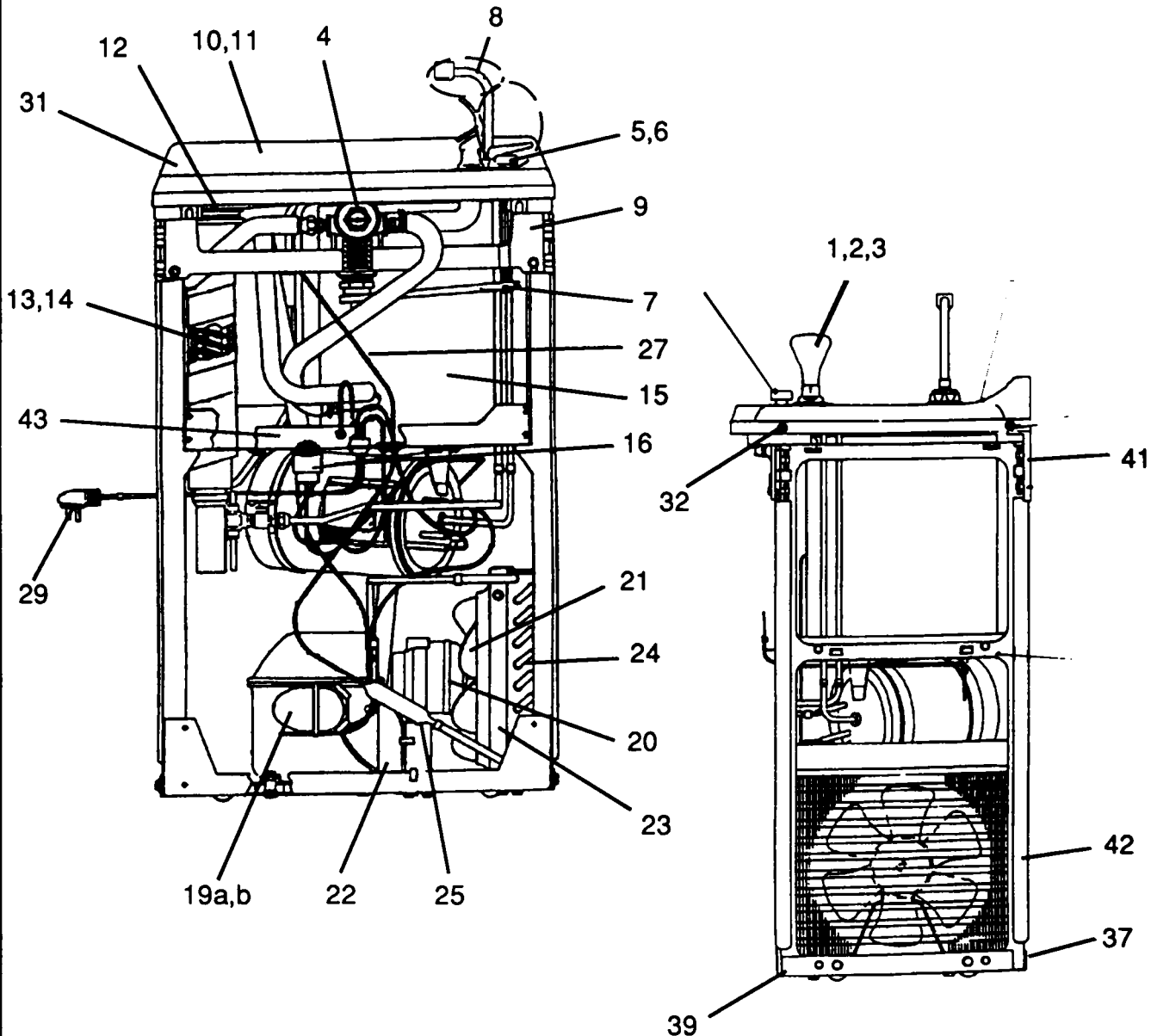

To order parts, contact your nearest Halsey Taylor wholesaler or representative.

Continued product improvement makes specifications subject to change without notice.

Halsey Taylor.